



Shire of Northam
Heritage, Commerce and Lifestyle

Shire of Northam

Agenda

Ordinary Council Meeting

20 December 2017



NOTICE PAPER

Ordinary Council Meeting

20th December 2017

President and Councillors

I inform you that an Ordinary Council meeting will be held in the Council Chambers, located at 395 Fitzgerald Street, Northam on 20th December 2017 at 5:30pm.

There will be a Forum meeting held in the Council Chambers on 13th December 2017 at 5:30 pm to discuss the contents of this agenda.

Yours faithfully



Jason Whiteaker
Chief Executive Officer



DISCLAIMER

This agenda has yet to be dealt with by the Council. The Recommendations shown at the foot of each item have yet to be considered by the Council and are not to be interpreted as being the position of the Council. The minutes of the meeting held to discuss this agenda should be read to ascertain the decision of the Council.

In certain circumstances members of the public are not entitled to inspect material, which in the opinion of the Chief Executive Officer is confidential, and relates to a meeting or a part of a meeting that is likely to be closed to members of the public.

No responsibility whatsoever is implied or accepted by the Shire of Northam for any act, omission, statement or intimation occurring during Council or Committee meetings.

The Shire of Northam disclaims any liability for any loss whatsoever and howsoever caused arising out of reliance by any person or legal entity on any such act, omission or statement of intimation occurring during Council or Committee meetings.

Any person or legal entity who acts or fails to act in reliance upon any statement, act or omission made in a Council or Committee meeting does so at that person's or legal entity's own risk.

In particular and without derogating in any way from the broad disclaimer above, in any discussion regarding any planning application or application for a licence, any statement or intimation of approval made by any member or Officer of the Shire of Northam during the course of any meeting is not intended to be and is not taken as notice of approval from the Shire of Northam.

The Shire of Northam advises that anyone who has any application lodged with the Shire of Northam must obtain and should only rely on WRITTEN CONFIRMATION of the outcome of the application and any conditions attaching to the decision made by the Shire of Northam in respect of the application.

The Shire of Northam advises that any plans or documents contained within this agenda may be subject to copyright law provisions (*Copyright Act 1968*, as amended) and that the express permission of the copyright owner(s) should be sought prior to their reproduction. It should be noted that copyright owners are entitled to take legal action against any persons who infringe their copyright. A reproduction of material that is protected by copyright may represent a copyright infringement.

Contents

1.	DECLARATION OF OPENING.....	7
2.	ATTENDANCE.....	7
2.1	APOLOGIES.....	7
2.2	APPROVED LEAVE OF ABSENCE	7
3.	DISCLOSURE OF INTERESTS.....	7
4.	ANNOUNCEMENT BY THE PRESIDING MEMBER (WITHOUT DISCUSSION)	8
5.	PUBLIC QUESTION/STATEMENT TIME	10
5.1	PUBLIC QUESTIONS.....	10
5.2	PUBLIC STATEMENTS.....	10
6.	RESPONSE TO PREVIOUS PUBLIC QUESTIONS TAKEN ON NOTICE	10
7.	RECEIVING OF PETITIONS, PRESENTATIONS AND DEPUTATIONS	10
7.1	PETITIONS.....	10
7.2	PRESENTATIONS.....	10
7.3	DEPUTATIONS.....	10
8.	APPLICATION FOR LEAVE OF ABSENCE.....	11
9.	CONFIRMATION OF MINUTES	11
9.1	ORDINARY COUNCIL MEETING HELD 15 TH NOVEMBER 2017	11
9.2	NOTES FROM THE COUNCIL FORUM MEETING HELD 13 TH DECEMBER 2017	11
9.2	NOTES FROM THE STRATEGIC COUNCIL MEETING HELD 22 ND NOVEMBER 2017	11
10.	ITEMS BROUGHT FORWARD FOR THE CONVENIENCE OF THOSE IN THE PUBLIC GALLERY	11
11.	REPORTS OF COMMITTEE MEETINGS	12
11.1	BUSH FIRE ADVISORY COMMITTEE MEETING HELD ON 14 TH NOVEMBER 2017 12	
12.	OFFICER REPORTS	93
12.1	CEO'S Office	93
12.1.1	Policy for Information and Communication Technology (ICT) Use – Elected Members.....	93
12.2	ENGINEERING SERVICES.....	101
12.3	DEVELOPMENT SERVICES	102

12.3.1	Mid-West Wheatbelt (Central) Joint Development Assessment Panel (Wheatbelt Joint DAP) - Local Government Nominations	102
12.3.2	Application for Development Approval – Northam Youth Space - Northam Recreation Precinct, Northam	106
12.3.3	Request to Vary Local Planning Policy 23 – Lot 125 Wilson Street, Grass Valley	168
12.3.4	Pedestrian Access Way – Adjacent to 16 Brown Road and 51 Olive Road, Wundowie	181
12.3.5	Application for Development Approval - Proposed Rural Pursuit (Growing Advanced Trees) at 19 Brown Road, Wundowie	188
12.3.6	Application for retrospective development approval for earthworks associated with a man-made dam at Lot 237 Brockman Street, Bakers Hill.....	196
12.4	CORPORATE SERVICES.....	215
12.4.1	Accounts & Statements of Accounts - November 2017 ...	215
12.4.2	Financial Statements for the Period Ending 31 st October 2017	283
12.4.3	Operation of Waste Disposal Facilities Local Law 2008	302
12.4.4	Parking and Parking Facilities Amendment Local Law 2017 307	
12.4.5	Standing Orders Repeal Local Law 2017	337
12.4.6	Write off Rates Debt for Hangar 8, Northam Airport.....	379
12.4.7	Change of Ownership for Hangar 31, Northam Airport....	382
12.4.8	Aboriginal Environmental and Interpretative Centre Solar System	385
12.5	COMMUNITY SERVICES	389
12.5.1	Application for Fee Waiver - Pipeline Challenge.....	389
12.5.2	Application for Fee Reduction – Northam PCYC.....	393
12.5.3	Naming of Aboriginal & Environmental Interpretive Centre 399	
12.5.4	Tender 5 of 2017 – Architectural/Building Design Services for the Northam Aquatic Centre.....	401
13.	MATTERS BEHIND CLOSED DOORS	406
13.2	CHIEF EXECUTIVE OFFICER REVIEW COMMITTEE MEETING HELD ON 30 TH NOVEMBER 2017	406
14.	MOTIONS OF WHICH PREVIOUS NOTICE HAS BEEN GIVEN	406

15. URGENT BUSINESS APPROVED BY PERSON PRESIDING OR BY DECISION406

16. DECLARATION OF CLOSURE406



1. DECLARATION OF OPENING

2. ATTENDANCE

Council:

Shire President
Deputy President
Councillors

C R Antonio
M P Ryan
C L Davidson
J E Williams
R W Tinetti
S B Pollard
A J Mencshelyi
T M Little
J Proud
C P Della

Staff:

Chief Executive Officer
Executive Manager Engineering Services
Executive Manager Development Services
Executive Manager Community Services
Executive Manager Corporate Services
Executive Assistant – CEO

J B Whiteaker
C D Kleynhans
C B Hunt
R Rayson
C Young
A C Maxwell

2.1 APOLOGIES

Nil.

2.2 APPROVED LEAVE OF ABSENCE

Nil.

3. DISCLOSURE OF INTERESTS

Item Name	Item No.	Name	Type of Interest	Nature of Interest



4. ANNOUNCEMENT BY THE PRESIDING MEMBER (WITHOUT DISCUSSION)

<u>Visitations and Consultations</u>	
20/11/17	Mayors, Shire President and Deputy Training - Perth
21/11/17	Launch of Emerging Leaders in Agriculture – Muresk Campus
22/11/17	Best and Less Store Official Opening
22/11/17	District Health Advisory Council Meeting – Northam
23/11/17	WALGA Avon Midland Zone Meeting - Toodyay
23/11/17	WALGA Local Government Workshop - Toodyay
25/11/17	New Shopping Centre – Coles Official Opening - Northam
25/11/17	Northam Police Station Public Open Day
29/11/17	Wundowie Community Meeting
04/12/17	AROC Meeting - Toodyay
05/12/17	International Volunteer Day event - Northam
06/12/17	RCAWA Meeting
07/12/17	LEMC Meeting - Northam
07/12/17	Northam Chamber of Commerce AGM
07/12/17	West Northam Primary School Presentation and Graduation
08/12/17	Christmas on Fitzgerald's - Northam
09/12/17	SES Awards
09/12/17	Bakers Hill Christmas Fair
11/12/17	Bakers Hill Riding for the Disabled Driving Centre Lunch
12/12/17	Avonvale School Awards
13/12/17	Silver Wings Community Christmas Lunch
14/12/17	Avonvale Education Support Centre Presentations
16/12/17	Southern Brook Christmas Tree
<u>Upcoming Events</u>	
25/12/17	Christmas Day
26/12/17	Boxing Day
31/12/17	New Year's Eve
01/01/18	New Year's Day

Operational Matters:

Be Safe over the Festive Season

With the Christmas and New Year season approaching, all employers and employees need to take care and be safe. Enjoy yourselves, but be safe, and make sure you have an appointed "Skipper". We want to see everyone safe into the New Year.



Council Meeting Dates 2018

Council Meeting Dates have been set for 2018. A change in some meeting locations will occur. IN addition to the Shire of Northam Chambers, meetings will also be held at Bakers Hill, Wundowie and Grass Valley.

2016 / 2017 Annual Electors Meeting

Council voted to hold the annual electors meeting on the 13th December 2017. This forms part of the Community / Corporate Business Plan and allows two-way communication between the Shire of Northam and stakeholders.

Strategic Matters:

Local Laws

The Shire of Northam continues to review local laws. Currently, the Standing Orders Local Law and Dogs Amendment Local Law 2017 are under review.

Small Business Friendly Local Government initiative

The Shire of Northam continues to look at ways to improve interactions with small business. As part of this, the Shire of Northam has recently signed the Small Business Friendly Local Government Charter. Part of this charter, along with other initiatives, is, ensuring prompt payment of small business invoices and understanding how small businesses operate, including their goals and key challenges.

Major Projects

There are a number of major projects currently under construction in Northam, with some looking to be completed during 2018.

These include, but are not limited to: The Aboriginal and Environmental Interpretive Centre, New Brand Development for Northam Shire, the new Swimming Pool and precinct and the new Youth Space.

5. PUBLIC QUESTION/STATEMENT TIME

5.1 PUBLIC QUESTIONS

5.2 PUBLIC STATEMENTS

6. RESPONSE TO PREVIOUS PUBLIC QUESTIONS TAKEN ON NOTICE

Ordinary Council Meeting 15th November 2017

The following response was provided to Amanda Abbott from Northam Scouts in writing on 27th November 2017:

I refer to your question which was taken on notice at the Ordinary Council meeting held on 15th November 2017 and wish to offer the following response:

It is currently difficult for Officer's to identify one facility that has access to all of the requirements in the one place, without knowing these exact requirements (numbers of participants, how often the group meets, how many times they need to access storage for larger equipment etc). Access to facilities for meetings and indoor activities is available at some Shire venues, with access to storage for larger items accessible from another site. There is not one Shire facility that has access to all of the requirements.

As stated at the meeting, Mr Ross Rayson, Executive Manager Community Services is happy to discuss the Northam Scouts exact requirements to allow us to then ascertain some options. Should you wish to discuss this matter further, please contact Mr Rayson on (08) 9622 6100 or by email at records@northam.wa.gov.au.

7. RECEIVING OF PETITIONS, PRESENTATIONS AND DEPUTATIONS

7.1 PETITIONS

Nil.

7.2 PRESENTATIONS

Nil.

7.3 DEPUTATIONS

Nil.

8. APPLICATION FOR LEAVE OF ABSENCE

Nil.

9. CONFIRMATION OF MINUTES

9.1 ORDINARY COUNCIL MEETING HELD 15TH NOVEMBER 2017

RECOMMENDATION

That the minutes of the Ordinary Council meeting held on Wednesday, 15th November 2017 be confirmed as a true and correct record of that meeting.

9.2 NOTES FROM THE COUNCIL FORUM MEETING HELD 13TH DECEMBER 2017

RECOMMENDATION

That Council receive the notes from the Council Forum meeting held Wednesday, 13th December 2017.

9.2 NOTES FROM THE STRATEGIC COUNCIL MEETING HELD 22ND NOVEMBER 2017

RECOMMENDATION

That Council receive the notes from the Strategic Council meeting held on Wednesday, 22nd November 2017.

10. ITEMS BROUGHT FORWARD FOR THE CONVENIENCE OF THOSE IN THE PUBLIC GALLERY

11. REPORTS OF COMMITTEE MEETINGS

11.1 BUSH FIRE ADVISORY COMMITTEE MEETING HELD ON 14TH NOVEMBER 2017

Receipt of Minutes:

RECOMMENDATION

That Council receive the minutes from the Bush Fire Advisory Committee meeting held on 14th November 2017.

Adoption of Recommendations:

RECOMMENDATION

That Council:

1. Note the Community Emergency Services Manager Report as provided.
2. Allow permits to burn to be issued on any day of the week including Sundays.
3. Request the Department of Fire and Emergency Services (DFES) to **review the Shire of Northam's Risk to Resource Plan**, in liaison with the Shire of Northam.
4. Request that at the completion of the Risk to Resource Plan review the draft document be presented to a Bush Fire Advisory Committee and subsequently Council meeting for endorsement.
5. Request the Department of Fire & Emergency Services (DFES) for the provision of a representative to assist the Brigades in liaising with the community to raise awareness about volunteers/bushfire safety and new recruits.
6. Send a letter to the Department of Fire and Emergency Services (DFES) raising the following concerns with the DFES Crew Protection System upgrade:
 - No muffler on Diesel Pump with high noise levels;
 - No Pump controls on the rear pump panel; and
 - Plumbing work and allowances for pump movement.
7. Recommend brigades to display their members training records on a graph board at each of their stations; and
8. Consult with the Bush Fire Advisory Committee (BFAC) prior to a Council decision for any changes being made to the BFAC Terms of Reference.

Attachment 1



Shire of Northam
Heritage, Commerce and Lifestyle

Shire of Northam

Minutes

Bush Fire Advisory Committee

14 November 2017

Bush Fire Advisory Committee Meeting Minutes
14 November 2017



DISCLAIMER

This agenda has yet to be dealt with by the Council. The Recommendations shown at the foot of each item have yet to be considered by the Council and are not to be interpreted as being the position of the Council. The minutes of the meeting held to discuss this agenda should be read to ascertain the decision of the Council.

In certain circumstances members of the public are not entitled to inspect material, which in the opinion of the Chief Executive Officer is confidential, and relates to a meeting or a part of a meeting that is likely to be closed to members of the public.

No responsibility whatsoever is implied or accepted by the Shire of Northam for any act, omission, statement or intimation occurring during Council or Committee meetings.

The Shire of Northam disclaims any liability for any loss whatsoever and howsoever caused arising out of reliance by any person or legal entity on any such act, omission or statement of intimation occurring during Council or Committee meetings.

Any person or legal entity who acts or fails to act in reliance upon any statement, act or omission made in a Council or Committee meeting does so at that person's or legal entity's own risk.

In particular and without derogating in any way from the broad disclaimer above, in any discussion regarding any planning application or application for a licence, any statement or intimation of approval made by any member or Officer of the Shire of Northam during the course of any meeting is not intended to be and is not taken as notice of approval from the Shire of Northam.

The Shire of Northam advises that anyone who has any application lodged with the Shire of Northam must obtain and should only rely on WRITTEN CONFIRMATION of the outcome of the application and any conditions attaching to the decision made by the Shire of Northam in respect of the application.

The Shire of Northam advises that any plans or documents contained within this agenda may be subject to copyright law provisions (*Copyright Act 1968*, as amended) and that the express permission of the copyright owner(s) should be sought prior to their reproduction. It should be noted that copyright owners are entitled to take legal action against any persons who infringe their copyright. A reproduction of material that is protected by copyright may represent a copyright infringement.

Bush Fire Advisory Committee Meeting Minutes
14 November 2017



Contents

1.	DECLARATION OF OPENING.....	4
4.	ELECTION OF PRESIDING MEMBER	4
2.	ATTENDANCE.....	4
	2.1 APOLOGIES.....	5
3.	DISCLOSURE OF INTERESTS.....	6
5.	CONFIRMATION OF MINUTES	6
	5.1 COMMITTEE MEETING HELD 20 JUNE 2017.....	6
6.	COMMITTEE REPORTS	7
	6.1 CHIEF BUSHFIRE CONTROL OFFICER (CBFCO) REPORT.....	7
	6.2 COMMUNITY EMERGENCY SERVICES MANAGER REPORT	9
	6.3 ALLOW PERMITS TO BURN ON SUNDAYS.....	15
	6.4 RISK TO RESOURCE.....	18
7.	MOTIONS OF WHICH PREVIOUS NOTICE HAS BEEN GIVEN.....	76
	7.1 CLACKLINE BFB.....	76
	7.1.1 Loss of Experience FCO's	76
	7.1.2 Membership Issues	76
	7.2 BAKERS HILL BFB.....	78
	7.3 GRASS VALLEY BFB.....	78
	7.3.2 Brigade Training Records	78
8.	URGENT BUSINESS APPROVED BY PERSON PRESIDING OR BY DECISION .	79
	7.1 CHANGES TO THE BFAC TERMS OF REFERENCE.....	79
9.	DATE OF NEXT MEETING	80
10.	DECLARATION OF CLOSURE	80

Bush Fire Advisory Committee Meeting Minutes
14 November 2017



1. DECLARATION OF OPENING

The Chief Executive Officer, Mr J Whiteaker declared the meeting open at 5:42pm.

Mr Whiteaker advised that the first item of business would be to elect the Chairperson for the ensuing two year period and item 4 – Election of Presiding Member would be brought forward.

4. ELECTION OF PRESIDING MEMBER

In accordance with section 5.12 of the Local Government Act 1995. The members of a committee are to elect a presiding member from amongst themselves in accordance with Schedule 2.3, Division 1.

The members of a committee may elect a deputy presiding member from amongst themselves but any such election is to be in accordance with Schedule 2.3, Division 2.

Should the presiding member not be available or is unable or unwilling to perform the functions of presiding member, then the deputy presiding member, if any, may perform the functions of presiding member.

The Chief Executive Officer called for nominations. One nomination was received in writing from Cr Terry Little. The Chief Executive Officer called for further nominations. As there were no further nominations, the Chief Executive Officer declared Cr Terry Little the Chairperson of the Bushfire Advisory Committee for the ensuing two year period (November 2017 – October 2019).

Cr Little took the Chair and thanked all for attending.

2. ATTENDANCE

Voting Committee:

Councillor – Shire of Northam
Councillor – Shire of Northam
Chief Bush Fire Control Officer

Inkpen Brigade
Clackline Muresk Brigade
Bakers Hill Brigade
Grass Valley Brigade

Terry Little
Carl Della
Mathew Macqueen at
5:44pm
Murray Bow
Blair Wilding at 6:15pm.
Steve Gray
Sam Moss

Bush Fire Advisory Committee Meeting Minutes
14 November 2017



Irishtown Brigade	Murray McGregor at 5:46pm.
Jennapullin Brigade	Aaron Smith
Southern Brook Brigade	Paul Antonio
Northam Volunteer Fire and Rescue Service	Greg Montgomery

Representatives and Staff:

Chief Executive Officer	Jason Whiteaker
Executive Manager Development Services	Chadd Hunt
Community Emergency Service Manager	Daniel Hendriksen
Executive Assistant – Chief Executive Officer	Alysha Maxwell
Department of Fire and Emergency Service	Sven Anderson
Department of Parks and Wildlife (Wheatbelt)	Graeme Keals
Department of Parks and Wildlife (Perth Hills)	Michael Pasotti

Gallery:

Bakers Hill Bushfire Brigade	Mark Bowring
	Kris Brown
Clackline Bushfire Brigade	Matt Letch
Grass Valley Bushfire Brigade	Phil Gentle
Irishtown Bushfire Brigade	Rob Herzer

2.1 APOLOGIES

Deputy Bush Fire Control Officer	Simon Peters
Wundowie Volunteer Fire and Rescue Service	Trevor Sangston

Bush Fire Advisory Committee Meeting Minutes
14 November 2017



3. DISCLOSURE OF INTERESTS

Nil.

The Chief Executive Officer explained the types of interests (impartiality, proximity, financial and indirect financial) and when these are required to be declared including when members are required to leave the meeting.

Clarification was sought in relation to matters which affect the majority of the committee. Mr Whiteaker explained that there are exemptions for when there are 'interests in common' in addition, the Minister for Local Government can grant exemptions.

Murray McGregor entered the meeting at 5:46pm.

5. CONFIRMATION OF MINUTES

5.1 COMMITTEE MEETING HELD 20 JUNE 2017

RECOMMENDATION / COMMITTEE DECISION

Minute No: BFAC.165

Moved: Murray McGregor

Seconded: Murray Bow

That the minutes of the Bush Fire Advisory meeting held 20th June 2017 be confirmed as a true and correct record of that meeting.

CARRIED 10/0

Bush Fire Advisory Committee Meeting Minutes
14 November 2017



6. COMMITTEE REPORTS

6.1 CHIEF BUSHFIRE CONTROL OFFICER (CBFCO) REPORT

Address:	N/A
Owner:	N/A
File Reference:	5.1.3.1
Reporting Officer:	Mathew Macqueen CBFCO
Responsible Officer:	Chadd Hunt Executive Manager Development Services
Voting Requirement	Simple Majority

BRIEF

The Chief Bushfire Control Officer Report will be provided at the meeting.

ATTACHMENTS

Nil.

BACKGROUND / DETAILS

CONSIDERATIONS

Strategic Community / Corporate Business Plan

Objective: Provide services and processes to enhance public safety.

Strategy C2.3: Provide, monitor and improve adequate Bush Fire Protection provisions.

Action: Support local bushfire brigades in bushfire management.

Financial / Resource Implications

Nil.

Legislative Compliance

Nil.

Policy Implications

Nil.

Stake Holder Engagement / Consultation

Nil.

Risk Implications

Bush Fire Advisory Committee Meeting Minutes
14 November 2017



Nil.

OFFICER'S COMMENT

Items to be discussed include:

- Fires since previous meeting;
- Operational items;
- Safety Circulars;
- RUI exercise; and
- Radio Procedures and etiquette.

RECOMMENDATION

That Council note the Chief Bushfire Control Officer Report as provided.

Mr Macqueen advised that there were no matters to report on and a report will be provided at the conclusion of the bushfire season.

Bush Fire Advisory Committee Meeting Minutes
14 November 2017



6.2 COMMUNITY EMERGENCY SERVICES MANAGER REPORT

Address:	N/A
Owner:	N/A
File Reference:	5.1.3.1
Reporting Officer:	Daniel Hendriksen Community Emergency Services Manager
Responsible Officer:	Chadd Hunt Executive Manager Development Services
Voting Requirement	Simple Majority

BRIEF

For the Committee to receive and note the update provided by the Community Emergency Services Manager.

ATTACHMENTS

Attachment 1: Progress against Outstanding BFAC / Council decisions.

BACKGROUND / DETAILS

N/A.

CONSIDERATIONS

Strategic Community / Corporate Business Plan

Objective: Provide services and processes to enhance public safety.

Strategy C2.3: Provide, monitor and improve adequate Bush Fire Protection provisions.

Action: Support local bushfire brigades in bushfire management.

Financial / Resource Implications

Nil.

Legislative Compliance

Nil.

Policy Implications

Nil.

Stake Holder Engagement / Consultation

Nil.

Bush Fire Advisory Committee Meeting Minutes
14 November 2017



Risk Implications

Nil.

OFFICER'S COMMENT

Appliance Servicing

A reminder to all brigades to book in appliances with Host Autos for their pre-season service. Please mark on the windscreen with whiteboard marker any concerns or broken items.

Grass Valley and Bakers Hill Sheds

Grass Valley BFB have approved the final plan for the shed extension, in the next month I will complete the specifications for brigade approval. Once the site has been confirmed and the specification finalised the next stage of the process is to submit an agenda item to council to approve the budget for the shed, the plans can then be submitted to the architect and tender advertised for the construction.

Bakers Hill BFB have 4 possible sites if it is decided to relocate the shed. The first at the original site, at the BMX track, NE corner of Hooper Park and the Recreation Centre. This will need to go to the progress association and council then to DFES to see if we can build a new shed over extending the existing. The issue with the current site is that it does not allow for parking or any further future growth and with the Bakers Hill area expanding it is foreseen that at some point we would require a third and even a fourth appliance.

Personal Protective Equipment (PPE)

2017 Preseason PPE order is due to be delivered by the end of November. There was a hold up with a container with the jackets it should be off the boat on the 14th Nov. No further orders will be made until April 2018.

Bushfire Manual

The CBFCO and I have begun creating the Bushfire Manual. The Manual will contain the Bushfire Management Plan, Legislation, Procedures and Brigade Administration. It will also include all decisions from BFAC and Council in one handy document. Once completed it will be handed out to new members and brigades to assist them out in the field if they are unsure on the procedure. In the coming months the completed Draft will be sent out to brigades for comment.

WAERN 400MHz upgrade

All WAERN radios on the Northam Network will be receiving the 400Mhz upgrade in the next few weeks. I will be in contact with all FCO's to organise an appointment to get the upgrade.

Bush Fire Advisory Committee Meeting Minutes
14 November 2017



RECOMMENDATION / COMMITTEE DECISION

Minute No: BFAC.166

Moved: Murray McGregor

Seconded: Sam Moss

That Council note the Community Emergency Services Manager Report as provided.

CARRIED 10/0

Mr Hendriksen discussed the items reported as listed under the 'Officer's Comment' section of the report.

Questions were asked in relation to the following matters:

- WA Emergency Radio Network (WAERN) – it was queried whether Brigades will be contacted to take their vehicles for upgrades. Mr Hendriksen confirmed that he will be contacting brigades to do this.
- Bakers Hill Shed – the timeframe for this was queried. Mr Hendriksen advised that DFES recommend that this be completed in one year however local governments quite often seek an extension. As the location for the shed is to be confirmed (i.e. existing location or an alternative) it is expected that the process will be protracted but is expected that significant inroads toward the completion would have been made.
- PPE – it was queried what condition/levels are for current PPE. Mr Hendriksen advised that the condition and stock levels for PPE have significantly improved over the past 3 years as this has slowly been built up. Inkpen and Southern Brook's PPE were kitted out last year and Grass Valley will be done this year. Bakers Hill and Clackline's PPE has always been in relatively good condition. Upgrades have included replacing helmets, we will then be looking to provide boots and upgrade the respirators.

Bush Fire Advisory Committee Meeting Minutes
14 November 2017



Attachment 1

Date	Motion No	Item No	Subject	Motion	Action By	Comment	Date Completed	Status
2/11/2016	C.2854	9.1	Bushfire Advisory Committee (BFAC) - 25 October 2016	BFAC recommends to Council that: - The Shire undertakes an immediate risk assessment by a competent person(s) into the readiness of BFB's to respond to structure and car fires in the Shire.	CESM	15/11/16 EMDS discussing with LGIS if they could undertake the risk assessment-23/11/16 LGIS referred the matter to Graham Swift at DFES to assist. 07-02-17 - Emailed DFES regarding undertaking the Risk Assessment on behalf of the Shire. 17/03/2017 - DFES are undertaking the Risk Assessment which will be provided as soon as possible. Some instruction manuals have been provided. 14/07/2017 - Still waiting for Assessment to be completed by DFES. No change.		Open
19/07/2017	C.3083	11.1	BUSH FIRE ADVISORY COMMITTEE MEETING HELD ON 20 JUNE 2017	That Council: 1. Note the Community Emergency Services Manager Report as provided; 2. Appoints the following Fire Control Officers for the 2017/18 Season subject to the individual complying with the adopted minimum training and experience standards: Bakers Hill - Ulo Rumjantsev - Simon Peters - Kirstler Brown - Suzanne Brown - Gordon Ashman (Weather Officer only) Clackline / Muresk - Matthew Macqueen - Matthew Letch (Permit Only until training requirement met) - Blair Wilding (Permit Only until training requirement met) - Nick Tighe (Permit Only until training requirement met) Grass Valley - Phillip Lloyd - Paul Reynolds (Permit Only until training requirement met) - Phil Gentle (Weather Officer only)	CESM	08/09/2017 - 1. Complete no action. 2. Complete - Certificates and acknowledgement letter set to FCO's New list created and added to website. 3. Complete - Certificates and acknowledgement letter set to Chief and Deputy. New list created and added to website. 4. Complete - Letter sent to FES Commissioner advising of the creation of the brigade. No acknowledgement received. 6. As we have not received acknowledgement from DFES no advertising has been done 7. Not started. 8. Not started. 9. Not started. 10. Completed - Firebreak notice printed and sent out with rates to residents.		Open

Bush Fire Advisory Committee Meeting Minutes
14 November 2017



Date	Motion No	Item No	Subject	Motion	Action By	Comment	Date Completed	Status
				<p>Inkpen</p> <ul style="list-style-type: none"> - Sim Kuiper (Weather & Permit Only until training requirement met) - Clive Owen (Permit Only until training requirement met) - Nic Dewar <p>Irishtown</p> <ul style="list-style-type: none"> - Rob Herzer <p>Southern Brook</p> <ul style="list-style-type: none"> - Paul Antonio (Permit Only until training requirement met) <p>Norlham</p> <ul style="list-style-type: none"> - Greg Montgomery - Daniel Hendriksen <p>Wundowie</p> <ul style="list-style-type: none"> - Iyron McMahon <p>Jennapullin</p> <ul style="list-style-type: none"> - Aaron Smith (Weather Officer only) <p>3. Appoint Mr Mathew Macqueen as the Chief Bushfire Control Officer and Mr Simon Peters as the Deputy Chief Bushfire Control Officer for the 2017/18 period;</p> <p>4. Create the Wundowie Bushfire Brigade under Section 41 Bushfire Act 1954;</p> <p>5. Create and discuss a draft memorandum of understanding with Wundowie FRS and DFES to utilise their facilities and members in Wundowie;</p> <p>6. Advertise the proposed intention to create a joint Wundowie BFB/VFRS Brigade to attract new membership of volunteers;</p> <p>7. Submit a business case to DFES to fund the Wundowie joint brigade out of the ESL and supply vehicles suitable for the area (Possibly a 3.4U and LT) make the necessary adjustments to the current building; and</p> <p>8. Create a specific fire district for Wundowie BFB to include the land east of Linley Valley Road, west of Coates and Sims</p>				

Bush Fire Advisory Committee Meeting Minutes
14 November 2017



Date	Motion No	Item No	Subject	Motion	Action By	Comment	Date Completed	Status
				road, and everything north of Great Eastern Highway. (See Map above). 9. Advertise the proposed Northam Central Bushfire Brigade seeking expression of interest in the Northam locality and present the findings to a Bushfire Advisory Committee Meeting; 10. Endorse the 2017/18 Fire Break Notice as previously adopted for the 2016/17 subject to the inclusion of: - Giving landowners of land greater than 1 hectare the options of either installing a firebreak, slashing the entire property or a combination of both; and - Minor streamlining changes to make the notice more readable for the general public. - An alteration to the restricted and prohibited burning period dates in section 9 of the Firebreak Notice to: - Restricted: 1st October to 30th November; o Prohibited: 1st December to 28th February; and - Restricted: 1st March to 30th April.				

UNCONFIRMED

Bush Fire Advisory Committee Meeting Minutes
14 November 2017



6.3 ALLOW PERMITS TO BURN ON SUNDAYS

Address:	N/A
Owner:	N/A
File Reference:	5.1.3.1
Reporting Officer:	Daniel Hendriksen Community Emergency Services Manager
Responsible Officer:	Chadd Hunt Executive Manager Development Services
Voting Requirement	Simple Majority

BRIEF

For Council to consider allowing burning permits to be issued on Sundays.

ATTACHMENTS

Nil.

BACKGROUND / DETAILS

Historically The Shire of Northam has not issued permits on Sundays. A number of brigades and members have raised the issue of whether burning with a permit on Sundays should be permitted.

With most residents working Monday to Friday many residents can only have the time to burn on the weekends. It is important that we can give them the time to prepare their properties. On most weekends there is many more brigade members around to deal with an incident should one occur where on a week day we struggle to crew vehicles.

CONSIDERATIONS

Strategic Community / Corporate Business Plan

Theme Area 5: Infrastructure & Service Delivery

Outcome 5.2: Environmental risks are proactively managed to minimise impact on residents.

- Continued bushfire management planning and mitigation works; and
- Proactive weed and pest management.

Financial / Resource Implications

Nil.

Bush Fire Advisory Committee Meeting Minutes
14 November 2017



Legislative Compliance

Section 18 (10A) the *Bushfires Act 1954* which states:

(10A) Subject to the regulations a local government may by resolution declare that within its district bush may be burnt only on such dates and by such persons as are prescribed by a schedule of burning times adopted by the local government.

Historically the Shire of Northam has not allowed burning on Sundays. Officers were unable to find any shire policies or BFAC minutes to support this position. This condition is usually published in the Government Gazette as part of the Fire Break notice. In the past 4 years the Shire of Northam have not gazetted in the firebreak notice that permits will not be issued on Sundays. As it is not stipulated in the notice a decision by Council would allow FCO's to issue permits on Sundays.

Policy Implications

Nil.

Stakeholder Engagement / Consultation

Nil.

Risk Implications

By allowing burning on Sundays it will assist in minimising bushfire risks in the district.

OFFICER'S COMMENT

It is the Officer's recommendation, along with two or more brigades that the "No Burning on Sunday's" condition should be revoked to allow residences to prepare their property by reducing the fuel loads.

RECOMMENDATION / COMMITTEE DECISION

Minute No: BFAC.167

Moved: Murray McGregor

Seconded: Steve Gray

That Council allow permits to burn to be issued on any day of the week including Sundays.

CARRIED 9/1

Bush Fire Advisory Committee Meeting Minutes
14 November 2017



- It was queried whether it is illegal to burn on Sundays. The Chief Executive Officer advised that it is not 'illegal' however Council does not support this from a policy position.
- Discussion was held around this already occurring.
- Debate was held around the motion:
 - Arguments for the motion:
 - This is already occurring in some areas of the Shire and would ensure consistency and fairness across the community; and
 - This would provide convenience to residents, in particular those who work full time and are restricted to weekends to get their properties in order.
 - Arguments against the motion:
 - It was believed that this was not required and there are six other days that burning can be undertaken on.
 - The burden this would place on Brigades who may be required to police the burns.

Bush Fire Advisory Committee Meeting Minutes
14 November 2017



6.4 RISK TO RESOURCE

Address:	N/A
Owner:	N/A
File Reference:	5.1.3.1
Reporting Officer:	Daniel Hendriksen Community Emergency Services Manager
Responsible Officer:	Chadd Hunt Executive Manager Development Services
Voting Requirement	Simple Majority

BRIEF

For Council to request that the Department of Fire and Emergency update the Shires Risk to Resource report.

ATTACHMENTS

Nil.

BACKGROUND / DETAILS

The Shire of Northam's Risk to Resource document was written in 2010 appears to have not been finally endorsed by Council or BFAC. The Shires demographic has changed since then and given the changes that are happening in the western part of the Shire there is a need for a review of the entire document.

It is also apparent that there is some confusion over the model that should be used in preparing the document. Recent information from DFES is that the previously existing model should be used.

CONSIDERATIONS

Strategic Community / Corporate Business Plan

Theme Area 5: Infrastructure & Service Delivery

Outcome 5.2: Environmental risks are proactively managed to minimise impact on residents.

- Continued bushfire management planning and mitigation works; and
- Proactive weed and pest management.

Financial / Resource Implications

Nil.

Bush Fire Advisory Committee Meeting Minutes
14 November 2017



Legislative Compliance

DFES Risk to Resource Model.

Policy Implications

Nil.

Stakeholder Engagement / Consultation

Nil.

Risk Implications

The Risk to Resource Model is a Strategic Plan to base BFB resources in locations related to the level of risk.

OFFICER'S COMMENT

The Risk to Resource Plan for Northam needs to be updated to show our emerging risks and future risks to allocate or request new resources to cover these risks. The Shires Bushfire Service will then have a plan for high risk areas and request that DFES or the Shire supply the appropriate resources to fill the need.

RECOMMENDATION / COMMITTEE DECISION

Minute No: BFAC.168

Moved: Sam Moss

Seconded: Murray McGregor

That Council

1. Request the Department of Fire and Emergency Services (DFES) to review the Shire of Northam's Risk to Resource Plan, in liaison with the Shire of Northam.
2. Request that at the completion of the Risk to Resource Plan review the draft document be presented to a Bush Fire Advisory Committee and subsequently Council meeting for endorsement.

CARRIED 10/0

- Mr Hendriksen advised the purpose of document, outlining that it identifies the level of risk and allocates resources based on this. The document provided in Attachment 1 appears to never have been formally adopted by Council and is now outdated, going back to 2010. It was advised that the document is developed by the Shire in consultation with DFES.

Bush Fire Advisory Committee Meeting Minutes
14 November 2017



- Mr Anderson advised that DFES had put the development of these documents on hold due to their being no ESL funding available to address the level of risk identified however they are now allowing these to be developed.
- If this motion is endorsed by Council the document will be submitted to BFAC and then Council for endorsement.

UNCONFIRMED

Bush Fire Advisory Committee Meeting Minutes
14 November 2017



Attachment 1



LGA Name: The Shire of Northam

Name of Assessor: Mincherton/McQuistan Date: January 2011

FESA Resource to Risk

Guide and Summary Sheets

MINCHERTON Linton

Bakers Hill Bush Fire Brigade

Bush Fire Advisory Committee Meeting Minutes
14 November 2017



Resource to Risk Summary

Guide to using the FESA R2R Process and Summary Sheets

The R2R Process should be conducted every three years (more often if significant changes occur) for each Local Government Authority. Ideally, this exercise should be scheduled so that it can be attended by the LGA officer responsible for community emergency management coordination (CFM, CEM or similar), FESA District Manager and any other significant contributors. The R2R assessment is a useful process for considering the strengths and opportunities that exist in and around a community, as well as revealing threats and weaknesses through risk assessment, analysis and treatments. The R2R process is one where fair distribution and strategic placement of regional resources are considered as the primary consideration, with an emphasis on partnership and shared support among and between communities. The FESA Regional Director will be responsible for making prioritised and evidence-based recommendations to the FESA Capital Grants Committee, based on the collective R2R assessments across the region. The R2R is not intended to be a comprehensive catalogue of all resources or risks in an LGA. It is a process that develops a management plan for an identified risk that is currently considered to be inadequately treated. The information generated by the process should provide a firm foundation for a request for resources to the FESA Grants Committee.

- Stage 1**
- Bushfire Risk and Coverage** – Obtain and analyse the Bushfire Threat Analysis (BTA) maps from Bush Fire & Environmental Protection, Research & Liaison. Print out the isochrone maps for the area being analysed (maps available through FESA District Managers at <http://extranet/sites/volunteers/members/GIS/Pages/TravelTimeMapping.aspx>). To get a complete picture, it may be necessary to also print out adjoining areas' isochrone maps and confirm the accuracy of the locations of existing BPS appliances on the maps¹. Identify at-risk populated locations and/or critical infrastructure that appear to be lacking in adequate cover and note on Stage 1 sheet.
 - LGRC** - Identify at-risk bushfire areas with vulnerable populations using the attached LOCAL GOVERNMENT RESPONSE CRITERIA (Table 2). Document briefly on the Stage 1 sheet.
 - Incident History** - Map out and mark the number and extent of actual level 1 and level 2 wildfire incidents in the immediate vicinity attended or experienced in past 3 years and/or 5 years (if 5 years is significantly different from 3 year profile). Use Westplan - Wildfire to determine level and FIRS to supply latest data.
 - Brigade Profile(s)** - Identify risks (if any) inherent in the local BFB Brigades. Consider training, available personnel, travel time, abilities/ages of volunteers.
 - Available Resources** - List available resources, e.g. volunteers, appliances, tankers, low loaders and graders, etc. Identify whether there are additional resources available elsewhere that may assist during high risk periods. Document potential impact of each.
- Stage 2** With the information provide by Stage 1, use Table 4 to identify risk levels for the communities and/or areas considered at-risk. If Risk Level is 6 or above, consider options for risk reduction/treatment in Stage 3.
- Stage 3** **Prioritised Risk Areas** Briefly state the nature of the risk and the area/population affected.
Risk Reduction/Controls Consider potential methods for risk reduction in general (fuel load management, education, resources available nearby, different appliance, etc.). Is there water carrier capacity available in the vicinity? Consider DEC, private contractors, etc. Identify and document. Document methods considered, potential impact of each, ability of implementing these controls and intent to employ each method. The person responsible for the implementation should be identified in the final column.
Potential Efficiencies Is there an opportunity or need to combine/collocate any units? Could swapping appliances with another area improve response abilities? Discuss and identify this, including implications.
- Stage 4** Review the high risk communities and/or areas identified in Stage 3. Document the new Level of Risk following the introduction of the strategies and processes identified in Stage 2 and detailed on the Risk Treatment Schedule. If Risk Level remains at 6 or above, document controls and treatments for implementation and calculate new Level of Risk.
- Stage 5**
- Identify additional resources required to provide minimum level of protection to the community in case of Level 1 incident and prioritise. If additional resources are outside the ability of the LGA to source locally e.g. BA, Appliance, Building, then document on FESA Grant Request form. Consider appliance type most suitable to meet Level 1 fire response

¹In some areas the data is missing or outdated. Please contact GIS in Perth to update this information, preferably with coordinates from a GPS device. The updated map should be available within 2 weeks.

Bush Fire Advisory Committee Meeting Minutes
14 November 2017



Resource to Risk Summary

criteria (see Table 1) and available trained personnel and infrastructure (has Breathing Apparatus, if identified, met criteria in Table 3)?

- Ensure the attached R2R Summary identifies the at-risk population and geographical area and provides supporting information for alternative controls and treatments considered
- Attach BFS isochrone map(s) identifying the area concerned.
- Identify consequence of not obtaining capital articles on ESL Grant Request form and describe what interim measures are/will be put in place to minimise risk.
- Refer to FIT for Purpose assessments for identified building replacement priorities and include in ESL Grant Request form.
-

Stage 1- Risk Assessment Process	
Method	Notes
1. Bushfire Risk Areas that may have inadequate cover to protect life and property (use BFTA maps and Travel Time maps to assist with identification of these locations)	Population >1500 and growing very quickly. Isochrone: Map shows present turnout would be 10-30 minutes, plus 10-15 minutes to get to appliance. Western end, Chedaring Rd is well outside of the 30 minute turnout and consideration should be given to putting a 1.4 at Wundowie. Volunteer Fire and Rescue Brigade in Wundowie as a joint location. Map show heavy vegetation Rural blocks 12,25,50,1000 hectares Usage, small mixed farming/hobby farms/small village Vegetation: jarrah/marri/wandoo/Dryander forest Water: minimal supplies Bakers Hill, minimum hydrants, standpipe Carlin Valley sub division reticulated hydrants Koojedda sub division reticulated hydrants Brookwood estate reticulated hydrants VERY HIGH BUSH FIRE RISK
2. Local Government Response Criteria	Urban Defensive Up to two fire fighting appliances on site for wildfire in 1 hour(30 + kms between services) 1 fire fighter appliance on site for property threat in 1 hour Specialist Units (ICV on site within 6 hours)
3. Incident History	2006/2007 32 2007/2008 18 2008/2009 28 2009/2010 34 2010/2011 16 Up to 18/01/2011
4. Brigade Profile	Urban Defensive

Bush Fire Advisory Committee Meeting Minutes
14 November 2017



Resource to Risk Summary

	<p>66 members, majority over 40 Training satisfactory for level 1, and low level 2 wildfire No structural FF's. Brigade should move towards Urban Offensive with BA over next 3 years, this will require extensive building upgrade. Training room, BA cleaning area, PPC storage room, drying room etc. Minimal number of FF available for IMT</p> <p>2 Bay shed with minimum conveniences, requires extension in the way of a training room.</p>
5. Available Resources	<p>Appliance types: Other 2.4 R Water tankers, Wundowie Water Cartage (Maybe available) 1.1 Loaders/ graders from the Shire (Minimum of 30-60 minutes)</p>

Stage 2- Communities or areas with Risk Levels at 6 or more

Community/Area Name	Likelihood 1-6	Consequence 1-6	Level of Risk (Likelihood x Consequence)
Bakers Hill area a wildfire - ALL MOST CERTAIN	5	4	20
Bakers Hill area a structural fire - ALL MOST CERTAIN	5	4	20

Stage 3- Risk Controls and Treatment Schedule

Prioritised Risk Statements	Risk Controls/ Options (e.g. Fuel reduction strategies, Strengthen volunteers capacity, Regional Water Tanker Capacity, Partnership formation, Potential Efficiencies)	Impact (High/Med/Low)	Feasibility (High/Med/Low)	Adopt? (Y/N)	Responsible Person/Position and date(s) of Implementation
1. Turnout time to western boundary of the district is outside acceptable times	Introduce 2.4 R to the Bakers Hill Bush Fire district, via dual registration at Wundowie Water Tanker Fire and Rescue Station.	High	High	Yes	Funding
2. Shortage of water	Regional water tanker for the Shire of Northam at Inpiken Bush Fire Brigade	High	High	Yes	

Bush Fire Advisory Committee Meeting Minutes
14 November 2017



FESA Resource to Risk Summary
Fire & Emergency Services
Authority of Western Australia

3. Reserves/UCL	Fuel reduction strategies	High	Medium depending on \$	Funding
4. Structural fire fighting	Upgrade fire appliances to 2-4 Urban with Breathing and relevant building upgrade	Medium	High	Funding
Stage 4 - Revised Risk Profiles with Proposed Controls and Treatments				
Community/Area Name	Proposed Controls (not including major additional ESL resources)	Likelihood 1-5	Consequence 1-5	Level of Risk (Likelihood x Consequence)
Bakers Hill area	Promote hazard reduction and management	5	5	25

Bush Fire Advisory Committee Meeting Minutes
14 November 2017



Resource to Risk Summary

--	--	--	--	--

Stakeholder Name: _____ Title: _____ Signature: _____
Stakeholder Name: _____ Title: _____ Signature: _____

Once completed, please forward copies of this form to the Local Government Authority and the FESA Regional office.

UNCONFIRMED

Bush Fire Advisory Committee Meeting Minutes
14 November 2017

Resource to Risk Summary

Tables

TABLE 1- APPLIANCE TYPES

POPULATION CENTRE	CHARACTERISTICS	APPLIANCE TYPES	COMMENTS
Scattered	<ul style="list-style-type: none"> ✓ Individual homes and out buildings ✓ Situated between settlements or rural centres □ Government Services at settlements and rural centres □ Little public infrastructure on properties ✓ Wildfire risk 	Rural Series LT, R1.4, R2.4, R4.4 Broadacre	
Settlement (up to 500 residents)	<ul style="list-style-type: none"> ✓ Clusters of homes and buildings in central location ✓ Basic infrastructure for day to day living ✓ School/Store and supply facility ✓ Wildfire risk 		Larger Tanker Capacity should be considered in support of settlements
Rural Centre or Outer Urban	<ul style="list-style-type: none"> ✓ Large clusters of homes and buildings □ Infrastructure in place for limited business support □ Shopping sites, welfare facilities, school, medical service ✓ Major roads and airfield, light industrial area ✓ Wildfire risk, some complex structures 	Urban Series 2.4 U 3.4 U	Additional Light Tanker support for urban wildfire interaction to be justified Breathing Apparatus only as per assessment

Table 2 - LOCAL GOVERNMENT RESPONSE CRITERIA

Bush Fire Advisory Committee Meeting Minutes
14 November 2017



FESA Resource to Risk Summary

LOCAL GOVERNMENT RESPONSE CRITERIA

KEY= *Property under threat from wildfire # Turnout time to incident. + Aircraft and/or appropriate machinery where required

BREATHING APPARATUS ALLOCATION CRITERIA (PLEASE TICK)	BREATHING APPARATUS PREREQUISITES (PLEASE TICK)
Appliance: Urban Series U2.A/3.A Town Characteristics: <input checked="" type="checkbox"/> Population - 700 or more; <input checked="" type="checkbox"/> More than 300 houses; <input type="checkbox"/> A hospital and/or some aged care facilities; <input type="checkbox"/> More than 5 public buildings; <input type="checkbox"/> Industrial area(s) with heavy industry capacity and more than 5 sites; <input checked="" type="checkbox"/> Fuel storage areas and/or petrol stations; <input type="checkbox"/> 5 or more sites storing hazardous chemicals; <input checked="" type="checkbox"/> One or more schools with at least 100 pupils; <input type="checkbox"/> A number of retail shops or outlets; <input type="checkbox"/> Office or other commercial developments; and <input type="checkbox"/> An airport, a port facility or large transport depot or facilities; <input type="checkbox"/> No breathing apparatus support within approximately 30 minutes on request	<input checked="" type="checkbox"/> Brigade and Local Government register agreement to provide service <input type="checkbox"/> Brigade has an appropriate urban appliance <input checked="" type="checkbox"/> Brigade has demonstrated a 24/7 roster with a minimum 4 person turn out <input type="checkbox"/> Station has appropriate BA maintenance and cleaning facilities <input checked="" type="checkbox"/> Brigade members willing to meet fitness requirements and facial hair management <input checked="" type="checkbox"/> Brigade members trained to fire fighter (1-12) <input checked="" type="checkbox"/> Brigade members trained in hot fire <input checked="" type="checkbox"/> Brigade members trained in oxygen resuscitation techniques <input type="checkbox"/> Brigade members trained to Breathing Apparatus *requires issuing of - level 2 PPE/BA, Oxy Viva

TABLE 3- BREATHING APPARATUS CHECKLISTS

TABLE 4 - LIKELIHOOD AND CONSEQUENCES - (EMERGENCY MANAGEMENT AUSTRALIA 2004)

LIKELIHOOD	CONSEQUENCE- HUMAN LIFE AND PROPERTY
Rare	1. Less than once in 15 years
Unlikely	2. At least once in 10 years
Moderate	3. At least once in 3 years
Likely	4. At least once per year
Almost Certain	5. More than once per year

LIKELIHOOD	CONSEQUENCE- HUMAN LIFE AND PROPERTY
2. Minor –	No fatalities. Small number of minor injuries. First aid treatment may be required. No people are displaced. Little or no personal support required (support not monetary or material). Inconsequential or no damage.
3. Moderate –	Medical treatment required but no fatalities. Some hospitalisation. Localised displacement of people who return within 24 hours. Personal support satisfied through local arrangements. Local damage, rectified by routine arrangements. Community functioning with some inconvenience.
4. Major –	Possible fatalities. Extensive injuries, significant hospitalisation. Large number displaced (more than 24 hours duration). Extensive resources required for personal support. Significant damage that requires external resources. Community only partially functioning, some services unavailable.
5. Catastrophic –	Significant fatalities. Large number of severe injuries. Extended and large number requiring hospitalisation. General and widespread displacement for extended duration. Extensive damage. Extensive personal support. Community unable to function without significant support.

Bush Fire Advisory Committee Meeting Minutes
14 November 2017



LGA Name: The Shire of Northam

Name of Assessor: Mincherton/McQuistan Date: January 2011

FESA Resource to Risk

Guide and Summary Sheets

Southern Brook Bush Fire Brigade

Linton Mincherton

Bush Fire Advisory Committee Meeting Minutes
14 November 2017



Resource to Risk Summary

Guide to using the FESA R2R Process and Summary Sheets

The R2R Process should be conducted every three years (more often if significant changes occur) for each Local Government Authority. Ideally, this exercise should be scheduled so that it can be attended by the LGA officer responsible for community emergency management coordination (CFM, CEM or similar), FESA District Manager and any other significant contributors. The R2R assessment is a useful process for considering the strengths and opportunities that exist in and around a community, as well as revealing threats and weaknesses through risk assessment, analysis and treatments. The R2R process is one where fair distribution and strategic placement of regional resources are considered as the primary consideration, with an emphasis on partnership and shared support among and between communities. The FESA Regional Director will be responsible for making prioritised and evidence-based recommendations to the FESA Capital Grants Committee, based on the collective R2R assessments across the region. The R2R is not intended to be a comprehensive catalogue of all resources or risks in an LGA. It is a process that develops a management plan for an identified risk that is currently considered to be inadequately treated. The information generated by the process should provide a firm foundation for a request for resources to the FESA Grants Committee.

- Stage 1**
- Bushfire Risk and Coverage** – Obtain and analyse the Bushfire Threat Analysis (BTA) maps from Bush Fire & Environmental Protection, Research & Liaison. Print out the isochrone maps for the area being analysed (maps available through FESA District Managers at <http://extranet/sites/volunteers/members/GIS/Pages/TravelTimeMapping.aspx>). To get a complete picture, it may be necessary to also print out adjoining areas' isochrone maps and confirm the accuracy of the locations of existing BPS appliances on the maps¹. Identify at-risk populated locations and/or critical infrastructure that appear to be lacking in adequate cover and note on Stage 1 sheet.
 - LGRC** - Identify at-risk bushfire areas with vulnerable populations using the attached LOCAL GOVERNMENT RESPONSE CRITERIA (Table 2). Document briefly on the Stage 1 sheet.
 - Incident History** - Map out and mark the number and extent of actual level 1 and level 2 wildfire incidents in the immediate vicinity attended or experienced in past 3 years and/or 5 years (if 5 years is significantly different from 3 year profile). Use Westplan - Wildfire to determine level and FIRS to supply latest data.
 - Brigade Profile(s)** - Identify risks (if any) inherent in the local BFB Brigades. Consider training, available personnel, travel time, abilities/ages of volunteers.
 - Available Resources** - List available resources, e.g. volunteers, appliances, tankers, low loaders and graders, etc. Identify whether there are additional resources available elsewhere that may assist during high risk periods. Document potential impact of each.
- Stage 2**
- With the information provide by Stage 1, use Table 4 to identify risk levels for the communities and/or areas considered at-risk. If Risk Level is 6 or above, consider options for risk reduction/treatment in Stage 3.
- Stage 3**
- Prioritised Risk Areas** Briefly state the nature of the risk and the area/population affected.
- Risk Reduction/Controls** Consider potential methods for risk reduction in general (fuel load management, education, resources available nearby, different appliance, etc.). Is there water carrier capacity available in the vicinity? Consider DEC, private contractors, etc. Identify and document. Document methods considered, potential impact of each, ability of implementing these controls and intent to employ each method. The person responsible for the implementation should be identified in the final column.
- Potential Efficiencies** Is there an opportunity or need to combine/collocate any units? Could swapping appliances with another area improve response abilities? Discuss and identify this, including implications.
- Stage 4**
- Review the high risk communities and/or areas identified in Stage 3. Document the new Level of Risk following the introduction of the strategies and processes identified in Stage 2 and detailed on the Risk Treatment Schedule. If Risk Level remains at 6 or above, document controls and treatments for implementation and calculate new Level of Risk.
- Stage 5**
- Identify additional resources required to provide minimum level of protection to the community in case of Level 1 incident and prioritise. If additional resources are outside the ability of the LGA to source locally e.g. BA, Appliance, Building, then document on FESA Grant Request form. Consider appliance type most suitable to meet Level 1 fire response

¹In some areas the data is missing or outdated. Please contact GIS in Perth to update this information, preferably with coordinates from a GPS device. The updated map should be available within 2 weeks.

Bush Fire Advisory Committee Meeting Minutes
14 November 2017



Resource to Risk Summary

criteria (see Table 1) and available trained personnel and infrastructure (has Breathing Apparatus, if identified, met criteria in Table 3)?

- Ensure the attached R2R Summary identifies the at-risk population and geographical area and provides supporting information for alternative controls and treatments considered
- Attach BFS isochrone map(s) identifying the area concerned.
- Identify consequence of not obtaining capital articles on ESL Grant Request form and describe what interim measures are/will be put in place to minimise risk.
- Refer to FIT for Purpose assessments for identified building replacement priorities and include in ESL Grant Request form.
-

Stage 1- Risk Assessment Process	
Method	Notes
1. Bushfire Risk Areas that may have inadequate cover to protect life and property (use BFTA maps and Travel Time maps to assist with identification of these locations)	Population <200, Isochrone: Map shows present turnout would be 10-30 minutes, plus 10-15 minutes to get to appliance. Map shows broad acre farming Rural blocks 12,25,50,1000 hectares Usage, small mixed farming/hobby farms/mainly broad acre farming Vegetation: York/salmon gum, jam vegetation This area is the beginning of the broad acre farming and hence vegetation is less and large pasture areas, fires are more controllable Water: minimal supplies Broad acre fire rating
2. Local Government Response Criteria	Rural Up to two fire fighting appliances on site for wildfire in 1 hour(30 + kms between services) 1 fire firefighter appliance on site for property threat in 1 hour Specialist Units (ICV on site within 6 hours
3. Incident History	2006/2007 2 2007/2008 1 2008/2009 1 2009/2010 6 2010/2011 0 Up to 18/01/2011
4. Brigade Profile	Rural 47 members, majority over 45 Training satisfactory for level 1, and low level2 wildfire No structural FF's No FF available for IMT

Bush Fire Advisory Committee Meeting Minutes
14 November 2017

Resource to Risk Summary

5. Available Resources	ESL application for 1 bay shed on the Southern Brook Hall site (2010/11, 2011/12 applications) Appliance types: Scattered Other L 4 Rat Antonio's property Water tankers from Northam Water Cartage (Maybe available) Loaders/graders from the Shire (Minimum of 30-60 minutes)
-------------------------------	---

Stage 2- Communities or areas with Risk Levels at 6 or more			
Community/Area Name	Likelihood 1-6	Consequence 1-6	Level of Risk (Likelihood x Consequence)
Southern Brook a wildfire – Likely	4	3	15
Southern Brook area structural fire - Moderate	3	3	9

Stage 3- Risk Controls and Treatment Schedule					
Prioritised Risk Statements	Risk Controls/ Options <small>(eg. Fuel reduction strategies, Strengthen volunteers capacity, Regional Water Tanker Capacity, Partnership formation, Potential Efficiencies)</small>	Impact (High/ Med/Low)	Feasibility (high/ med/low)	Adopt? (Y/N)	Responsible Person/Position and date(s) of Implementation
1. Shortage of water	Regional water tanker for the Shire of Northam or Inopen Bush Fire Brigade	High	High	Yes	Funding
2. Reserves/UCL/Water Corp land	Fuel reduction strategies	High	Medium depending on \$		UCL Funding

Bush Fire Advisory Committee Meeting Minutes
14 November 2017

Resource to Risk Summary

<i>Stage 4 - Revised Risk Profiles with Proposed Controls and Treatments</i>				
Community/Area Name	Proposed Controls (not including major additional ESL resources)	Likelihood 1-5	Consequence 1-5	Level of Risk (Likelihood x Consequence)
Southern Brook BF district	Promote hazard reduction and management	5	5	25

Stakeholder Name: _____ Title: _____ Signature: _____
 Stakeholder Name: _____ Title: _____ Signature: _____

Bush Fire Advisory Committee Meeting Minutes
14 November 2017



Resource to Risk Summary

Once completed, please forward copies of this form to the Local Government Authority and the FESA Regional office.

UNCONFIRMED

Bush Fire Advisory Committee Meeting Minutes
14 November 2017

Resource to Risk Summary

Tables

TABLE 1 - APPLIANCE TYPES

POPULATION CENTRE	CHARACTERISTICS	APPLIANCE TYPES	COMMENTS
Scattered	<ul style="list-style-type: none"> <input checked="" type="checkbox"/> Individual homes and out buildings <input type="checkbox"/> Situated between settlements or rural centres <input type="checkbox"/> Government Services at settlements and rural centres <input type="checkbox"/> Little public infrastructure on properties <input checked="" type="checkbox"/> Wildfire risk 	Rural Series LT, R1.4, R2.4, R4.4 Broadacre	
Settlement (up to 500 residents)	<ul style="list-style-type: none"> <input type="checkbox"/> Clusters of homes and buildings in central location <input type="checkbox"/> Basic infrastructure for day to day living <input type="checkbox"/> School/Store and supply facility <input type="checkbox"/> Wildfire risk 		Larger Tanker Capacity should be considered in support of settlements
Rural Centre or Outer Urban	<ul style="list-style-type: none"> <input type="checkbox"/> Large clusters of homes and buildings <input type="checkbox"/> Infrastructure in place for limited business support <input type="checkbox"/> Shopping sites, welfare facilities, school, medical service <input type="checkbox"/> Major roads and airfield, Light Industrial area <input type="checkbox"/> Wildfire risk, some complex structures 	Urban Series 2.4 U 3.4 U	Additional Light Tanker support for urban wildfire interaction to be justified Breathing Apparatus only as per assessment

Table 2 - LOCAL GOVERNMENT RESPONSE CRITERIA

Bush Fire Advisory Committee Meeting Minutes
14 November 2017

Resource to Risk Summary

LOCAL GOVERNMENT RESPONSE CRITERIA

KEY= *Property under threat from wildfire # Turnout time to incident. + Aircraft and/or appropriate machinery where required

BREATHING APPARATUS ALLOCATION CRITERIA (PLEASE TICK)	BREATHING APPARATUS PREREQUISITES (PLEASE TICK)
Appliance: Urban Series U2.4/3.4 Town Characteristics: <ul style="list-style-type: none"> <input type="checkbox"/> Population - 700 or more; <input type="checkbox"/> More than 300 houses; <input type="checkbox"/> A hospital and/or some aged care facilities; <input type="checkbox"/> More than 5 public buildings; <input type="checkbox"/> Industrial area(s) with heavy industry capacity and more than 5 sites; <input type="checkbox"/> Fuel storage areas and or petrol stations; <input type="checkbox"/> 5 or more sites storing hazardous chemicals; <input type="checkbox"/> One or more schools with at least 100 pupils; <input type="checkbox"/> A number of retail shops or outlets; <input type="checkbox"/> Office or other commercial developments; and <input type="checkbox"/> An airport, a port facility or large transport depot or facilities; <input type="checkbox"/> No breathing apparatus support within approximately 30 minutes on request 	<ul style="list-style-type: none"> <input type="checkbox"/> Brigade and Local Government register agreement to provide service <input type="checkbox"/> Brigade has an appropriate urban appliance <input type="checkbox"/> Brigade has demonstrated a 24/7 roster with a minimum 4 person turn out <input type="checkbox"/> Station has appropriate BA maintenance and cleaning facilities <input type="checkbox"/> Brigade members willing to meet fitness requirements and facial hair management <input type="checkbox"/> Brigade members trained to fire-fighter (1-12) <input type="checkbox"/> Brigade members trained in hot fire <input type="checkbox"/> Brigade members trained in oxygen resuscitation techniques <input type="checkbox"/> Brigade members trained to Breathing Apparatus <p>*Requires Issuing of: level 2 PPE, BA, Oxy Vlna</p>

TABLE 3 - BREATHING APPARATUS CHECKLISTS

TABLE 4 - LIKELIHOOD AND CONSEQUENCES - (EMERGENCY MANAGEMENT AUSTRALIA 2004)

LIKELIHOOD		CONSEQUENCE- HUMAN LIFE AND PROPERTY
Rare	1 Less than once in 15 years	2. Minor - No fatalities. Small number of minor injuries. First aid treatment may be required. No people are displaced. Little or no personal support required (support not monetary or material). Inconsequential or no damage. 3. Moderate- Medical treatment required but no fatalities. Some hospitalisation. Localised displacement of people who return within 24 hours. Personal support satisfied through local arrangements. Local damage, rectified by routine arrangements. Community functioning with some inconvenience. 4. Major - Possible fatalities. Extensive injuries, significant hospitalisation. Large number displaced (more than 24 hours duration). Extensive resources required for personal support. Significant damage that requires external resources. Community only partially functioning, some services unavailable. 5. Catastrophic - Significant fatalities. Large number of severe injuries. Extended and large number requiring hospitalisation. General and widespread displacement for extended duration. Extensive damage. Extensive personal support. Community unable to function without significant support.
Unlikely	2 At least once in 10 years	
Moderate	3 At least once in 3 years	
Likely	4 At least once per year	
Almost Certain	5 More than once per year	

Bush Fire Advisory Committee Meeting Minutes
14 November 2017



LGA Name: The Shire of Northam

Name of Assessor: Mincherton/McQuistan Date: January 2011

FESA Resource to Risk

Guide and Summary Sheets

Jennapullin Bush Fire Brigade

Linton Mincherton

Bush Fire Advisory Committee Meeting Minutes
14 November 2017



FESA Resource to Risk Summary

Guide to using the FESA R2R Process and Summary Sheets

The R2R Process should be conducted every three years (more often if significant changes occur) for each Local Government Authority. Ideally, this exercise should be scheduled so that it can be attended by the LGA officer responsible for community emergency management coordination (CFM, CEM or similar), FESA District Manager and any other significant contributors. The R2R assessment is a useful process for considering the strengths and opportunities that exist in and around a community, as well as revealing threats and weaknesses through risk assessment, analysis and treatments. The R2R process is one where fair distribution and strategic placement of regional resources are considered as the primary consideration, with an emphasis on partnership and shared support among and between communities. The FESA Regional Director will be responsible for making prioritised and evidence-based recommendations to the ESL Capital Grants Committee, based on the collective R2R assessments across the region. The R2R is *not* intended to be a comprehensive catalogue of all resources or risks in an LGA. It is a process that develops a management plan for an identified risk that is currently considered to be inadequately treated. The information generated by the process should provide a firm foundation for a request for resources to the ESL Grants Committee.

- Stage 1**
- Bushfire Risk and Coverage** – Obtain and analyse the Bushfire Threat Analysis (BFTA) maps from Bush Fire & Environmental Protection, Research & Liaison. Print out the isochrone maps for the area being analysed (maps available through FESA District Managers at <http://extranet.shires/volunteers/members/gis/pages/traveltimeMapping.aspx>). To get a complete picture, it may be necessary to also print out adjoining areas' isochrone maps and confirm the accuracy of the locations of existing BPS appliances on the maps¹. Identify at-risk populated locations and/or critical infrastructure that appear to be lacking in adequate cover and note on Stage 1 sheet.
 - LGRC** – Identify at-risk bushfire areas with vulnerable populations using the attached LOCAL GOVERNMENT RESPONSE CRITERIA (Table 2). Document briefly on the Stage 1 sheet.
 - Incident History** – Map out and mark the number and extent of actual level 1 and level 2 wildfire incidents in the immediate vicinity attended or experienced in past 3 years and/or 5 years (if 5 years is significantly different from 3 year profile). Use Westplan – Wildfire to determine level and PIRS to supply latest data.
 - Brigade Profile(s)** – Identify risks (if any) inherent in the local BFB Brigades. Consider training, available personnel, travel time, abilities/ages of volunteers.
 - Available Resources** – List available resources, e.g. volunteers, appliances, tankers, low loaders and graders, etc. Identify whether there are additional resources available elsewhere that may assist during high-risk periods. Document potential impact of each.
- Stage 2** With the information provide by Stage 1, use Table 4 to identify risk levels for the communities and/or areas considered at-risk. If Risk Level is 6 or above, consider options for risk reduction/treatment in Stage 3.
- Stage 3**
- Prioritised Risk Areas** Briefly state the nature of the risk and the area/population affected.
- Risk Reduction/Controls** Consider potential methods for risk reduction in general (fuel load management, education, resources available nearby, different appliance, etc.). Is there water carrier capacity available in the vicinity? Consider DEC, private contractors, etc. Identify and document. Document methods considered, potential impact of each, ability of implementing these controls and intent to employ each method. The person responsible for the implementation should be identified in the final column.
- Potential Efficiencies** Is there an opportunity or need to combine/collocate any units? Could swapping appliances with another area improve response abilities? Discuss and identify this, including implications.
- Stage 4** Review the high risk communities and/or areas identified in Stage 3. Document the new Level of Risk following the introduction of the strategies and processes identified in Stage 2 and detailed on the Risk Treatment Schedule. If Risk Level remains at 6 or above, document controls and treatments for implementation and calculate new Level of Risk.
- Stage 5**
- Identify additional resources required to provide minimum level of protection to the community in case of Level 1 incidents and prioritise. If additional resources are outside the ability of the LGA to source locally e.g. BA, Appliance, Building, then document on ESL Grant Request form. Consider appliance type most suitable to meet Level 1 fire response

¹In some areas the data is missing or outdated. Please contact GIS in Perth to update this information preferably with coordinates from a GPS device. The updated map should be available within 2 weeks.

Bush Fire Advisory Committee Meeting Minutes
14 November 2017



Resource to Risk Summary

criteria (see Table 1) and available trained personnel and infrastructure (has Breathing Apparatus, if identified, met criteria in Table 3)?

- Ensure the attached R2R Summary identifies the at-risk population and geographical area and provides supporting information for alternative controls and treatments considered.
- Attach BFS isochrone map(s) identifying the area concerned.
- Identify consequence of not obtaining capital articles on ESL Grant Request form and describe what interim measures are/will be put in place to minimise risk.
- Refer to RIT for Purpose assessments for identified building replacement priorities and include in ESL Grant Request form.
-

Stage 1- Risk Assessment Process	
Method	Notes
1. Bushfire Risk Areas that may have inadequate cover to protect life and property (use BFTA maps and Travel Time maps to assist with identification of these locations)	Population <100, Isochrone: Map shows present turnout would be 10-30 minutes, plus 10-15 minutes to get to appliance. Map show heavy vegetation Rural blocks 12,25,50,1000 hectares Usage, small mixed farming/hobby farms/mainly broad acre farming Vegetation: York/salmon gum, jam vegetation This area is the beginning of the broad acre farming and hence vegetation is less and large pasture areas, fires are more controllable Water; minimal supplies Broad acre fire rating
2. Local Government Response Criteria	Rural Up to two fire fighting appliances on site for wildfire in 1 hour(30 + kms between services) 1 fire firefighter appliance on site for property threat in 1 hour Specialist Units (ICV on site within 6 hours)
3. Incident History	2006/2007 0 2007/2008 0 2008/2009 0 2009/2010 0 2010/2011 0 Up to 18/01/2011
4. Brigade Profile	Rural 35 members, majority over 30 Training satisfactory for level 1, and low level2 wildfire No structural FF's No FF available for IMT

Bush Fire Advisory Committee Meeting Minutes
14 November 2017

Resource to Risk Summary

5. Available Resources	Farm response only
	Appliance types: Scattered Farm response Loaders/ graders from the Shire (Minimum of 30-60 minutes)
	Other Water tankers from Northam Water Cartage (Maybe available)

Stage 2 - Communities or areas with Risk Levels at 6 or more			
Community/Area Name	Likelihood 1-5	Consequence 1-5	Level of Risk (Likelihood x Consequence)
Jennapullin a wildfire –Unlikely	2	3	6
Southern Brook area structural fire - Moderate	2	3	6

Stage 3 - Risk Controls and Treatment Schedule					
Prioritised Risk Statements	Risk Controls/ Options (e.g. Fuel reduction strategies, Strengthen Volunteers capacity, Regional Water Tanker Capacity, Partnership formation, Potential Efficiencies)	Impact (High/ Med/Low)	Feasibility (high/ med/low)	Adopt? (Y/N)	Responsible Person/Position and date(s) of Implementation
1. Shortage of water	Regional water tanker for the Shire of Northam or Inverm Bush Fire Brigade	High	High	Yes	Funding
2. Reserves/UCL/Water Corp land	Fuel reduction strategies	High	Medium depending on \$		UCL Funding

Bush Fire Advisory Committee Meeting Minutes
14 November 2017





Resource to Risk Summary

<i>Stage 4 - Revised Risk Profiles with Proposed Controls and Treatments</i>				
Community/Area Name	Proposed Controls (not including major additional ESL resources)	Likelihood 1-5	Consequence 1-5	Level of Risk (Likelihood x Consequence)
Jennapullin BF district	Promote hazard reduction and management	5	5	25

Stakeholder Name: _____ Title: _____ Signature: _____
 Stakeholder Name: _____ Title: _____ Signature: _____

Bush Fire Advisory Committee Meeting Minutes
14 November 2017

Resource to Risk Summary

Tables

TABLE 1 - APPLIANCE TYPES

POPULATION CENTRE	CHARACTERISTICS	APPLIANCE TYPES	COMMENTS
Scattered	<ul style="list-style-type: none"> <input checked="" type="checkbox"/> Individual homes and out buildings <input type="checkbox"/> Situated between settlements or rural centres <input type="checkbox"/> Government Services at settlements and rural centres <input type="checkbox"/> Little public infrastructure on properties <input checked="" type="checkbox"/> Wildfire risk 	Rural Series LT, R1.4, R2.4, R4.4 Broadacre	
Settlement (up to 500 residents)	<ul style="list-style-type: none"> <input type="checkbox"/> Clusters of homes and buildings in central location <input type="checkbox"/> Basic infrastructure for day to day living <input type="checkbox"/> School/Store and supply facility <input type="checkbox"/> Wildfire risk 		Larger Tanker Capacity should be considered in support of settlements
Rural Centre or Outer Urban	<ul style="list-style-type: none"> <input type="checkbox"/> Large clusters of homes and buildings <input type="checkbox"/> Infrastructure in place for limited business support <input type="checkbox"/> Shopping sites, welfare facilities, school, medical service <input type="checkbox"/> Major roads and airfield, Light Industrial area <input type="checkbox"/> Wildfire risk, some complex structures 	Urban Series 2.4 U 3.4 U	Additional Light Tanker support for urban wildfire interaction to be justified Breathing Apparatus only as per assessment

Table 2 - LOCAL GOVERNMENT RESPONSE CRITERIA

Bush Fire Advisory Committee Meeting Minutes
14 November 2017

Resource to Risk Summary

LOCAL GOVERNMENT RESPONSE CRITERIA

KEY= *Property under threat from wildfire # Turnout time to incident. + Aircraft and/or appropriate machinery where required

BREATHING APPARATUS ALLOCATION CRITERIA (PLEASE TICK)	BREATHING APPARATUS PREREQUISITES (PLEASE TICK)
Appliance: Urban Series U2.4/3.4 Town Characteristics: <ul style="list-style-type: none"> <input type="checkbox"/> Population - 700 or more; <input type="checkbox"/> More than 300 houses; <input type="checkbox"/> A hospital and/or some aged care facilities; <input type="checkbox"/> More than 5 public buildings; <input type="checkbox"/> Industrial area(s) with heavy industry capacity and more than 5 sites; <input type="checkbox"/> Fuel storage areas and or petrol stations; <input type="checkbox"/> 5 or more sites storing hazardous chemicals; <input type="checkbox"/> One or more schools with at least 100 pupils; <input type="checkbox"/> A number of retail shops or outlets; <input type="checkbox"/> Office or other commercial developments; and <input type="checkbox"/> An airport, a port facility or large transport depot or facilities; <input type="checkbox"/> No breathing apparatus support within approximately 30 minutes on request 	<ul style="list-style-type: none"> <input type="checkbox"/> Brigade and Local Government register agreement to provide service <input type="checkbox"/> Brigade has an appropriate urban appliance <input type="checkbox"/> Brigade has demonstrated a 24/7 roster with a minimum 4 person turn out <input type="checkbox"/> Station has appropriate BA maintenance and cleaning facilities <input type="checkbox"/> Brigade members willing to meet fitness requirements and facial hair management <input type="checkbox"/> Brigade members trained to fire-fighter (1-12) <input type="checkbox"/> Brigade members trained in hot fire <input type="checkbox"/> Brigade members trained in oxygen resuscitation techniques <input type="checkbox"/> Brigade members trained to Breathing Apparatus <p>*Requires Issuing of: level 2 PPE, BA, Oxy Vlna</p>

TABLE 3 - BREATHING APPARATUS CHECKLISTS

TABLE 4 - LIKELIHOOD AND CONSEQUENCES - (EMERGENCY MANAGEMENT AUSTRALIA 2004)

LIKELIHOOD		CONSEQUENCE- HUMAN LIFE AND PROPERTY
Rare	1 Less than once in 15 years	2. Minor - No fatalities. Small number of minor injuries. First aid treatment may be required. No people are displaced. Little or no personal support required (support not monetary or material). Inconsequential or no damage. 3. Moderate- Medical treatment required but no fatalities. Some hospitalisation. Localised displacement of people who return within 24 hours. Personal support satisfied through local arrangements. Local damage, rectified by routine arrangements. Community functioning with some inconvenience. 4. Major - Possible fatalities. Extensive injuries, significant hospitalisation. Large number displaced (more than 24 hours duration). Extensive resources required for personal support. Significant damage that requires external resources. Community only partially functioning, some services unavailable. 5. Catastrophic - Significant fatalities. Large number of severe injuries. Extended and large number requiring hospitalisation. General and widespread displacement for extended duration. Extensive damage. Extensive personal support. Community unable to function without significant support.
Unlikely	2 At least once in 10 years	
Moderate	3 At least once in 3 years	
Likely	4 At least once per year	
Almost Certain	5 More than once per year	

Bush Fire Advisory Committee Meeting Minutes
14 November 2017



LGA Name: The Shire of Northam

Name of Assessor: Mincherton/McQuistan Date: January 2011

FESA Resource to Risk

Guide and Summary Sheets

Irish Town Bush Fire Brigade

Linton Mincherton

Bush Fire Advisory Committee Meeting Minutes
14 November 2017



Resource to Risk Summary

Guide to using the FESA R2R Process and Summary Sheets

The R2R Process should be conducted every three years (more often if significant changes occur) for each Local Government Authority. Ideally, this exercise should be scheduled so that it can be attended by the LGA officer responsible for community emergency management coordination (CFM, CEM or similar), FESA District Manager and any other significant contributors. The R2R assessment is a useful process for considering the strengths and opportunities that exist in and around a community, as well as revealing threats and weaknesses through risk assessment, analysis and treatments. The R2R process is one where fair distribution and strategic placement of regional resources are considered as the primary consideration, with an emphasis on partnership and shared support among and between communities. The FESA Regional Director will be responsible for making prioritised and evidence-based recommendations to the ESL Capital Grants Committee, based on the collective R2R assessments across the region. The R2R is *not* intended to be a comprehensive catalogue of all resources or risks in an LGA. It is a process that develops a management plan for an identified risk that is currently considered to be inadequately treated. The information generated by the process should provide a firm foundation for a request for resources to the ESL Grants Committee.

- Stage 1**
- Bushfire Risk and Coverage** – Obtain and analyse the Bushfire Threat Analysis (BFTA) maps from Bush Fire & Environmental Protection, Research & Liaison. Print out the isochrone maps for the area being analysed (maps available through FESA District Managers at <http://extranet.shires/volunteers/members/gis/pages/traveltimeMapping.aspx>). To get a complete picture, it may be necessary to also print out adjoining areas' isochrone maps and confirm the accuracy of the locations of existing BPS appliances on the maps¹. Identify at-risk populated locations and/or critical infrastructure that appear to be lacking in adequate cover and note on Stage 1 sheet.
 - LGRC** – Identify at-risk bushfire areas with vulnerable populations using the attached LOCAL GOVERNMENT RESPONSE CRITERIA (Table 2). Document briefly on the Stage 1 sheet.
 - Incident History** – Map out and mark the number and extent of actual level 1 and level 2 wildfire incidents in the immediate vicinity attended or experienced in past 3 years and/or 5 years (if 5 years is significantly different from 3 year profile). Use Westplan – Wildfire to determine level and PIRS to supply latest data.
 - Brigade Profile(s)** – Identify risks (if any) inherent in the local BFB Brigades. Consider training, available personnel, travel time, abilities/ages of volunteers.
 - Available Resources** – List available resources, e.g. volunteers, appliances, tankers, low loaders and graders, etc. Identify whether there are additional resources available elsewhere that may assist during high-risk periods. Document potential impact of each.
- Stage 2** With the information provide by Stage 1, use Table 4 to identify risk levels for the communities and/or areas considered at-risk. If Risk Level is 6 or above, consider options for risk reduction/treatment in Stage 3.
- Stage 3**
- Prioritised Risk Areas** Briefly state the nature of the risk and the area/population affected.
- Risk Reduction/Controls** Consider potential methods for risk reduction in general (fuel load management, education, resources available nearby, different appliance, etc.). Is there water carrier capacity available in the vicinity? Consider DEC, private contractors, etc. Identify and document. Document methods considered, potential impact of each, ability of implementing these controls and intent to employ each method. The person responsible for the implementation should be identified in the final column.
- Potential Efficiencies** Is there an opportunity or need to combine/collocate any units? Could swapping appliances with another area improve response abilities? Discuss and identify this, including implications.
- Stage 4** Review the high risk communities and/or areas identified in Stage 3. Document the new Level of Risk following the introduction of the strategies and processes identified in Stage 2 and detailed on the Risk Treatment Schedule. If Risk Level remains at 6 or above, document controls and treatments for implementation and calculate new Level of Risk.
- Stage 5**
- Identify additional resources required to provide minimum level of protection to the community in case of Level 1 incidents and prioritise. If additional resources are outside the ability of the LGA to source locally e.g. BA, Appliance, Building, then document on ESL Grant Request form. Consider appliance type most suitable to meet Level 1 fire response

¹In some areas the data is missing or outdated. Please contact GIS in Perth to update this information preferably with coordinates from a GPS device. The updated map should be available within 2 weeks.

Bush Fire Advisory Committee Meeting Minutes
14 November 2017



Resource to Risk Summary

criteria (see Table 1) and available trained personnel and infrastructure (has Breathing Apparatus, if identified, met criteria in Table 3)?

- Ensure the attached R2R Summary identifies the at-risk population and geographical area and provides supporting information for alternative controls and treatments considered.
- Attach BFS isochrone map(s) identifying the area concerned.
- Identify consequence of not obtaining capital articles on ESL Grant Request form and describe what interim measures are/will be put in place to minimise risk.
- Refer to Fit for Purpose assessments for identified building replacement priorities and include in ESL Grant Request form.
-

Stage 1- Risk Assessment Process	
Method	Notes
1. Bushfire Risk Areas that may have inadequate cover to protect life and property (use BFTA maps and Travel Time maps to assist with identification of these locations)	Population < 500, Isochrone: Map shows present turnout would be 10-30 minutes, plus 10-15 minutes to get to appliance. Map shows broad acre farming Rural blocks 12,25,50,1000 hectares Usage, small mixed farming/hobby farms/broad acre farming Vegetation: York/salmon gum, jam vegetation This area is the beginning of the broad acre farming and hence vegetation is less and large pasture areas, fires are more controllable Water; minimal supplies Broad acre fire rating
2. Local Government Response Criteria	Rural Up to two fire fighting appliances on site for wildfire in 1 hour(30 + kms between services) 1 fire firefighter appliance on site for property threat in 1 hour Specialist Units (ICV on site within 6 hours)
3. Incident History	2006/2007 4 2007/2008 4 2008/2009 11 2009/2010 9 2010/2011 9 Up to 18/01/2011
4. Brigade Profile	Rural 94 members, majority over 55 Training satisfactory for level 1, and low level2 wildfire No structural FF's Minimal number of FF available for IMT

Bush Fire Advisory Committee Meeting Minutes
14 November 2017



FESA Resource to Risk Summary

	Fire shed at Irish Town hall for a 2.4 R & LT. Building upgrade required in the next 5 years Other LT privately housed at Dave Russell's on the western side of district
5. Available Resources	Appliance types: Scattered 2.4 Rat Irish Town Water tankers from Northam Water Cartage (Maybe available) LT at Irish Town Loaders/graders from the Shire (Minimum of 30-60 minutes) LT at Dave Russell's

Stage 2 - Communities or areas with Risk Levels at 6 or more

Community/Area Name	Likelihood 1-5	Consequence 1-5	Level of Risk (Likelihood x Consequence)
Irish Town area a wildfire – ALL MOST CERTAIN	5	3	15
Irish Town area structural fire - LIKELEY	3	3	9

Stage 3 - Risk Controls and Treatment Schedule

Prioritised Risk Statements	Risk Controls/ Options (e.g. Fuel reduction strategies, Strengthen volunteers capacity, Regional Water Tanker Capacity, Partnership formation, Potential Efficiencies)	Impact (High/Med/Low)	Feasibility (high/med/low)	Adopt? (Y/N)	Responsible Person/Position and date(s) of Implementation
1. Shortage of water	Regional water tanker for the Shire of Northam at Ickpen Bush Fire Brigade	High	High	Yes	Funding
2. Reserves/UCL/Water Corp land	Fuel reduction strategies	High	Medium depending on \$		UCL Funding
3. Due to geographical layout and the Avon River		Low	High		Shire to develop further proposal

Bush Fire Advisory Committee Meeting Minutes
14 November 2017



FESA Resource to Risk Summary
Fire & Emergency Services Authority of Western Australia

consideration should be given to development of a new Brigade (Smith, Egoline, Bailey) west of the river					
Stage 4 - Revised Risk Profiles with Proposed Controls and Treatments					
Community/Area Name	Proposed Controls (not including major additional ESL resources)	Likelihood 1-5	Consequence 1-5	Level of Risk (Likelihood x Consequence)	
Irish town BF district	Promote hazard reduction and management	5	5	25	

Stakeholder Name: _____ Title: _____ Signature: _____

Bush Fire Advisory Committee Meeting Minutes
14 November 2017



Resource to Risk Summary

Stakeholder Name: _____ Title: _____ Signature: _____

Once completed, please forward copies of this form to the Local Government Authority and the FESA Regional office.

UNCONFIRMED

Bush Fire Advisory Committee Meeting Minutes
14 November 2017

Resource to Risk Summary

Tables

TABLE 1 - APPLIANCE TYPES

POPULATION CENTRE	CHARACTERISTICS	APPLIANCE TYPES	COMMENTS
Scattered	<ul style="list-style-type: none"> <input checked="" type="checkbox"/> Individual homes and out buildings <input type="checkbox"/> Situated between settlements or rural centres <input type="checkbox"/> Government Services at settlements and rural centres <input type="checkbox"/> Little public infrastructure on properties <input checked="" type="checkbox"/> Wildfire risk 	Rural Series LT, R1.4, R2.4, R4.4 Broadacre	
Settlement (up to 500 residents)	<ul style="list-style-type: none"> <input type="checkbox"/> Clusters of homes and buildings in central location <input type="checkbox"/> Basic infrastructure for day to day living <input type="checkbox"/> School/Store and supply facility <input type="checkbox"/> Wildfire risk 		Larger Tanker Capacity should be considered in support of settlements
Rural Centre or Outer Urban	<ul style="list-style-type: none"> <input type="checkbox"/> Large clusters of homes and buildings <input type="checkbox"/> Infrastructure in place for limited business support <input type="checkbox"/> Shopping sites, welfare facilities, school, medical service <input type="checkbox"/> Major roads and airfield, Light Industrial area <input type="checkbox"/> Wildfire risk, some complex structures 	Urban Series 2.4 U 3.4 U	Additional Light Tanker support for urban wildfire interaction to be justified Breathing Apparatus only as per assessment

Table 2 - LOCAL GOVERNMENT RESPONSE CRITERIA

Bush Fire Advisory Committee Meeting Minutes
14 November 2017

Resource to Risk Summary

LOCAL GOVERNMENT RESPONSE CRITERIA

KEY= *Property under threat from wildfire # Turnout time to incident. + Aircraft and/or appropriate machinery where required

BREATHING APPARATUS ALLOCATION CRITERIA (PLEASE TICK)	BREATHING APPARATUS PREREQUISITES (PLEASE TICK)
Appliance: Urban Series U2.4/3.4 Town Characteristics: <input type="checkbox"/> Population - 700 or more; <input type="checkbox"/> More than 300 houses; <input type="checkbox"/> A hospital and/or some aged care facilities; <input type="checkbox"/> More than 5 public buildings; <input type="checkbox"/> Industrial area(s) with heavy industry capacity and more than 5 sites; <input type="checkbox"/> Fuel storage areas and or petrol stations; <input type="checkbox"/> 5 or more sites storing hazardous chemicals; <input type="checkbox"/> One or more schools with at least 100 pupils; <input type="checkbox"/> A number of retail shops or outlets; <input type="checkbox"/> Office or other commercial developments; and <input type="checkbox"/> An airport, a port facility or large transport depot or facilities; <input type="checkbox"/> No breathing apparatus support within approximately 30 minutes on request	<input type="checkbox"/> Brigade and Local Government register agreement to provide service <input type="checkbox"/> Brigade has an appropriate urban appliance <input type="checkbox"/> Brigade has demonstrated a 24/7 roster with a minimum 4 person turn out <input type="checkbox"/> Station has appropriate BA maintenance and cleaning facilities <input type="checkbox"/> Brigade members willing to meet fitness requirements and facial hair management <input type="checkbox"/> Brigade members trained to fire-fighter (1-12) <input type="checkbox"/> Brigade members trained in hot fire <input type="checkbox"/> Brigade members trained in oxygen resuscitation techniques <input type="checkbox"/> Brigade members trained to Breathing Apparatus *Requires Issuing of: level 2 PPE, BA, Oxy Vlna

TABLE 3 - BREATHING APPARATUS CHECKLISTS

TABLE 4 - LIKELIHOOD AND CONSEQUENCES - (EMERGENCY MANAGEMENT AUSTRALIA 2004)

LIKELIHOOD		CONSEQUENCE- HUMAN LIFE AND PROPERTY
Rare	1 Less than once in 15 years	2. Minor - No fatalities. Small number of minor injuries. First aid treatment may be required. No people are displaced. Little or no personal support required (support not monetary or material). Inconsequential or no damage. 3. Moderate- Medical treatment required but no fatalities. Some hospitalisation. Localised displacement of people who return within 24 hours. Personal support satisfied through local arrangements. Local damage, rectified by routine arrangements. Community functioning with some inconvenience. 4. Major - Possible fatalities. Extensive injuries, significant hospitalisation. Large number displaced (more than 24 hours duration). Extensive resources required for personal support. Significant damage that requires external resources. Community only partially functioning, some services unavailable. 5. Catastrophic - Significant fatalities. Large number of severe injuries. Extended and large number requiring hospitalisation. General and widespread displacement for extended duration. Extensive damage. Extensive personal support. Community unable to function without significant support.
Unlikely	2 At least once in 10 years	
Moderate	3 At least once in 3 years	
Likely	4 At least once per year	
Almost Certain	5 More than once per year	

Bush Fire Advisory Committee Meeting Minutes
14 November 2017



LGA Name: The Shire of Northam

Name of Assessor: Mincherton/McQuistan Date: January 2011

FESA Resource to Risk

Guide and Summary Sheets

Inkpen Bush Fire Brigade

Linton Mincherton

Bush Fire Advisory Committee Meeting Minutes
14 November 2017



Resource to Risk Summary

Guide to using the FESA R2R Process and Summary Sheets

The R2R Process should be conducted every three years (more often if significant changes occur) for each Local Government Authority. Ideally, this exercise should be scheduled so that it can be attended by the LGA officer responsible for community emergency management coordination (CFM, CEM or similar), FESA District Manager and any other significant contributors. The R2R assessment is a useful process for considering the strengths and opportunities that exist in and around a community, as well as revealing threats and weaknesses through risk assessment, analysis and treatments. The R2R process is one where fair distribution and strategic placement of regional resources are considered as the primary consideration, with an emphasis on partnership and shared support among and between communities. The FESA Regional Director will be responsible for making prioritised and evidence-based recommendations to the ESL Capital Grants Committee, based on the collective R2R assessments across the region. The R2R is *not* intended to be a comprehensive catalogue of all resources or risks in an LGA. It is a process that develops a management plan for an identified risk that is currently considered to be inadequately treated. The information generated by the process should provide a firm foundation for a request for resources to the ESL Grants Committee.

- Stage 1**
- Bushfire Risk and Coverage** – Obtain and analyse the Bushfire Threat Analysis (BFTA) maps from Bush Fire & Environmental Protection, Research & Liaison. Print out the isochrone maps for the area being analysed (maps available through FESA District Managers at <http://extranet.shires/volunteers/members/gis/pages/traveltimeMapping.aspx>). To get a complete picture, it may be necessary to also print out adjoining areas' isochrone maps and confirm the accuracy of the locations of existing BPS appliances on the maps¹. Identify at-risk populated locations and/or critical infrastructure that appear to be lacking in adequate cover and note on Stage 1 sheet.
 - LGRC** – Identify at-risk bushfire areas with vulnerable populations using the attached LOCAL GOVERNMENT RESPONSE CRITERIA (Table 2). Document briefly on the Stage 1 sheet.
 - Incident History** – Map out and mark the number and extent of actual level 1 and level 2 wildfire incidents in the immediate vicinity attended or experienced in past 3 years and/or 5 years (if 5 years is significantly different from 3 year profile). Use Westplan – Wildfire to determine level and PIRS to supply latest data.
 - Brigade Profile(s)** – Identify risks (if any) inherent in the local BFB Brigades. Consider training, available personnel, travel time, abilities/ages of volunteers.
 - Available Resources** – List available resources, e.g. volunteers, appliances, tankers, low loaders and graders, etc. Identify whether there are additional resources available elsewhere that may assist during high-risk periods. Document potential impact of each.
- Stage 2** With the information provide by Stage 1, use Table 4 to identify risk levels for the communities and/or areas considered at-risk. If Risk Level is 6 or above, consider options for risk reduction/treatment in Stage 3.
- Stage 3**
- Prioritised Risk Areas** Briefly state the nature of the risk and the area/population affected.
- Risk Reduction/Controls** Consider potential methods for risk reduction in general (fuel load management, education, resources available nearby, different appliance, etc.). Is there water carrier capacity available in the vicinity? Consider DEC, private contractors, etc. Identify and document. Document methods considered, potential impact of each, ability of implementing these controls and intent to employ each method. The person responsible for the implementation should be identified in the final column.
- Potential Efficiencies** Is there an opportunity or need to combine/collocate any units? Could swapping appliances with another area improve response abilities? Discuss and identify this, including implications.
- Stage 4** Review the high risk communities and/or areas identified in Stage 3. Document the new Level of Risk following the introduction of the strategies and processes identified in Stage 2 and detailed on the Risk Treatment Schedule. If Risk Level remains at 6 or above, document controls and treatments for implementation and calculate new Level of Risk.
- Stage 5**
- Identify additional resources required to provide minimum level of protection to the community in case of Level 1 incidents and prioritise. If additional resources are outside the ability of the LGA to source locally e.g. BA, Appliance, Building, then document on ESL Grant Request form. Consider appliance type most suitable to meet Level 1 fire response

¹In some areas the data is missing or outdated. Please contact GIS in Perth to update this information preferably with coordinates from a GPS device. The updated map should be available within 2 weeks.

Bush Fire Advisory Committee Meeting Minutes
14 November 2017



Resource to Risk Summary

criteria (see Table 1) and available trained personnel and infrastructure (has Breathing Apparatus, if identified, met criteria in Table 3)?

- Ensure the attached R2R Summary identifies the at-risk population and geographical area and provides supporting information for alternative controls and treatments considered.
- Attach BPS isochrone map(s) identifying the area concerned.
- Identify consequence of not obtaining capital articles on ESL Grant Request form and describe what interim measures are/will be put in place to minimise risk.
- Refer to Fit for Purpose assessments for identified building replacement priorities and include in ESL Grant Request form.
-

Stage 1- Risk Assessment Process	
Method	Notes
1. Bushfire Risk Areas that may have inadequate cover to protect life and property (use BFTA maps and Travel Time maps to assist with identification of these locations)	Population >700, Isochrone: Map shows present turnout would be 10-30 minutes, plus 10-15 minutes to get to appliance. Map show heavy vegetation Rural blocks 12,25,50,1000 hectares Usage, small mixed farming/hobby farms Vegetation: Jarrah/marri/wandoo/Dryander forest Water; minimal supplies VERY HIGH BUSH FIRE RISK
2. Local Government Response Criteria	Rural Up to two fire fighting appliances on site for wildfire in 1 hour(30 + kms between services) 1 fire firefighter appliance on site for property threat in 1 hour Specialist Units (ICV on site within 6 hours)
3. Incident History	2006/2007 10 2007/2008 6 2008/2009 13 2009/2010 7 2010/2011 7 Up to 18/01/2011.
4. Brigade Profile	Rural 66 members, majority over 55 Training satisfactory for level 1, and low level2 wildfire No structural FF's Minimal number of FF available for IMT NO BRIGADE APPLIANCE SHED. 3 bay shed required with facilities, land being acquired 2011, should be available 2012.

Bush Fire Advisory Committee Meeting Minutes
14 November 2017

Resource to Risk Summary

5. Available Resources	<p>requiring sub division approval.</p> <p>Appliance types: Scattered 2.4 R Water tankers, Wundowie Water Cartage (Maybe available) 1.4R Loaders/ graders from the Shire (Minimum of 30-60 minutes) Brigade Owned: 2 x 2.4R (Old Inter 1970's) Been held by the Brigade due to the shortage of water. Mobile pump required as only available water is from dams, when available</p>
-------------------------------	---

Stage 2- Communities or areas with Risk Levels at 6 or more

Community/Area Name	Likelihood 1-6	Consequence 1-6	Level of Risk (Likelihood x Consequence)
Inkpen area a wildfire – ALL MOST CERTAIN	5	4	20
Inkpen area structural fire - LIKELEY	4	4	16

Stage 3- Risk Controls and Treatment Schedule

Prioritised Risk Statements	Risk Controls/ Options <small>(e.g. Fuel reduction strategies, Strengthen volunteers capacity, Regional Water Tanker Capacity, Partnership formation, Potential Efficiencies)</small>	Impact (High/ Med/Low)	Feasibility (high/ med/low)	Adopt? (Y/N)	Responsible Person/Position and date(s) of Implementation
1. Shortage of water	Regional water tanker for the Shire of Northam at Inkpen Bush Fire Brigade	High	High	Yes	Funding
2. Reserves/UCL/Water Corp land	Fuel reduction strategies	High	Medium depending on \$		UCL Funding

Bush Fire Advisory Committee Meeting Minutes
14 November 2017





Resource to Risk Summary

<i>Stage 4- Revised Risk Profiles with Proposed Controls and Treatments</i>				
Community/Area Name	Proposed Controls (not including major additional ESL resources)	Likelihood 1-5	Consequence 1-5	Level of Risk (Likelihood x Consequence)
Inkpen BF district	Promote hazard reduction and management	5	5	25

Stakeholder Name: _____ Title: _____ Signature: _____

Bush Fire Advisory Committee Meeting Minutes
14 November 2017



Resource to Risk Summary

Stakeholder Name: _____ Title: _____ Signature: _____

Once completed, please forward copies of this form to the Local Government Authority and the FESA Regional office.

UNCONFIRMED

Bush Fire Advisory Committee Meeting Minutes
14 November 2017

Resource to Risk Summary

Tables

TABLE 1- APPLIANCE TYPES

POPULATION CENTRE	CHARACTERISTICS	APPLIANCE TYPES	COMMENTS
Scattered	<input type="checkbox"/> Individual homes and out buildings <input type="checkbox"/> Situated between settlements or rural centres <input type="checkbox"/> Government Services at settlements and rural centres <input type="checkbox"/> Little public infrastructure on properties <input type="checkbox"/> Wildfire risk	Rural Series LT, R1.4, R2.4, R4.4 Broadacre	
Settlement (up to 500 residents)	<input type="checkbox"/> Clusters of homes and buildings in central location <input type="checkbox"/> Basic infrastructure for day to day living <input type="checkbox"/> School/Store and supply facility <input type="checkbox"/> Wildfire risk		Larger Tanker Capacity should be considered in support of settlements
Rural Centre or Outer Urban	<input type="checkbox"/> Large clusters of homes and buildings <input type="checkbox"/> Infrastructure in place for limited business support <input type="checkbox"/> Shopping sites, welfare facilities, school, medical service <input type="checkbox"/> Major roads and airfield, Light Industrial area <input type="checkbox"/> Wildfire risk, some complex structures	Urban Series 2.4 U 3.4 U	Additional Light Tanker support for urban wildfire interaction to be justified Breathing Apparatus only as per assessment

Table 2 - LOCAL GOVERNMENT RESPONSE CRITERIA

Bush Fire Advisory Committee Meeting Minutes
14 November 2017



FESA Resource to Risk Summary

LOCAL GOVERNMENT RESPONSE CRITERIA

KEY= *Property under threat from wildfire # Turnout time to incident. + Aircraft and/or appropriate machinery where required

BREATHING APPARATUS ALLOCATION CRITERIA (PLEASE TICK)	BREATHING APPARATUS PREREQUISITES (PLEASE TICK)
Appliance: Urban Series U2.A/3.A Town Characteristics: <ul style="list-style-type: none"> <input type="checkbox"/> Population - 700 or more; <input type="checkbox"/> More than 300 houses; <input type="checkbox"/> A hospital and/or some aged care facilities; <input type="checkbox"/> More than 5 public buildings; <input type="checkbox"/> Industrial area(s) with heavy industry capacity and more than 5 sites; <input type="checkbox"/> Fuel storage areas and or petrol stations; <input type="checkbox"/> 5 or more sites storing hazardous chemicals; <input type="checkbox"/> One or more schools with at least 100 pupils; <input type="checkbox"/> A number of retail shops or outlets; <input type="checkbox"/> Office or other commercial developments; and <input type="checkbox"/> An airport, a port facility or large transport depot or facilities; <input type="checkbox"/> No breathing apparatus support within approximately 30 minutes on request 	<ul style="list-style-type: none"> <input type="checkbox"/> Brigade and Local Government register agreement to provide service <input type="checkbox"/> Brigade has an appropriate urban appliance <input type="checkbox"/> Brigade has demonstrated a 24/7 roster with a minimum 4 person turn out. <input type="checkbox"/> Station has appropriate BA maintenance and cleaning facilities <input type="checkbox"/> Brigade members willing to meet fitness requirements and facial hair management <input type="checkbox"/> Brigade members trained to fire-fighter (1-12) <input type="checkbox"/> Brigade members trained in hot fire <input type="checkbox"/> Brigade members trained in oxygen resuscitation techniques <input type="checkbox"/> Brigade members trained to Breathing Apparatus <p>*requires Issuing of - level 2 PPE, BA, Oxy Viva</p>

TABLE 3- BREATHING APPARATUS CHECKLISTS

TABLE 4 - LIKELIHOOD AND CONSEQUENCES – (EMERGENCY MANAGEMENT AUSTRALIA 2004)

LIKELIHOOD	CONSEQUENCE- HUMAN LIFE AND PROPERTY
Rare	1. Minor – No fatalities.Small number of minor injuries.First aid treatment may berequired.No people are displaced. Little or no personal support required (support not monetary or material). Inconsequential or no damage
Unlikely	2. Minor – No fatalities.Small number of minor injuries.First aid treatment may berequired.No people are displaced. Little or no personal support required (support not monetary or material). Inconsequential or no damage
Moderate	3. Moderate- Medical treatment required but no fatalities. Some hospitalisation.Localised displacement of people who return within 24 hours.Personal support satisfied through local arrangements.
Likely	4. Major – Possible fatalities.Extensive injuries, significant hospitalisation.Large number displaced (more than 24 hours duration). Extensive resources required for personal support.Significant damage that requires external resources. Community only partially functioning, some services unavailable.
Almost Certain	5. Catastrophic – Significant fatalities.Large number of severe injuries.Extended and large number requiring hospitalisation.General and widespread displacement for extended duration.Extensive damage.Extensive personal support.Community unable to function without significant support.

Bush Fire Advisory Committee Meeting Minutes
14 November 2017



LGA Name: The Shire of Northam

Name of Assessor: Mincherton/McQuistan Date: January 2011

FESA Resource to Risk

Guide and Summary Sheets

Linton Mincherton

Grass Valley Bush Fire Brigade

Bush Fire Advisory Committee Meeting Minutes
14 November 2017



Resource to Risk Summary

Guide to using the FESA R2R Process and Summary Sheets

The R2R Process should be conducted every three years (more often if significant changes occur) for each Local Government Authority. Ideally, this exercise should be scheduled so that it can be attended by the LGA officer responsible for community emergency management coordination (CFM, CFSM or similar), FESA District Manager and any other significant contributors. The R2R assessment is a useful process for considering the strengths and opportunities that exist in and around a community, as well as revealing threats and weaknesses through risk assessment, analysis and treatments. The R2R process is one where fair distribution and strategic placement of regional resources are considered as the primary consideration, with an emphasis on partnership and shared support among and between communities. The FESA Regional Director will be responsible for making prioritised and evidence-based recommendations to the ESL Capital Grants Committee, based on the collective R2R assessments across the region. The R2R is *not* intended to be a comprehensive catalogue of all resources or risks in an LGA. It is a process that develops a management plan for an identified risk that is currently considered to be inadequately treated. The information generated by the process should provide a firm foundation for a request for resources to the ESL Grants Committee.

- Stage 1**
- Bushfire Risk and Coverage** – Obtain and analyse the Bushfire Threat Analysis (BTA) maps from Bush Fire & Environmental Protection, Research & Liaison. Print out the isochrone maps for the area being analysed (maps available through FESA District Managers at <http://extranet/sites/volunteers/members/GIS/Pages/TraysTimeMapping.aspx>). To get a complete picture, it may be necessary to also print out adjoining areas' isochrone maps and confirm the accuracy of the locations of existing BPS appliances on the maps¹. Identify at-risk populated locations and/or critical infrastructure that appear to be lacking in adequate cover and note on Stage 1 sheet.
 - LGRC** - Identify at risk bushfire areas with vulnerable populations using the attached LOCAL GOVERNMENT RESPONSE CRITERIA (Table 2). Document briefly on the Stage 1 sheet.
 - Incident History** - Map out and mark the number and extent of actual level 1 and level 2 wildfire incidents in the immediate vicinity attended or experienced in past 3 years and/or 5 years (if 5 years is significantly different from 3 year profile). Use Westplan – Wildfire to determine level and FIRS to supply latest data.
 - Brigade Profile(s)** - Identify risks (if any) inherent in the local BFB Brigades. Consider training, available personnel, travel time, abilities/ages of volunteers.
 - Available Resources** - List available resources, e.g. volunteers, appliances, tankers, low loaders and graders, etc. Identify whether there are additional resources available elsewhere that may assist during high-risk periods. Document potential impact of each.
- Stage 2** With the information provide by Stage 1, use Table 4 to identify risk levels for the communities and/or areas considered at-risk. If Risk Level is 6 or above, consider options for risk reduction/treatment in Stage 3.
- Stage 3**
- Prioritised Risk Areas** Briefly state the nature of the risk and the area/population affected.
- Risk Reduction/Controls** Consider potential methods for risk reduction in general (fuel load management, education, resources available nearby, different appliance, etc.). Is there water carrier capacity available in the vicinity? Consider DEC, private contractors, etc. Identify and document. Document methods considered, potential impact of each, ability of implementing these controls and intent to employ each method. The person responsible for the implementation should be identified in the final column.
- Potential Efficiencies** Is there an opportunity or need to combine/collocate any units? Could swapping appliances with another area improve response abilities? Discuss and identify this, including implications.
- Stage 4** Review the high risk communities and/or areas identified in Stage 3. Document the new Level of Risk following the introduction of the strategies and processes identified in Stage 2 and detailed on the Risk Treatment Schedule. If Risk Level remains at 6 or above, document controls and treatments for implementation and calculate new Level of Risk.
- Stage 5**
- Identify additional resources required to provide minimum level of protection to the community in case of Level 1 incident and prioritise, if additional resources are outside the ability of the LGA to source locally e.g. BA, Appliance, Building, then document on ESL Grant Request form. Consider appliance type most suitable to meet Level 1 fire response.

¹In some areas the data is missing or outdated. Please contact GIS in Perth to update this information, preferably with coordinates from a GPS device. The updated map should be available within 2 weeks.

Bush Fire Advisory Committee Meeting Minutes
14 November 2017



Resource to Risk Summary

criteria (see Table 1) and available trained personnel and infrastructure (has Breathing Apparatus, if identified, met criteria in Table 3)?

- Ensure the attached R2R Summary identifies the at-risk population and geographical area and provides supporting information for alternative controls and treatments considered.
- Attach BFS isochrone map(s) identifying the area concerned.
- Identify consequence of not obtaining capital articles on ESL Grant Request form and describe what interim measures are/will be put in place to minimise risk.
- Refer to PIT for Purpose assessments for identified building replacement priorities and include in ESL Grant Request form.
-

Stage 1- Risk Assessment Process	
Method	Notes
1. Bushfire Risk Areas that may have inadequate cover to protect life and property (use BFTA maps and Travel Time maps to assist with identification of these locations)	Population > 500, Isochrone: Map shows present turnout would be 10-30 minutes, plus 10-15 minutes to get to appliance. Map show heavy vegetation Rural blocks 12,25,50,1000 hectares Usage, small madalixed farming/hobby farms/broad acre farming Vegetation: Jarrah/marri/wandoo/Dryander forest This area is the beginning of the broad acre farming and hence vegetation is less and large pasture areas, fires are more controllable Water: minimal supplies Broad acre fire rating 2 settlements Grass Valley and Seabrook
2. Local Government Response Criteria	Rural Up to two fire fighting appliances on site for wildfire in 1 hour(30 + kms between services) 1 fire firefighter appliance on site for property threat in 1 hour Specialist Units (ICV on site within 6 hours)
3. Incident History	2006/2007 12 2007/2008 15 2008/2009 14 2009/2010 15 2010/2011 8 Up to 18/01/2011
4. Brigade Profile	Rural 68 members, majority over 45 Training satisfactory for level 1, and low level2 wildfire No structural FF's Minimal number of FF available for IMT

Bush Fire Advisory Committee Meeting Minutes
14 November 2017



FESA Resource to Risk Summary

	Present shed being extended by Brigade, either for a second appliance 1.4 R or as training area. Further facility development required.
5. Available Resources	Appliance types; Scattered 3.4 R Water tankers from Northam Water Cartage (Maybe available) Loaders/ graders from the Shire (Minimum of 30-60 minutes) Other

Stage 2- Communities or areas with Risk Levels at 6 or more			
Community/Area Name	Likelihood 1-5	Consequence 1-5	Level of Risk (Likelihood x Consequence)
Grass Valley area a wildfire - ALL MOST CERTAIN	5	3	15
Grass Valley area structural fire - LIKELEY	3	3	9

Stage 3- Risk Controls and Treatment Schedule					
Prioritised Risk Statements	Risk Controls/ Options (e.g Fuel reduction strategies, Strengthen volunteers capacity, Regional Water Tanker Capacity, Partnership formation, Potential Efficiencies)	Impact (High/Med/Low)	Feasibility (High/med/low)	Adopt? (Y/N)	Responsible Person/Position and date(s) of implementation
1. Light Tanker	Due to delayed back up from nearest Brigades Southern Brook and Irish Town a 1.4 R is urgently required to assist the 3.4 Very dependent on former response	High	High	Yes	Funding
2. Shortage of water	Regional water tanker for the Shire of Northam at Inkipen Bush Fire Brigade	High	High	Yes	Funding

Bush Fire Advisory Committee Meeting Minutes
14 November 2017



FESA Resource to Risk Summary
Fire & Emergency Services
Authority of Western Australia

3. Reserves/UCL/Water Corp land	Fuel reduction strategies	High	Medium depending on \$	UCL Funding
Stage 4- Revised Risk Profiles with Proposed Controls and Treatments				
Community/Area Name	Proposed Controls (not including major additional ESL resources)	Likelihood 1-5	Consequence 1-5	Level of Risk (Likelihood x Consequence)
Grass Valley BF district	Promote hazard reduction and management	5	5	25

Bush Fire Advisory Committee Meeting Minutes
14 November 2017



Resource to Risk Summary

Stakeholder Name: _____ Title: _____ Signature: _____
Stakeholder Name: _____ Title: _____ Signature: _____

Once completed, please forward copies of this form to the Local Government Authority and the FESA Regional office.

UNCONFIRMED

Bush Fire Advisory Committee Meeting Minutes
14 November 2017

Resource to Risk Summary

Tables

TABLE 1- APPLIANCE TYPES

POPULATION CENTRE	CHARACTERISTICS	APPLIANCE TYPES	COMMENTS
Scattered	<input checked="" type="checkbox"/> Individual homes and out buildings <input checked="" type="checkbox"/> Situated between settlements or rural centres <input type="checkbox"/> Government Services at settlements and rural centres <input type="checkbox"/> Little public infrastructure on properties <input checked="" type="checkbox"/> Wildfire risk	Rural Series LT, R1.4, R2.4, R4.4 Broadacre	
Settlement (up to 500 residents) Grass Valley Seabrook	<input checked="" type="checkbox"/> Clusters of homes and buildings in central location <input type="checkbox"/> Basic infrastructure for day to day living <input type="checkbox"/> School/Store and supply facility <input checked="" type="checkbox"/> Wildfire risk		Larger Tanker Capacity should be considered in support of settlements
Rural Centre or Outer Urban	<input type="checkbox"/> Large clusters of homes and buildings <input type="checkbox"/> Infrastructure in place for limited business support <input type="checkbox"/> Shopping sites, welfare facilities, school, medical service <input type="checkbox"/> Major roads and airfield, Light Industrial area <input type="checkbox"/> Wildfire risk, some complex structures	Urban Series 2.4 U 3.4 U	Additional Light Tanker support for urban wildfire interaction to be justified Breathing Apparatus only as per assessment

Table 2 - LOCAL GOVERNMENT RESPONSE CRITERIA

Bush Fire Advisory Committee Meeting Minutes
14 November 2017



FESA Resource to Risk Summary

LOCAL GOVERNMENT RESPONSE CRITERIA

KEY= *Property under threat from wildfire # Turnout time to incident. + Aircraft and/or appropriate machinery where required

BREATHING APPARATUS ALLOCATION CRITERIA (PLEASE TICK)	BREATHING APPARATUS PREREQUISITES (PLEASE TICK)
Appliance: Urban Series U2.A/3.A Town Characteristics: <ul style="list-style-type: none"> <input type="checkbox"/> Population - 700 or more; <input type="checkbox"/> More than 300 houses; <input type="checkbox"/> A hospital and/or some aged care facilities; <input type="checkbox"/> More than 5 public buildings; <input type="checkbox"/> Industrial area(s) with heavy industry capacity and more than 5 sites; <input type="checkbox"/> Fuel storage areas and or petrol stations; <input type="checkbox"/> 5 or more sites storing hazardous chemicals; <input type="checkbox"/> One or more schools with at least 100 pupils; <input type="checkbox"/> A number of retail shops or outlets; <input type="checkbox"/> Office or other commercial developments; and <input type="checkbox"/> An airport, a port facility or large transport depot or facilities; <input type="checkbox"/> No breathing apparatus support within approximately 30 minutes on request 	<ul style="list-style-type: none"> <input type="checkbox"/> Brigade and Local Government register agreement to provide service <input type="checkbox"/> Brigade has an appropriate urban appliance <input type="checkbox"/> Brigade has demonstrated a 24/7 roster with a minimum 4 person turn out. <input type="checkbox"/> Station has appropriate BA maintenance and cleaning facilities <input type="checkbox"/> Brigade members willing to meet fitness requirements and facial hair management <input type="checkbox"/> Brigade members trained to fire-fighter (1-12) <input type="checkbox"/> Brigade members trained in hot fire <input type="checkbox"/> Brigade members trained in oxygen resuscitation techniques <input type="checkbox"/> Brigade members trained to Breathing Apparatus <p>*requires Issuing of - level 2 PPE, BA, Oxy Viva</p>

TABLE 3- BREATHING APPARATUS CHECKLISTS

TABLE 4 - LIKELIHOOD AND CONSEQUENCES – (EMERGENCY MANAGEMENT AUSTRALIA 2004)

LIKELIHOOD	CONSEQUENCE- HUMAN LIFE AND PROPERTY
Rare	1. Less than once in 15 years
Unlikely	2. At least once in 10 years
Moderate	3. At least once in 3 years
Likely	4. At least once per year
Almost Certain	5. More than once per year

2. Minor – No fatalities.Small number of minor injuries.First aid treatment may berequired.No people are displaced. Little or no personal supportrequired (support not monetary or material). Inconsequential or no damage
3. Moderate- Medical treatment required but nofatalities. Some hospitalisation.Localised displacement of peoplewho return within 24 hours.Personal support satisfied throughlocal arrangements. Local damage, rectified by routine arrangements. Community functioning with someinconvenience.
4. Major – Possible fatalities.Extensive injuries, significanthospitalisation.Large number displaced (morethan 24 hours duration). Extensive resources required forpersonal support.Significant damage that requiresexternal resources. Community onlypartially functioning, some servicesunavailable.
5. Catastrophic – Significant fatalities.Large number of severe injuries.Extended and large numberrequiring hospitalisation.General and widespreaddisplacement for extendedduration.Extensive damage.Extensive personal support.Community unable to functionwithout significant support.

Bush Fire Advisory Committee Meeting Minutes
14 November 2017



LGA Name: The Shire of Northam

Name of Assessor: Mincherton/McQuistan Date: January 2011

FESA Resource to Risk

Guide and Summary Sheets

Clackline/Muresk Bush Fire Brigade

MINCHERTON Linton

Bush Fire Advisory Committee Meeting Minutes
14 November 2017



Resource to Risk Summary

Guide to using the FESA R2R Process and Summary Sheets

The R2R Process should be conducted every three years (more often if significant changes occur) for each Local Government Authority. Ideally, this exercise should be scheduled so that it can be attended by the LGA officer responsible for community emergency management coordination (CFM, CFSM or similar), FESA District Manager and any other significant contributors. The R2R assessment is a useful process for considering the strengths and opportunities that exist in and around a community, as well as revealing threats and weaknesses through risk assessment, analysis and treatments. The R2R process is one where fair distribution and strategic placement of regional resources are considered as the primary consideration, with an emphasis on partnership and shared support among and between communities. The FESA Regional Director will be responsible for making prioritised and evidence-based recommendations to the ESL Capital Grants Committee, based on the collective R2R assessments across the region. The R2R is *not* intended to be a comprehensive catalogue of all resources or risks in an LGA. It is a process that develops a management plan for an identified risk that is currently considered to be inadequately treated. The information generated by the process should provide a firm foundation for a request for resources to the ESL Grants Committee.

- Stage 1**
- Bushfire Risk and Coverage** – Obtain and analyse the Bushfire Threat Analysis (BTA) maps from Bush Fire & Environmental Protection, Research & Liaison. Print out the isochrone maps for the area being analysed (maps available through FESA District Managers at <http://extranet/sites/volunteers/members/GIS/Pages/TraysTimeMapping.aspx>). To get a complete picture, it may be necessary to also print out adjoining areas' isochrone maps and confirm the accuracy of the locations of existing BPS appliances on the maps¹. Identify at-risk populated locations and/or critical infrastructure that appear to be lacking in adequate cover and note on Stage 1 sheet.
 - LGRC** - Identify at risk bushfire areas with vulnerable populations using the attached LOCAL GOVERNMENT RESPONSE CRITERIA (Table 2). Document briefly on the Stage 1 sheet.
 - Incident History** - Map out and mark the number and extent of actual level 1 and level 2 wildfire incidents in the immediate vicinity attended or experienced in past 3 years and/or 5 years (if 5 years is significantly different from 3 year profile). Use Westplan – Wildfire to determine level and FIRS to supply latest data.
 - Brigade Profile(s)** - Identify risks (if any) inherent in the local BFB Brigades. Consider training, available personnel, travel time, abilities/ages of volunteers.
 - Available Resources** - List available resources, e.g. volunteers, appliances, tankers, low loaders and graders, etc. Identify whether there are additional resources available elsewhere that may assist during high-risk periods. Document potential impact of each.
- Stage 2** With the information provide by Stage 1, use Table 4 to identify risk levels for the communities and/or areas considered at-risk. If Risk Level is 6 or above, consider options for risk reduction/treatment in Stage 3.
- Stage 3**
- Prioritised Risk Areas** Briefly state the nature of the risk and the area/population affected.
- Risk Reduction/Controls** Consider potential methods for risk reduction in general (fuel load management, education, resources available nearby, different appliance, etc.). Is there water carrier capacity available in the vicinity? Consider DEC, private contractors, etc. Identify and document. Document methods considered, potential impact of each, ability of implementing these controls and intent to employ each method. The person responsible for the implementation should be identified in the final column.
- Potential Efficiencies** Is there an opportunity or need to combine/collocate any units? Could swapping appliances with another area improve response abilities? Discuss and identify this, including implications.
- Stage 4** Review the high risk communities and/or areas identified in Stage 3. Document the new Level of Risk following the introduction of the strategies and processes identified in Stage 2 and detailed on the Risk Treatment Schedule. If Risk Level remains at 6 or above, document controls and treatments for implementation and calculate new Level of Risk.
- Stage 5**
- Identify additional resources required to provide minimum level of protection to the community in case of Level 1 incident and prioritise, if additional resources are outside the ability of the LGA to source locally e.g. BA, Appliance, Building, then document on ESL Grant Request form. Consider appliance type most suitable to meet Level 1 fire response.

¹In some areas the data is missing or outdated. Please contact GIS in Perth to update this information, preferably with coordinates from a GPS device. The updated map should be available within 2 weeks.

Bush Fire Advisory Committee Meeting Minutes
14 November 2017



Resource to Risk Summary

criteria (see Table 1) and available trained personnel and infrastructure (has Breathing Apparatus, if identified, met criteria in Table 3)?

- Ensure the attached R2R Summary identifies the at-risk population and geographical area and provides supporting information for alternative controls and treatments considered.
- Attach BFS Isochrone map(s) identifying the area concerned.
- Identify consequence of not obtaining capital articles on ESL Grant Request form and describe what interim measures are/will be put in place to minimise risk.
- Refer to PIT for Purpose assessments for identified building replacement priorities and include in ESL Grant Request form.
-

Stage 1- Risk Assessment Process	
Method	Notes
1. Bushfire Risk Areas that may have inadequate cover to protect life and property (use BFTA maps and Travel Time maps to assist with identification of these locations)	Population >500 and growing slowly Isochrone: Map shows present turnout would be 10-30 minutes, plus 10-15 minutes to get to appliance. No appliance at the village of Clackline Slip-on at Muresk College, delayed turnout approximately 1 hour Private LT at Spencers Brook, loosely affiliated with Clackline/Muresk Bush Fire Brigade (Not agreed position) Clackline/Muresk Shed, Tighe Road, Warranine. 2.4 Rural LT Bravo Smith Road Shed LT Alpha on present replacement for a 1.4 Map shows heavy vegetation Rural blocks 12,25,50,1000 hectares Usage, small mixed farming/Broadacre/hobby farms/small village, Clackline and Spencer Brook Vegetation: Jarrah/marrri/wandoo/Dryander forest moving into york/salmon gum, jam vegetation Water: minimal supplies Some hydrants Spencers Brook settlement VERY HIGH BUSH FIRE RISK
2. Local Government Response Criteria	Rural Defensive Up to two fire fighting appliances on site for wildfire in 1 hour(30 + kms between services) 1 fire firefighter appliance on site for property threat in 1 hour Specialist Units (ICV on site within 6 hours)
3. Incident History	2006/2007 30 2007/2008 22 2008/2009 25

Bush Fire Advisory Committee Meeting Minutes
14 November 2017



FESA Resource to Risk Summary

	2009/2010 -20 2010/2011 -18 Up to 18/01/2011
4. Brigade Profile	Rural Defensive 50 members, majority over 50 Training satisfactory for level 1, and low level2 wildfire No structural FF's Minimal number of FF available for IMT
5. Available Resources	New 2 Bay shed with minimum conveniences, requires extension in the way of a training room. Appliance types: Other 2.4 R Water tankers, Wundowie Water Cartage (Maybe available) LTBravo or a tanker from Northam (Minimum 1 hour) LTAlpha being replaced with 1.4Loaders/ graders from the Shire (Minimum of 30-60 minutes) Back up from Northam Volunteer FRS for structural (30 minutes)

Stage 2- Communities or areas with Risk Levels at6 or more

Community/Area Name	Likelihood 1-5	Consequence 1-5	Level of Risk (Likelihood x Consequence)
Clackline/Muresk area a wildfire – ALL MOST CERTAIN	5	4	20
Clackline/Muresk area a structural fire –ALL MOST CERTAIN	4	4	16

Stage 3- Risk Controls and Treatment Schedule

Prioritised Risk Statements	Risk Controls/ Options (e.g. Fuel reduction strategies, Strengthen volunteers capacity, Regional Water Tanker Capacity, Partnership formation, Potential Efficiencies)	Impact (High/ Med/Low)	Feasibility (high/ med/low)	Adopt? (Y/N)	Responsible Person/Position and date(s) of Implementation
1. Shortage of water	Regional water tanker for the Shire of Northam at Inlpen Bush Fire Engage	High	High	Yes	

Bush Fire Advisory Committee Meeting Minutes
14 November 2017



FESA Resource to Risk Summary

2. Reserves/UCL	Fuel reduction strategies	High	Medium depending on \$	Funding
3. Due to geographical layout the following needs to be considered and developed over the 5 years	Smith Road LT on the Northern side of the Great Eastern Highway should be considered in a new geographical fire district with further subdivision developments in the Edoline and Bailey Farm area of the Northam/Goodyear road. (5 to 10 years) The private Spencerbrook Brigade indirectly assisted by the Clackline/Muresk Brigade should be considered for LAR. The change in the Muresk Agriculture Facility and the availability of the slip-on. Adds extra risk to this area.	Low	Medium	Shire to develop further proposal
		High	High	Yes Funding
Stage 4- Revised Risk Profiles with Proposed Controls and Treatments				
Community/Area Name	Proposed Controls (not including major additional ESL resources)	Likelihood 1-5	Consequence 1-5	Level of Risk (Likelihood x Consequence)
Clackline/Muresk area	Promote hazard reduction and management	5	5	25

Bush Fire Advisory Committee Meeting Minutes
14 November 2017



FESA Resource to Risk Summary

--	--	--	--	--

Stakeholder Name: _____ Title: _____ Signature: _____
Stakeholder Name: _____ Title: _____ Signature: _____

Once completed, please forward copies of this form to the Local Government Authority and the FESA Regional office.

UNCONFIRMED

Bush Fire Advisory Committee Meeting Minutes
14 November 2017



Resource to Risk Summary

Tables

TABLE 1- APPLIANCE TYPES

POPULATION CENTRE	CHARACTERISTICS	APPLIANCE TYPES	COMMENTS
Scattered	<ul style="list-style-type: none"> <input checked="" type="checkbox"/> Individual homes and out buildings <input checked="" type="checkbox"/> Situated between settlements or rural centres <input type="checkbox"/> Government Services at settlements and rural centres <input type="checkbox"/> Little public infrastructure on properties <input checked="" type="checkbox"/> Wildfire risk 	Rural Series LT, R1.4, R2.4, R4.4 Broadacre	
Settlement (up to 500 residents)	<ul style="list-style-type: none"> <input checked="" type="checkbox"/> Clusters of homes and buildings in central location <input checked="" type="checkbox"/> Basic infrastructure for day to day living <input checked="" type="checkbox"/> School/Store and supply facility <input checked="" type="checkbox"/> Wildfire risk 		Larger Tanker Capacity should be considered in support of settlements
Rural Centre or Outer Urban	<ul style="list-style-type: none"> <input type="checkbox"/> Large clusters of homes and buildings <input type="checkbox"/> Infrastructure in place for limited business support <input type="checkbox"/> Shopping sites, welfare facilities, school, medical service <input checked="" type="checkbox"/> Major roads and airfield, Light Industrial area <input checked="" type="checkbox"/> Wildfire risk, some complex structures 	Urban Series 2.4 U 3.4 U	Additional Light Tanker support for urban wildfire interaction to be justified Breathing Apparatus only as per assessment

Table 2 - LOCAL GOVERNMENT RESPONSE CRITERIA

Bush Fire Advisory Committee Meeting Minutes
14 November 2017



FESA Resource to Risk Summary

LOCAL GOVERNMENT RESPONSE CRITERIA

KEY= *Property under threat from wildfire # Turnout time to incident. + Aircraft and/or appropriate machinery where required

BREATHING APPARATUS ALLOCATION CRITERIA (PLEASE TICK)	BREATHING APPARATUS PREREQUISITES (PLEASE TICK)
Appliance-Urban Series U2.A/3.A Town Characteristics: population - 700 or more; More than 300 houses; <input type="checkbox"/> A hospital and/or some aged care facilities; <input type="checkbox"/> More than 5 public buildings; <input type="checkbox"/> Industrial area(s) with heavy industry capacity and more than 5 sites; Fuel storage areas and or petrol stations; <input type="checkbox"/> 5 or more sites storing hazardous chemicals; One or more schools with at least 100 pupils; <input checked="" type="checkbox"/> A number of retail shops or outlets; <input type="checkbox"/> Office or other commercial developments; and <input type="checkbox"/> An airport, a port facility or large transport depot or facilities; <input type="checkbox"/> No breathing apparatus support within approximately 30 minutes on request	Brigade and Local Government: register agreement to provide service <input type="checkbox"/> Brigade has an appropriate urban appliance Brigade has demonstrated a 24/7 roster with a minimum 4 person turn out <input type="checkbox"/> Station has appropriate BA maintenance and cleaning facilities Brigade members willing to meet fitness requirements and facial hair management Brigade members trained to fire fighter (1-12) Brigade members trained in hot fire Brigade members trained in oxygen resuscitation techniques <input type="checkbox"/> Brigade members trained to Breathing Apparatus *requires issuing of - level 2 PPE, BA, Oxy Viva

TABLE 3- BREATHING APPARATUS CHECKLISTS

TABLE 4 - LIKELIHOOD AND CONSEQUENCES – (EMERGENCY MANAGEMENT AUSTRALIA 2004)

LIKELIHOOD	CONSEQUENCE- HUMAN LIFE AND PROPERTY
Rare	1. Less than once in 15 years
Unlikely	2. At least once in 10 years
Moderate	3. At least once in 3 years
Likely	4. At least once per year
Almost Certain	5. More than once per year

2. Minor – No fatalities.Small number of minor injuries First aid treatment may berequired.No people are displaced. Little or no personal support required (support not monetary or material), Inconsequential or no damage 3. Moderate- Medical treatment required but no fatalities. Some hospitalisation.Localised displacement of peoplewho return within 24 hours.Personal support satisfied throughlocal arrangements. Local damage, rectified by routine arrangements. Community functioning with someinconvenience. 4. Major – Possible fatalities.Extensive injuries, significanthospitalisation.Large number displaced (morethan 24 hours duration). Extensive resources required forpersonal support.Significant damage that requiresexternal resources. Community onlypartially functioning, some servicesunavailable. 5. Catastrophic – Significant fatalities.Large number of severe injuries.Extended and large numberrequiring hospitalisation.General and widespreaddisplacement for extendedduration.Extensive damage.Extensive personal support.Community unable to functionwithout significant support.

Bush Fire Advisory Committee Meeting Agenda
14 November 2017



7. MOTIONS OF WHICH PREVIOUS NOTICE HAS BEEN GIVEN

Blair Wilding entered the meeting at 6:15pm.

7.1 CLACKLINE BFB

At their General meeting on the 15th October 2017 the brigade resolved to put the following two items to BFAC:

7.1.1 Loss of Experience FCO's

Extract from minutes –

It was mentioned that something should be done about the loss of experienced FCO's through the crack down on not completing the qualification even though these members have been fighting fires for years.

Officers Comment:

This issue has been debated a number of times at both Council and at BFAC meetings over a number of years. The current position on training requirements for FCO's was in place for the last fire season, there were no significant issues.

CLACKLINE BFB NOTICE OF MOTION

Moved: Blair Wilding

Seconded: Sam Moss

That Council reconsider the minimum training requirements for Fire Control Officers.

LOST 3/7

- Debate was held around the motion:
 - Arguments for the motion:
 - Loss of FCO's and experience/knowledge.
 - Losing volunteers.
 - Shire has a responsibility to community to have reasonable coverage.
 - Arguments against the motion:
 - Experience has not been lost, as most are still active members of the Brigades.
 - The matter has been considered on a number of occasion and the position of Council has been established.

7.1.2 Membership Issues

Extract from minutes-

Inactive & New Recruits- 30 members on the brigade list that are qualified. Not all members have been active (show up at training/call outs), approx. only 10

Bush Fire Advisory Committee Meeting Agenda
14 November 2017



members consistently turning out. Acknowledge that there are lots of reasons for this – work pressure, retirees travelling, volunteer burn out.

How can we try and get more members: Signs on board 'volunteers needed – call'? Potential members could be mentored on the fire ground while training occurs? Cadets? Roster system (like Toodyay/Mundaring)? DFES help – visiting schools with volunteers? DFES visits to new community members to assess their property and to talk about local brigades and bushfire safety? Attend local markets – one brigade each month? Display in the Boulevard or the new Village Square?

Officers Comment:

Staff are aware of the issue with trying to recruit and retain volunteers within the emergency services sector. DFES have also recently released a document entitle "Western Australian Emergency Services Volunteer Sustainability Strategy 2016-2024. The following link provides some guidance on the work being undertaken by DFES in this area.

<https://www.dfes.wa.gov.au/volunteers/Pages/EmergencyServicesVolunteerSustainabilityStrategy.aspx>

CLACKLINE BFB NOTICE OF MOTION / COMMITTEE DECISION

Minute No: BFAC.169

Moved: Blair Wilding

Seconded: Mathew Macqueen

That Council request the Department of Fire & Emergency Services (DFES) for the provision of a representative to assist the Brigades in liaising with the community to raise awareness about volunteers/bushfire safety and new recruits.

CARRIED 11/0

- Mr Macqueen advised of the purpose and intent of the motion outlining that volunteers are decreasing and awareness needs to be raised in order to address the matter.
- It was raised that the Community Emergency Services Manager is managing approximately 400 volunteers, however only 100 of those are active, in addition to the Brigades. It was advised that further assistance is required to raise awareness.
- Mr Anderson advised that he has no issue with the motion and believed that it is a good idea.
- It was confirmed that DFES has a community engagement section.

Bush Fire Advisory Committee Meeting Agenda
14 November 2017



7.2 BAKERS HILL BFB

The Brigade would like to discuss the DFES Crew Protection System upgrade and the lack of quality of work done for the appliance upgrades.

- No muffler on Diesel Pump with high noise levels
- No Pump controls on the rear pump panel
- Plumbing work and allowances for pump movement

Officers Comment:

Staff agree with the comments as it is an issue and a safety concern. Some issues have been raised with DFES and Clackline 2.4 was returned to DFES to rectify some problems. A letter to DFES to address these concerns may help.

The Brigade believe something should come from BFAC to DFES to suggest improvements.

<p>BAKERS HILL BFB NOTICE OF MOTION / COMMITTEE DECISION</p> <p>Minute No: BFAC.170</p> <p>Moved: Steve Gray Seconded: Matt Macqueen</p> <p>That Council send a letter to the Department of Fire and Emergency Services (DFES) raising the following concerns with the DFES Crew Protection System upgrade:</p> <ul style="list-style-type: none">• No muffler on Diesel Pump with high noise levels;• No Pump controls on the rear pump panel; and• Plumbing work and allowances for pump movement. <p style="text-align: right;">CARRIED 11/0</p>
--

7.3 GRASS VALLEY BFB

At their General meeting on the 6th November 2017 the brigade resolved to put the following items to BFAC:

7.3.2 Brigade Training Records

The Brigade would like to be aware of other members training levels within their brigade and would like to show the training levels on depicted in a graph on whiteboard in the brigade. Members not wishing to allow their records to be displayed can opt out if they desire.

Officers Comment:

Bush Fire Advisory Committee Meeting Agenda
14 November 2017



While staff agree with the concept of providing the training boards it is believed that it is the individual brigade's choice whether or not to have a training board.

<p>Grass Valley Notice of Motion</p> <p>Minute No: BFAC.171</p> <p>Moved: Sam Moss Seconded: Mathew Macqueen</p> <p>That Council recommend brigades to display their members training records on a graph board at each of their stations.</p> <p style="text-align: right;">CARRIED 10/1</p>
--

Mr Moss confirmed that the intent of the motion is not to tell Brigades what to do, it is more raising awareness of what they are doing and 'recommend' it as a practice for other Brigades.

8. URGENT BUSINESS APPROVED BY PERSON PRESIDING OR BY DECISION

7.1 CHANGES TO THE BFAC TERMS OF REFERENCE

Mr Wilding queried why changes were made to the committees Terms of Reference when these were subject to a recent review by a working group appointed by BFAC and Council. Changes include adding an additional Councillor to the committee and also giving the Chief and Deputy Chief Bushfire Control Officers voting rights.

It was also raised that it is difficult to locate minutes from BFAC meetings on the Shire website. The Chief Executive Officer advised that this would be reviewed to ensure they are available for viewing on the Shire of Northam website.

The Chief Executive Officer advised that every two years, after the local government elections, Council is required to reappoint its committees of Council, through this process it adopts the Terms of Reference which outline the rules, requirements, authority etc of the committee. As it is a committee of Council it has the power to determine what these are.

The Chief Executive Officer advised that the Council values the advice that the BFAC provides to Council and this is evident through re-establishing the committee.

The following motion was put forward:

Bush Fire Advisory Committee Meeting Agenda
14 November 2017



MOTION / COMMITTEE DECISION

Minute No: BFAC.172

Moved: Blair Wilding

Seconded: Murray Bow

That Council consult with the Bush Fire Advisory Committee (BFAC) prior to a Council decision for any changes being made to the BFAC Terms of Reference.

CARRIED 11/1

9. DATE OF NEXT MEETING

The next meeting is proposed to be held on 6th March 2017, subject to confirmation.

10. DECLARATION OF CLOSURE

There being no further business the Chairperson, Cr Terry Little declared the meeting closed at 7:04PM.

"I certify that the Minutes of the Bush Fire Advisory Committee meeting held on Tuesday, 14th November 2017 have been confirmed as a true and correct record."

_____ Chairperson

_____ Date

12. OFFICER REPORTS

12.1 **CEO'S** Office

12.1.1 Policy for Information and Communication Technology (ICT) Use – Elected Members

Address:	N/A
Owner:	N/A
File Reference:	2.3.1.2
Reporting Officer:	Alysha Maxwell Executive Assistant - Chief Executive Officer
Responsible Officer:	Jason Whiteaker Chief Executive Officer
Voting Requirement	Simple Majority

BRIEF

For Council to consider adopting a policy for Information and Communication Technology (ICT) Use for its Elected Members.

ATTACHMENTS

Attachment 1: Information and Communication Technology (ICT) Use – Elected Members.

BACKGROUND / DETAILS

In 2015, the Shire of Northam participated in the Local Government Better Practice Review (BPR) Program which was an initiative undertaken by the Department of Local Government and Communities, now known as the Department of Local Government, Sport and Cultural Industries (the Department) to recognise and promote good practice in Western Australian country local governments.

The BPR Program is part of the State Government's Country Local Government Fund (CLGF) Capacity Building Program and involved a review team to work closely with local governments to review key areas of that local government's activities and operations.

Through the review, it was noted that there is a policy in place to provide direction to staff on the usage of computers, email and office equipment, including photocopiers, fax machines, mobiles and other phones. However, the scope does not currently extend to elected members, nor the use of iPads that are provided to elected members. An action was therefore identified on

the Annual Delivery Plan to develop a policy and/or usage agreement, providing direction to elected members as to the appropriate use of communication devices.

CONSIDERATIONS

Strategic Community / Corporate Business Plan

Theme Area 6: Governance & Leadership

Outcome 6.4: The Elected Members of the Shire of Northam provide accountable, strong and effective community leadership.

Financial / Resource Implications

Nil.

Legislative Compliance

N/A.

Policy Implications

There is no current Shire of Northam policy which provides direction to Elected Members in relation to the acceptable ICT use.

Stakeholder Engagement / Consultation

Nil.

Risk Implications

Having a policy in place which provides **direction** to Council's Elected Members will reduce the risk of misuse occurring as there is a clear understanding of the expectations regarding ICT use.

OFFICER'S COMMENT

The BPR Program undertaken by the Department was a beneficial tool which provided Council with an understanding of areas requiring improvement, along with actions that can be taken to ensure good governance. Officers are of the view that a policy such as this is necessary to provide a clear understanding of acceptable use for all Elected Members.

RECOMMENDATION

That Council endorse Policy G1.8, Information and Communication Technology (ICT) Use – Elected Members as provided in Attachment 1.

Attachment 1



*Shire of Northam Planning Policy Manual (Section I)
Policy
G1.8 - Information and Communication Technology (ICT) Use –
Elected Members*

GOVERNANCE

G1.8 Information and Communication Technology (ICT) Use – Elected Members

<i>Responsible Department</i>	Chief Executive Officer
<i>Resolution Number</i>	TBC
<i>Resolution Date</i>	15/11/2017
<i>Next Scheduled Review</i>	November 2019
<i>Related Shire Documents</i>	Shire of Northam Policy Manual Shire of Northam Record Keeping Plan
<i>Related Legislation</i>	<i>Local Government Act 1995 Privacy Act 1988 State Records Act 2000 (WA) Freedom of Information Act 1992 (WA) Broadcasting Services Act 1992 Broadcasting Services Amendment (Online Services) Act 1999 Electronic Transactions Act 1999 Copyright Act 1968</i>

OBJECTIVE

To ensure Elected Members have clear guidelines on the use of the Shire of Northam's Information and Communications Technology (ICT) systems to facilitate their use in a legal and ethical manner

This policy applies to:

- Shire of Northam Elected Members; and
- All aspects of the Shire of Northam's ICT infrastructure, networks, software and hardware collectively referred to as "Shire of Northam ICT infrastructure".

SCOPE

This Policy is designed to guide Elected Members whenever using the Shire's ICT infrastructure.

It covers the Shire of Northam's ICT Infrastructure including transmissions to or through the Shire of Northam's ICT Infrastructure. This Policy governs the use of the Shire of Northam's ICT infrastructure by Elected Members and includes but is not limited to:

- a) Publishing and browsing on the Internet (including Intranet and Extranet);
- b) Downloading or accessing files from the Internet or other electronic sources;
- c) Email;



- d) Electronic bulletins/notice boards;
- e) Electronic discussion/news groups;
- f) Weblogs ('blogs');
- g) File transfer;
- h) File storage;
- i) File sharing;
- j) Video conferencing;
- k) Streaming media;
- l) Instant messaging/mobile phone text messaging;
- m) Online discussion groups and 'chat' facilities;
- n) Subscriptions to list servers, mailing lists or other like services;
- o) Copying, saving or distributing files;
- p) Viewing material electronically;
- q) Printing material; and
- r) Social Media.

Definitions

Authorised Person: means the Chief Executive Officer of the Shire of Northam or a person authorised by the CEO of the Shire of Northam.

ICT Infrastructure: includes but is not limited to, Local Area Networks (LANs), Wide Area Networks (WANs), Wireless Local Area Networks (WLANs), CCTV systems, Radio systems, Intranet, Extranet, Internet, electronic mail (Email), computer systems, software, servers, desktop computers, notebook computers, mobile phones, digital cameras, hand held devices (for example, iPads or tablet devices), USB Memory sticks and other ICT storage devices.

Users: of the Shire of Northam's ICT infrastructure includes all Elected Members who connect to the Shire of Northam's ICT system for the purposes of electronic business.

Personal Use: means all use which is not related to the official role and duties of an Elected Member, and includes all private internet usage and emails.

Electronic Communications: means email, instant messaging and any other material sent electronically.

Shire: means the Shire of Northam.

POLICY

The Shire of Northam's ICT infrastructure must be properly and efficiently used and are not to be tampered with or altered.

The provision of the ICT infrastructure by the Shire to Elected Members is to facilitate and enhance the conduct of Elected Members business and functions.

Acceptable Use



The Shire's ICT infrastructure are not to be used for illegal, offensive or other inappropriate activities.

Personal Use

Personal use of Council owned or provided ICT resources means those activities conducted for purposes other than the official business, role or duties, or professional development of the Elected Member. Personal use is permitted under the following conditions or limitations:

- a) Does not interfere or contradict any of the illegal, offensive or other inappropriate activities;
- b) Incurs minimal additional expense to Council;
- c) Does not interfere with the operation of Council and does not take place during the official business of the Council e.g. during a Council meeting.
- d) Interferes with the intended use of resources. Such activities may include the downloading large amounts of data;
- e) Will withstand public scrutiny and not bring an employee of the Council, a Councillor or Council into disrepute;
- f) Any information created, transmitted or stored for personal purposes will not be the responsibility of the Council; and
- g) Information resulting from personal usage may be subject to scrutiny and/or audit at any time.

Copyright

The Shire of Northam supports the rights of copyright owners and does not and will not tolerate reckless or deliberate copyright infringement. Refer to the Copyright Act 1968 for further information.

Shire Property

The Shire of Northam is the owner of, and asserts copyright over;

- a) All electronic communications created by employees as part of their employment and sent through the Shire of Northam's ICT infrastructure.
- b) All electronic data / information stored on the Shire of Northam's ICT infrastructure.

Electronic communications created, sent or received by the users are the property of the Shire of Northam, and may be accessed as records of evidence in the case of an investigation. Electronic communications may also be subject to discovery in litigation and criminal investigations. This is subject to Commonwealth or State law that precludes such access.

Confidentiality

Electronic communication is not a secure means of communication. While every attempt is made to ensure the security of the Shire of Northam's ICT infrastructure, users must be aware that this security is not guaranteed, particularly when communicated to an external party. The sender should consider the confidentiality of the material they intend to send when choosing the appropriate means of communication.



Attribution

There is always a risk of false attribution which results in breaches of this Policy. It is possible that communications may be modified to reflect a false message, sender or recipient. In these instances an individual may be unaware that he or she is communicating with an impostor or receiving fraudulent information. If a user has a concern with the contents of a message received or the identity of the publisher of the electronic information, action should be taken to verify their identity by other means. If a user believes an electronic communication has been intercepted or modified, the Authorised Person must be informed.

Monitoring

Use of the Shire of Northam's ICT infrastructure may be monitored by Authorised Persons.

From time to time, Authorised Persons may examine or monitor the records of Shire's ICT infrastructure including for operational, maintenance, compliance, auditing, security or investigative purposes. For example, electronic communications and web sites visited may be monitored. The Shire of Northam may investigate a complaint arising from the use of the Shire of Northam's ICT infrastructure.

Use of the Shire of Northam's ICT infrastructure is provided to users on condition that it is agreed that the Shire of Northam's ICT infrastructure are monitored in accordance with this Policy. Use of the Shire of Northam's ICT infrastructure constitutes consent to monitoring in accordance with this Policy.

Security

Users must maintain awareness of current email threats, including taking care when reading emails.

Initial password will be set for users and changed every three months, this will be undertaken through the assistance of the Information and Communication Technology Officer. User-IDs and passwords must be kept secure and confidential. User-IDs and passwords should not be disclosed to anyone. Users must not allow or facilitate unauthorised access to the Shire's ICT infrastructure through the disclosure or sharing of passwords or other information designed for security purposes.

Records Management

Electronic Communications are public records and subject to the provisions of the State Records Act (2000).

The Shire of Northam's management of email messages must comply with the Shire of Northam's Records Management Plan, processes and procedures on recordkeeping and management of electronic communications, these may be amended from time to time.



Records that are to be recorded on the Shire of Northam's Records Management Systems must be emailed to Records at records@northam.wa.gov.au.

Responsibility

It is the responsibility of the Chief Executive Officer to ensure that the people to whom this Policy applies are aware of this Policy. This may include, but is not limited to:

- a) Providing access to a copy of the Policy;
- b) Reminders of the need for compliance with the Policy; and
- c) Providing updates or developments of the Policy to those affected by the Policy.

It is the responsibility of all users to abide by this Policy.

Users of the Shire's ICT system are subject to Acts and Regulations not explicitly referenced in this policy. These include, but are not restricted to:

- a) Privacy Act 1988 Commonwealth of Australia;
- b) Freedom from Information Act 1982 Commonwealth of Australia;
- c) Freedom from Information Act 1992 State of Western Australia;
- d) Crime Act 1914 Commonwealth of Australia;
- e) Criminal Code Act 1995 Commonwealth of Australia; and
- f) Australian Crimes Commission Act 2002 Commonwealth of Australia.

Users are accountable for all use of the Shire's ICT infrastructure that have been made available to them for purposes of undertaking their role and duties as an Elected Member. Users must maintain full supervision and physical control of the Shire of Northam's ICT equipment at all times.

Users should exercise care when using IT equipment. Users will be held responsible for cost of repair if it is deemed that damage is caused through misuse or negligence. Damaged equipment that may cause harm must not be used. Damage to equipment must be reported to the Chief Executive Officer.

Disclaimer

All emails sent externally from the Shire of Northam will have a disclaimer placed along with the Elected Members signature. The current disclaimer is worded as follows:

"If you are not the intended recipient, please advise by return e-mail immediately, and delete the e-mail and any attachments without using or disclosing the contents in any way. The views expressed in this e-mail are those of the author, and do not represent those of the Shire of Northam unless this is clearly indicated. You should scan this e-mail and any attachments for viruses. The Shire of Northam accepts no liability for any direct or indirect damage or loss resulting from the use of any attachments to this e-mail."

This disclaimer must not be altered or interfered with in any way, except by the Authorised Person. The use of this disclaimer may not necessarily prevent the Shire of Northam or the sender of the email from being held liable for its content.



Shire of Northam Planning Policy Manual (Section I)
Policy
G1.8 - Information and Communication Technology (ICT) Use –
Elected Members

Complaints

If you wish to make a complaint about an electronic communication that is offensive or inappropriate, this is to be raised with the Chief Executive Officer.

Non-compliance

Non-compliance with this Policy will be regarded as a serious matter and appropriate action may be taken.

Agreement

I, _____ (please print) the undersigned, acknowledge that I have read and understand the Shire of Northam's Policy G1.8 - Information and Communication Technology (ICT) Acceptable Use – Elected Members and agree to act in accordance with the provisions of this policy.

Signed _____

Date _____

12.2 ENGINEERING SERVICES

Nil.

12.3 DEVELOPMENT SERVICES

12.3.1 Mid-West Wheatbelt (Central) Joint Development Assessment Panel (Wheatbelt Joint DAP) - Local Government Nominations

Address:	N/A
Owner:	N/A
File Reference:	3.1.9.1
Reporting Officer:	Kobus Nieuwoudt Manager Planning Services
Responsible Officer:	Chadd Hunt Executive Manager Development Services
Voting Requirement	Simple Majority

BRIEF

Council is required to re-nominate for the Minister's consideration, two elected members to act as representatives, and two elected members to act as proxy representatives for the Shire of Northam on the Mid-west Wheatbelt (Central) Joint Development Assessment Panel (Wheatbelt Joint DAP). This is due to the October local government elections and three existing members' not being re-elected to Council.

ATTACHMENTS

Nil.

BACKGROUND / DETAILS

On 25th January 2017, Council resolved the following:

RECOMMENDATION / COUNCIL DECISION

Minute No: C.2927

Moved: Cr Rumjantsev

Seconded: Cr Hughes

That Council:

- 1. Appoints as local members on the Mid-West Wheatbelt (Central) Joint Development Assessment Panel –
Cr Ulo Rumjantsev; and
Cr Denis Beresford*
- 2. Appoints as alternate local members (proxies) on the Mid-West Wheatbelt (Central) Joint Development Assessment Panel –*

*Cr Des Hughes; and
Cr Julie Williams.*

CARRIED 9/0

Under regulation 26 of the *Planning and Development (Development Assessment Panels) Regulations 2011*, Council is required to nominate four elected members of the Council, comprising two local members and two alternate local members to sit on the Wheatbelt Joint DAP.

Cr Williams is a current proxy, however as three of the four members nominated were not re-elected, Council is now required to re-nominate members to the Wheatbelt Joint DAP for the Minister's consideration.

About DAPs

As a key component of planning reform in Western Australia, DAPs are intended to enhance planning expertise in decision-making by improving the balance between technical advice and local knowledge.

Each DAP consists of five panel members, three being specialist members and two local government councillors.

Under the DAP regulations, each DAP (there are 8 JDAPs in WA) will determine development applications that meet set type and value thresholds as if it were the responsible authority under the relevant planning instrument, such as the local planning scheme or region planning scheme. The DAP regulations state that DAP applications cannot be determined by local government or the Western Australian Planning Commission (WAPC).

Administration of DAPs

Under the DAP regulations, DAPs must be administered by an officer(s) of the Department of Planning, and the CEO of the Department must establish a DAP website.

Development Assessment Panels report directly to the Minister for Planning, and do not form part of the Department of Planning or the Western Australian Planning Commission.

CONSIDERATIONS

Strategic Community / Corporate Business Plan

Theme Area 6: Governance & Leadership

Outcome 6.4: The Elected Members of the Shire of Northam provide accountable, strong and effective community leadership.

Financial / Resource Implications

There are no financial and/or resource implications for the Shire as a result of the recommendations from this report.

Legislative Compliance

Pursuant to Regulation 26 (1) of the *Planning and Development (Development Assessment Panels) Regulations 2011* (the DAP regulations), the Minister for Planning must cause to be established and maintained a register of local government members of Joint Development Assessment Panels (JDAPs).

The register must include the names of 2 members of the council of each local government of a district for which a JDAP is established. Following receipt of all local government nominations, the Hon. Minister for Planning will consider and appoint nominees for up to a three-year term, expiring on 26 April 2020. All appointed local members will be placed on the local government member register and advised of DAP training dates and times.

Policy Implications

There are no policy implications for the Shire of the recommendations of this report.

Stake Holder Engagement / Consultation

Nil.

Risk Implications

It is considered there are no risk implications for the Shire of the recommendations of this report.

OFFICER'S COMMENT

It is a mandatory requirement, pursuant to the DAP regulations, that all DAP members attend training before they can sit on a DAP and determine applications. Local government members who have previously undertaken training are not required to attend further training.

When selecting nominees, Council should consider that upcoming local government elections may result in a change to DAP membership if current councillors, who are DAP members, are not re-elected.

At the time of writing this report, no nominations have been received.

RECOMMENDATION

That Council:

1. Appoints as local members on the Mid-West Wheatbelt (Central) Joint Development Assessment Panel –
 - Cr _____; and
 - Cr _____

2. Appoints as alternate local members (proxies) on the Mid-West Wheatbelt (Central) Joint Development Assessment Panel –
 - Cr _____; and
 - Cr _____

12.3.2 Application for Development Approval – Northam Youth Space -
Northam Recreation Precinct, Northam

Address:	Lot 217 Peel Terrace Northam
Owner:	Shire of Northam
File Reference:	A14137/P
Reporting Officer:	Chadd Hunt Executive Manager Development Services
Responsible Officer:	Chadd Hunt Executive Manager Development Services
Voting Requirement	Simple Majority

BRIEF

Council approval is required for the construction of the Northam Youth Space located within the area known as the Northam Recreation Precinct. The matter is being referred to Council as during the public consultation phase objections to the proposal have been raised.

ATTACHMENTS

- Attachment 1: Location Plan.
- Attachment 2: Sketch Design.
- Attachment 3: Concept Report.
- Attachment 4: Schedule of Submissions.

BACKGROUND / DETAILS

Council resolved on 21st June 2017 the preferred location for the Northam Youth Space. After consideration of a number of options the Northam Recreation Precinct was chosen as the preferred location. The Council resolved the following:

That Council:

- 1. Receive the Northam Youth Precinct Community Engagement Report;*
- 2. Endorse Jubilee Recreation Precinct as the preferred location for the Youth Precinct;*
- 3 Authorise the Chief Executive Officer to commence design and construction of the Youth space; and*
- 4. Request the Chief Executive Officer to seek alternative funding opportunities to offset the capital cost of the project.*

Lot 217 Peel Terrace, Northam has an area of (5.9 hectares and contains infrastructure such the Jubilee Oval, Jubilee Pavilion, Northam SES headquarters and Northam Agricultural Society Pavilion and associated ancillary building (refer to attached location plan).

Lot 217 and other properties either owned freehold or under the management of Council form part of the Northam Recreation Precinct which includes the Northam Recreation Centre, BMX track, Henry Street Oval and Fire Brigade Running track.

The land is zoned "Parks and Recreation" with a designated purpose of Recreation under the provisions of local planning Scheme No 6.

CONSIDERATIONS

Strategic Community / Corporate Business Plan

Theme Area 2: Community Wellbeing

Outcome 2.1: People in the Shire of Northam feel that their community is caring and inclusive.

Outcome 2.2: There are a variety of recreation and leisure activities available for all ages, across the Shire of Northam.

Action: Facilitate development of the Northam Youth Space/Skate Park.

Financial / Resource Implications

Council has allocated \$859,411 in the 2017-18 Budget for the development of the Northam Youth Space.

At the Strategic Council meeting held in August 2017 discussion was held with respect to attracting additional funding to complete all stages of the project with an estimated cost of \$1.5 million. Staff have been exploring additional funding for the project however at the time of completing this report no further information was available.

Legislative Compliance

Shire of Northam Local Planning Scheme No. 6 (LPS6)

Under the provisions of LPS6, the development of land zoned Reserve is covered by Clause 3.2.2 which states –

" 2.3.2 In determining an application for development approval the local government is to have due regard to –

(a) the matters set out in Clause 67 of the deemed provisions.

(b) the ultimate purpose intended for the Reserve."

Planning and Development (Local Planning Schemes) Regulations 2015(deemed provisions referred to above)

Clause	Criteria	LPP / Scheme Provision	Proposed by Development	Criteria Met / Condition Required
LPS Reg. 67(h)	Any structure plan, activity centre plan or local development plan that relates to the development	Previous resolution by Council for this location	Complies with previous resolution	Yes
LPS Reg. 67(j)	In the case of land reserved under this Scheme, the objectives for the reserve	Purpose of Reserve is Recreation		Yes
LPS Reg. 67(m)	Compatibility of development	Relationship of development	Located in northern section of property	Yes
LPS Reg. 67(n)	Amenity of locality	Environmental impacts; character of locality; social impacts.	Social issues will need to be managed as withal Council reserves and facilities	Condition re lighting and proposed operating hours imposed
LPS Reg. 67(o)	Environmental impacts	Effect of development of natural environment and water sources.	No vegetation removal proposed	.Yes
LPS Reg. 67(p)	Landscaping	Provision for landscaping made. Whether trees should be preserved.	All trees proposed to be retained	Yes
LPS Reg. 67(q)	Natural constraints	Suitability of land from flooding, bushfire, etc	Portion of land is subject to inundation during major rainfall events	Drainage condition imposed
LPS Reg. 67(t)	Traffic generation	Capacity of road network and effect.	Road network suitable	Yes
LPS Reg. 67 (u)	Accessibility		Footpath network suitable	Yes
LPS Reg. 67. (w)	History of the site		Site has significant history – historic gates to remain and become a feature	Yes
LPS Reg. 67 (x)	Community Impact		Will be of major benefit to the Youth of the Region	Yes

Clause	Criteria	LPP / Scheme Provision	Proposed by Development	Criteria Met / Condition Required
LPS Reg. 67(y) & LPP20	Submissions received	Application advertising to adjoining landowners and the general public.	Three submissions were received raising concerns about the proposal.	Refer to Schedule of submissions.

Policy Implications

There are no policy implications associated with this proposal. The proposal can be conditioned to meet the provisions of LPS6, the Regulations and to address the issues raised in the submissions.

Stakeholder Engagement / Consultation

The development of the Youth Space has been the subject of a number of consultations and meetings including:

- Design Workshops and consultation – January-March 2017;
- Council Meeting 21 June 2017 Council determination of preferred location;
- Strategic Council Meeting 23 August 2017 - presentation of latest concept designs;
- Community Workshop 31 August 2017- presentation of concept designs; and
- Neighbour Consultation –9th to 27 November 2017 – letters sent to adjoining property owners, placed on Shire website.

Risk Implications

There is no real risk for Council in approving the youth space in the current location.

OFFICER'S COMMENT

The development of the Northam Youth space is a significant community project that will provide a modern facility for youth in the region. Notwithstanding that there will be impacts on other users of the precinct in **staff's opinion these issues** can be managed through negotiation during event organisation.

The entire recreation precinct has been subject to ongoing significant planning and development over recent years and with the development of the new aquatic centre will become a real hub for community activity.

The management of the facility on an ongoing basis will be required to ensure that the facility is utilised for the purposed intended.

RECOMMENDATION

That Council grant Development for the construction of a Youth Space facility at Lot 217 (44) Peel Terrace, Northam as outlined in the Application received 19 October 2017 (Application No.P17097), subject to the following conditions:

“That Council grant Development Approval in accordance with the provisions of Shire of Northam Local Planning Scheme No. 6 to the for the construction of the Northam Youth Space, subject to the following conditions:

General conditions

1. The development hereby permitted must substantially commence within two years from the date of this determination notice.
2. The development hereby permitted taking place in accordance with the stamped approved plans.
3. No advertisements, other than an exempt business identification sign, shall be displayed without the prior approval of the local government.
4. The stormwater shall be discharged in a manner so that there is no discharge onto the adjoining properties to the satisfaction of the local government.

Conditions to be met prior to commencement of works and/or use

5. Prior to commencement of development, outdoor lighting plans must be submitted and approved by the Executive Manager Development Services. The outdoor lighting is to be designed, baffled and located to prevent any increase in light spill onto the adjoining properties.

Conditions requiring ongoing compliance

6. The on-site drainage system shall be maintained on an ongoing basis to the satisfaction of the local government.
7. Any lighting systems or Wi-Fi for the Youth space is to operate until 10pm Sunday to Thursday and 11pm Friday and Saturday nights unless otherwise approved by the Chief Executive Officer.

Attachment 1

02

JUBILEE RECREATION PRECINCT

UNDERSTANDING SITE CONTEXT

The location of the site designated for the NYP forms part of the Jubilee Recreation Precinct. The prospective site presents an opportunity for the Shire of Northam to develop a youth precinct in a vestige of unused space. Easily accessible by vehicle and public transport, the space is accessible to all demographics and provides the opportunity to lift the public profile of youth within the community.

Historically, the site has been used by the Agricultural Society as showgrounds for the Northam Show over a two day period in September of every year. The precinct provides adequate space to allow for the relocation of the show and its supporting infrastructure while the historic use of the site can be used to influence the design of the facility, forming links to its cultural heritage.

The redevelopment of the site will create a central hub for the young people of Northam, while further activating the Jubilee Recreation Precinct. Other activities within this precinct include BMX racing, traditional sports such as cricket, footy, netball and basketball, other indoor sports and the proposed relocation of the Northam swimming pool.

With the existing historic features and proposed development of the site, the facility will create a dynamic and activated central community hub to offer recreational and social experiences for all members of the community, from day to day usage to larger community events. As one of the foremost youth precincts within the area it will be a strategic public realm hub for Northam and its wider community.

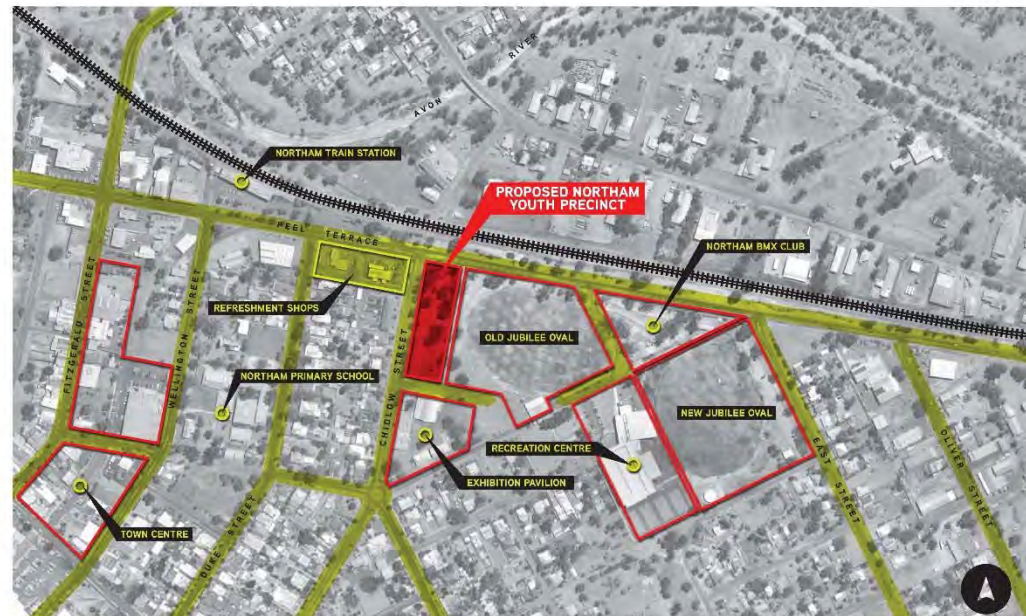

03

SITE ANALYSIS

DISTANCE TO RESIDENTS

Youth facilities have the capability to be loud places due to the excitement and highly active users within the space. Generally from past experience, Convic has found that a 50m offset from the closest residential properties provides enough buffer for the noise to disperse.

Residential properties on the eastern side of Chidlow Street are within close proximity to the site and exploration into the placement of different activities on the site needs to be undertaken during the concept development phase to ensure the higher level of activity is not within the 50m offset.

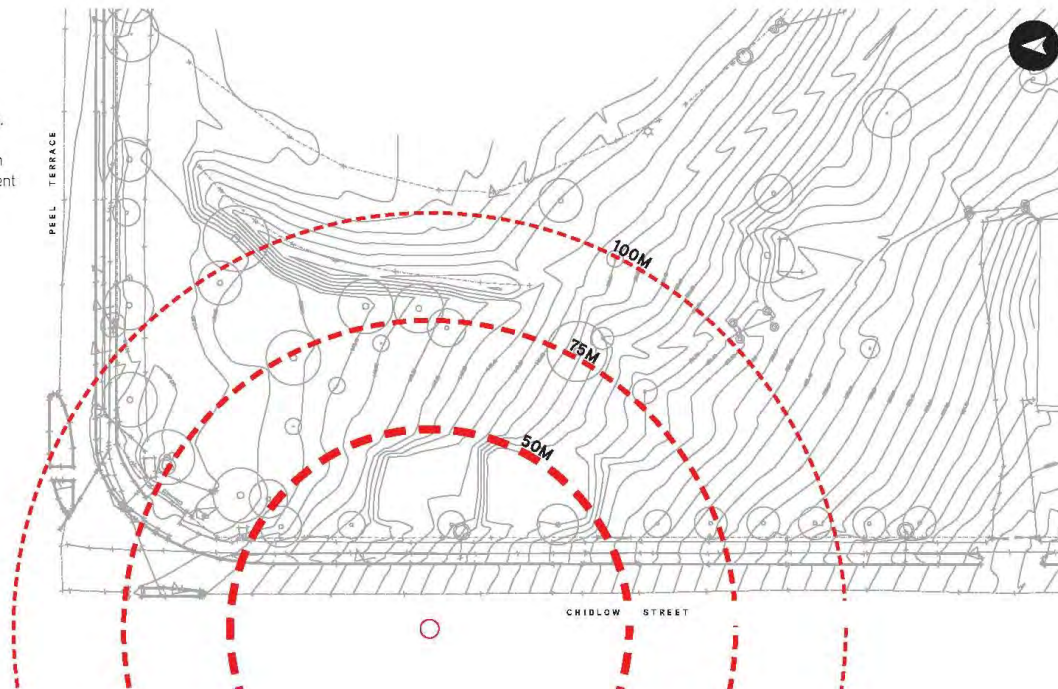

10

FINAL CONCEPT DESIGN

YOUTH PRECINCT LEGEND

- 1 Formal Entry with Refurbished Historic Sign
- 2 Outdoor Table Tennis
- 3 Basketball Half Court
- 4 Custom Shade Structure
- 5 Outdoor Dining Area
- 6 Informal Nature Play
- 7 Primary Linear Pathway
- 8 Existing Mature Tree Species
- 9 Parkour Run
- 10 Large Custom Shade Structure
- 11 Flying Fox
- 12 Terrace Seating
- 13 Planting Islands
- 14 Drinking Fountain and Rubbish Bins



CLIENT

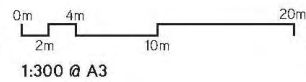

CONVIC

Unit 13, 46-50 Regent Street
Richmond VIC 3121
T (03) 9486 9899
Convic.com

PROJECT

Northam Youth Precinct

TITLE

Layout Plan - Youth Precinct Works

DATE

13.10.2017

REVISION

00

FINAL CONCEPT DESIGN

SKATE WORKS LEGEND

- 1 900H (3ft) Quarter Pipe
- 2 600H (3ft) Flat bank w/ Euro Gap
- 3 600H (3ft) Flat Bank w/ Hubba and Down Rails
- 4 1200H (4ft) Bank
- 5 900H (3ft) A-Frame with Rail
- 6 1200H (4ft) Quarter Pipe
- 7 600H Waterfall into Open Bowl
- 8 1800H Open Bowl
- 9 2000H (6.5ft) Extension with Granite Coping
- 10 1200H Quarter pipe

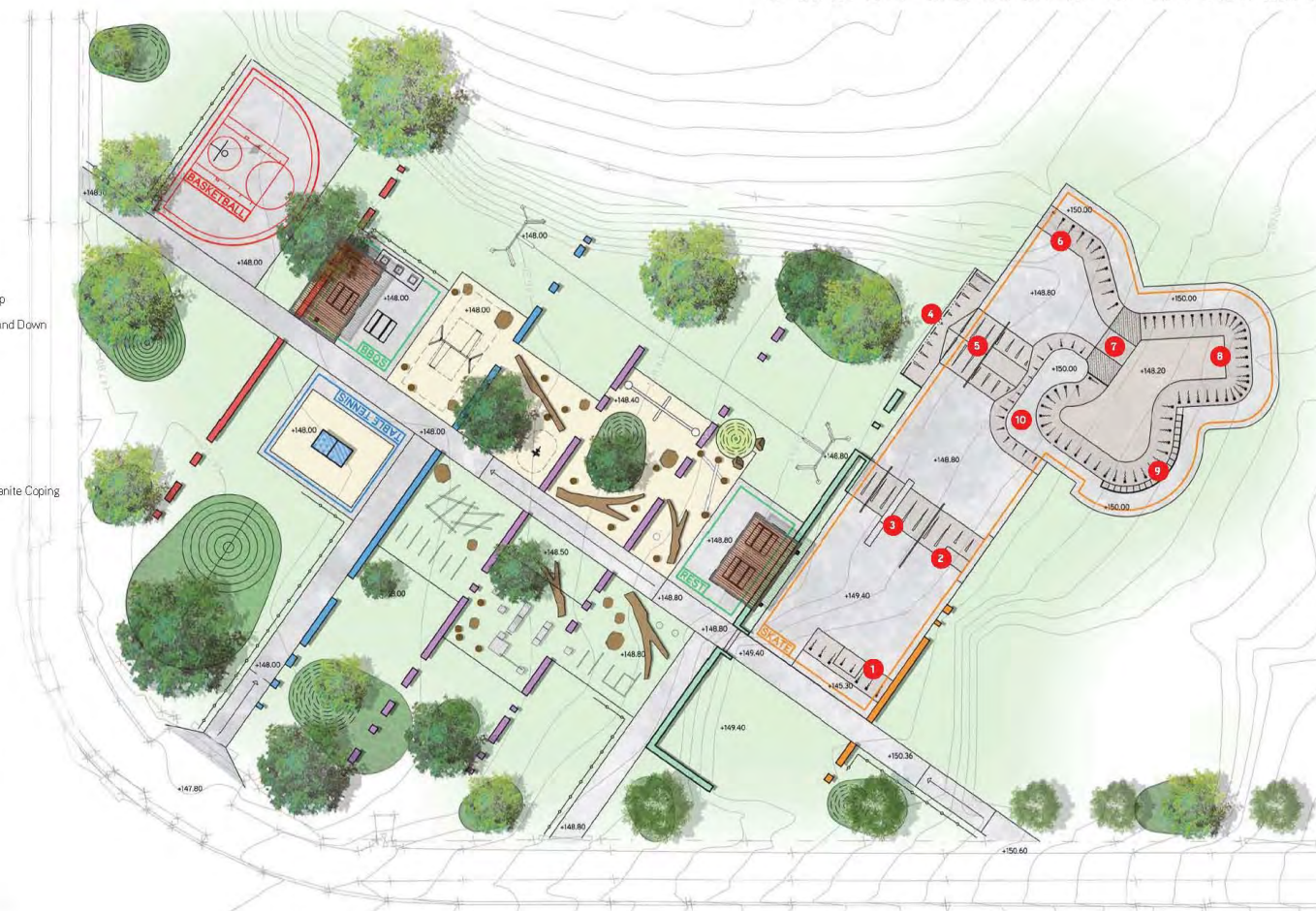

CLIENT

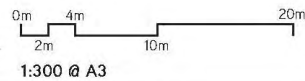

CONVIC

Unit 13, 46-50 Regent Street
Richmond VIC 3121
T (03) 9486 9899
Convic.com

PROJECT

Northern Youth Precinct

TITLE

Layout Plan - Skate Works

DATE

13.10.2017

REVISION

00

FINAL CONCEPT REPORT | NORTHAM YOUTH PRECINCT

27

Attachment 2



YOUTH PRECINCT LEGEND

- 1 Formal Entry with Refurbished Historic Sign
- 2 Outdoor Table Tennis
- 3 Basketball Half Court + Cinema Space
- 4 Custom Shade Structure
- 5 Lower BBQ & Picnic Area
- 6 Informal Nature Play
- 7 Parkour Area
- 8 Shade and Rest Area
- 9 Existing Mature Tree Species
- 10 Flying Fox
- 11 Drinking Fountain and Rubbish Bins
- 12 Terracing + Seating

SKATE WORKS LEGEND

- 1 Quarter Pipe
- 2 Flat Bank with Hubbas
- 3 China Bank
- 4 A-Frame Section
- 5 Quarter Pipe Return
- 6 Waterfall
- 7 Open Bowl
- 8 Bowl Extension

CLIENT

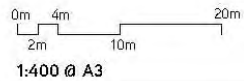

CONVIC

Unit 13, 46-50 Regent Street
Richmond VIC 3121
T. (03) 9486 9899
Convic.com

PROJECT

Northam Youth Precinct

TITLE

Draft Sketch Plan

DATE

21.09.2017

REVISION

00

NORTHAM YOUTH PRECINCT | DRAFT SKETCH DESIGN

Attachment 3



ACKNOWLEDGEMENTS

Convic Pty Ltd. Acknowledge the contributions of all those who participated in the consultation phase of the Northam Youth Precinct, including the Shire of Northam staff and residents, community groups and other stakeholders who responded to the various opportunities for input and/or who provided advice and information where required.

QUALITY INFORMATION

PROJECT NAME: Northam Youth Precinct
PROJECT NO.: 16078
PREPARED BY: Aidan Power
REVIEWED BY: Jason Geralis



PREPARED BY:

CONVIC

FOR:



REVISION HISTORY

REVISION	REVISION DATE	DETAILS	AUTHORISED	
			NAME / POSITION	SIGNATURE
A	23.08.17	DRAFT ISSUE	JASON GERALIS/ DESIGN MANAGER	
B	11.10.17	DRAFT ISSUE	JASON GERALIS/ DESIGN MANAGER	
C	13.10.17	FINAL ISSUE	JASON GERALIS/ DESIGN MANAGER	

WITH FUNDING PARTNERS:



© CONVIC Pty Ltd. All rights reserved.

CONVIC has prepared this document for the sole use of the Client and for a specific purpose, each as expressly stated in the document. No other party should rely on this document without the prior written consent of CONVIC. CONVIC undertakes no duty, nor accepts any responsibility, to any third party who may rely upon or use this document. This document has been prepared based on the Client's description of its requirements and CONVIC's experience, having regard to assumptions that CONVIC can reasonably be expected to make in accordance with sound professional principles. CONVIC may also have relied upon information provided by the Client and other third parties to prepare this document, some of which may not have been verified. Subject to the above conditions, this document may be transmitted, reproduced or disseminated only in its entirety.

CONTENTS

01 INTRODUCTION		07 DRAFT COMMUNITY CONSULTATION SUMMARY		13 PROJECT PHASING	
Executive Summary	04	Questionnaire Survey Results	19	Project Phasing Plan	37
Existing Skate Provision	05	08 LINK + RESOLVE IDEAS		14 DETAILED COSTING	
Understanding Skate Context	06	Draft Design Workshop Summary	23	Estimate of Probable Costs	38
02 JUBILEE RECREATION PRECINCT		09 DESIGN CONSIDERATIONS		15 MOVING FORWARD	
Understanding Site Context	07	Draft Community Consultation Design Considerations	24	Conclusion	39
03 SITE ANALYSIS		Further Design Considerations	25	Next Phase	39
Distance to Residents	08	10 FINAL CONCEPT DESIGN			
Surveillance	09	Layout Plan - Youth Precinct Works	26		
Connections	10	Layout Plan - Skate Works	27		
Vegetation	11	11 PERSPECTIVES			
Site Features	12	01. Overview	28		
04 PRE-DESIGN COMMUNITY CONSULTATION		02. Basketball + BBQ + Table Tennis	29		
Design Workshop + Key Outcomes	13	03. Adventure Play	30		
Community Inspired Design Vision	14	04. Street Section	31		
05 CONCEPTUAL DEVELOPMENT		05. Open Bowl	32		
Theming	15	12 PALETTES			
Conceptual Layers	16	Active, Passive and Temporal	33		
06 CONCEPT DESIGN		Skate Reference Images	34		
Draft Concept Design Plan	18	Furniture	35		
		Colour Palette	36		

01

INTRODUCTION

EXECUTIVE SUMMARY

The Shire of Northam is located within the Avon sub-region of the Western Australian (WA) wheat belt and has been nominated as one of the nine Super Towns in the southern half of WA. The Department of Regional Development and Land's Super Towns Vision is "to have a balanced, well-connected regional communities, with lifestyle options and access to services - Super Towns will have affordable, quality housing and a growing and diverse range of job opportunities. They will offer more choices for people living in regional areas and an attractive alternative to living in the metropolitan area".

Young people frequently leave Northam, seeking opportunities in metropolitan areas and the following report outlines the development of the Northam Youth Precinct (NYP) within the Jubilee Recreation Precinct site. This site was previously identified by Convic as the most preferred site for the location of the Northam Youth Precinct and was later approved by the Shire of Northam Council for further design investigations. A better understanding and knowledge of the youth community's needs and desires has been expanded through community consultation events, further developing community inspired briefs for the design and of the NYP.

The Northam Youth Precinct has been developed as a unique, iconic and site responsive multi-purpose, multi-generational facility that aims to complement the existing uses and recreational facilities of the Shire of Northam and broader wheat belt region. By utilising a holistic approach the design of the NYP will result in a dynamic and activated central community hub that offers recreational and social experiences for all members of the youth community, from day to day usage to larger community events.

The facility will become a key part of the youth space infrastructure within the Northam shire and greater wheat belt region forming a fundamental part of the Shire of Northam public realm strategy outlined within the Northam Regional Growth Plan (2012).

The following report explains the approach and principles utilised to create a comprehensive design response. It outlines the development of the design process and how it responds to council and community feedback. This builds a project vision and has resulted in a well informed final concept design.

The design explores opportunities and possibilities for the holistic integration of an active youth recreation precinct with environmental amenity, increased youth activation, supporting infrastructure, circulation and access.



VISION

**A STRATEGIC
APPROACH IN
'FILLING THE GAP'
IN PROVISION FOR
AN ACTIVE YOUTH
COMMUNITY FOR
THE SHIRE OF
NORTHAM AND
WIDER WHEAT BELT
REGION.**

SKATE FACILITY CONTEXT

EXISTING SKATE PROVISION

The skate and action wheel sport scene is highly activated and popular within the West Australian context. The WA midlands region however does not have the same number of well designed, high end facilities as elsewhere in the state resulting in a number of gaps within the regional skate provision.

While many youth facilities have a number of similar skate features due to their diversity in use, it is important to undertake a study of parks within the region of the proposed development. This further develops the typology of the proposed facility, while identifying where the gaps in skateable/rideable features are within the regional skate park network.

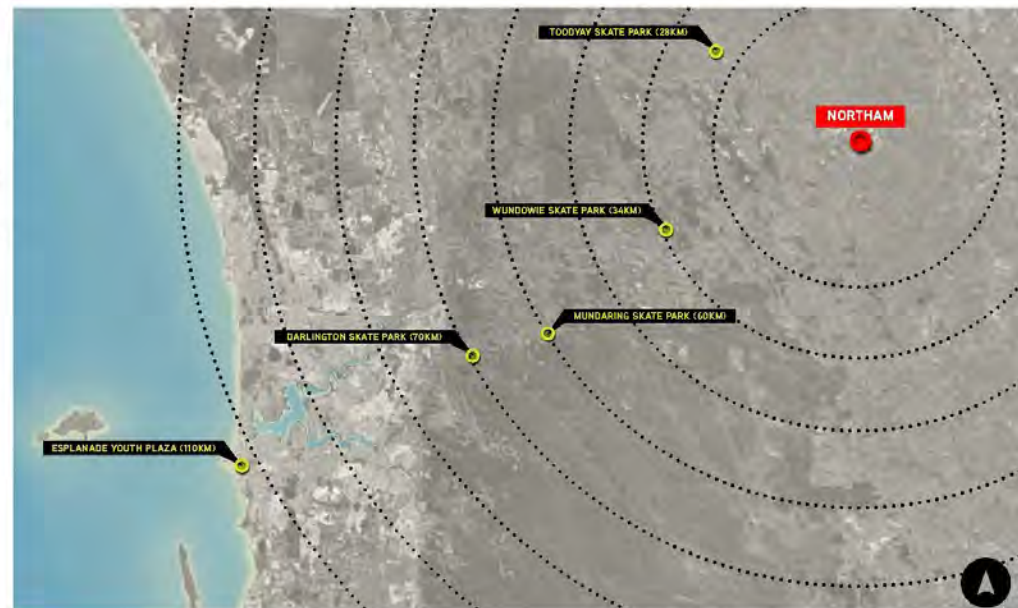

SKATE FACILITY CONTEXT

UNDERSTANDING SKATE CONTEXT

In addition to the proposed development of the NYP, there are a number of different accessible skate facilities within the midlands region of Western Australia. These parks include (in order of distance from Northam):

- Toodyay Skate Park - (28km NE) Catering to skaters and BMX riders the facility has a bowl with large extensions and a variety of street features including ledges, rails, hubbas and banks.
- Wundowie Skate Park - (34km SW) A refurbishment of an existing park catering to BMX and scooter riders, the extension offers hipped quarters and new street features for skaters.
- Mundaring Skate Park - (60km SW) A small back and fourth park with standard features including flat banks, quarters, rails and ledges.
- Darlington Skate Park - (70km SW) Predominately a street focused back and fourth skate park with mellow banks and quarters.
- Esplanade Youth Plaza - (110km SW) One of Australia's premier youth space's designed by Convic in a historical central location. The facility includes an competition capable bowl and a large street run consisting of rails, hubbas, banks, kickers and ledges. The facility also provides a number of other recreational activities including ping pong tables, a parkour and bouldering area and numerous social spaces and seating for families. Stage two proposes a half basketball court and BBQ facilities.



1. Toodyay Skate Park
2. Wundowie Skate Park
3. Mundaring Skate Park
4. Darlington Skate Park
5. Esplanade Youth Plaza - Street
6. Esplanade Youth Plaza - Parkour



02

JUBILEE RECREATION PRECINCT

UNDERSTANDING SITE CONTEXT

The location of the site designated for the NYP forms part of the Jubilee Recreation Precinct. The prospective site presents an opportunity for the Shire of Northam to develop a youth precinct in a vestige of unused space. Easily accessible by vehicle and public transport, the space is accessible to all demographics and provides the opportunity to lift the public profile of youth within the community.

Historically, the site has been used by the Agricultural Society as showgrounds for the Northam Show over a two day period in September of every year. The precinct provides adequate space to allow for the relocation of the show and its supporting infrastructure while the historic use of the site can be used to influence the design of the facility, forming links to its cultural heritage.

The redevelopment of the site will create a central hub for the young people of Northam, while further activating the Jubilee Recreation Precinct. Other activities within this precinct include BMX racing, traditional sports such as cricket, footy, netball and basketball, other indoor sports and the proposed relocation of the Northam swimming pool.

With the existing historic features and proposed development of the site, the facility will create a dynamic and activated central community hub to offer recreational and social experiences for all members of the community, from day to day usage to larger community events. As one of the foremost youth precincts within the area it will be a strategic public realm hub for Northam and its wider community.



03

SITE ANALYSIS

DISTANCE TO RESIDENTS

Youth facilities have the capability to be loud places due to the excitement and highly active users within the space. Generally from past experience, Convic has found that a 50m offset from the closest residential properties provides enough buffer for the noise to disperse.

Residential properties on the eastern side of Chidlow Street are within close proximity to the site and exploration into the placement of different activities on the site needs to be undertaken during the concept development phase to ensure the higher level of activity is not within the 50m offset.

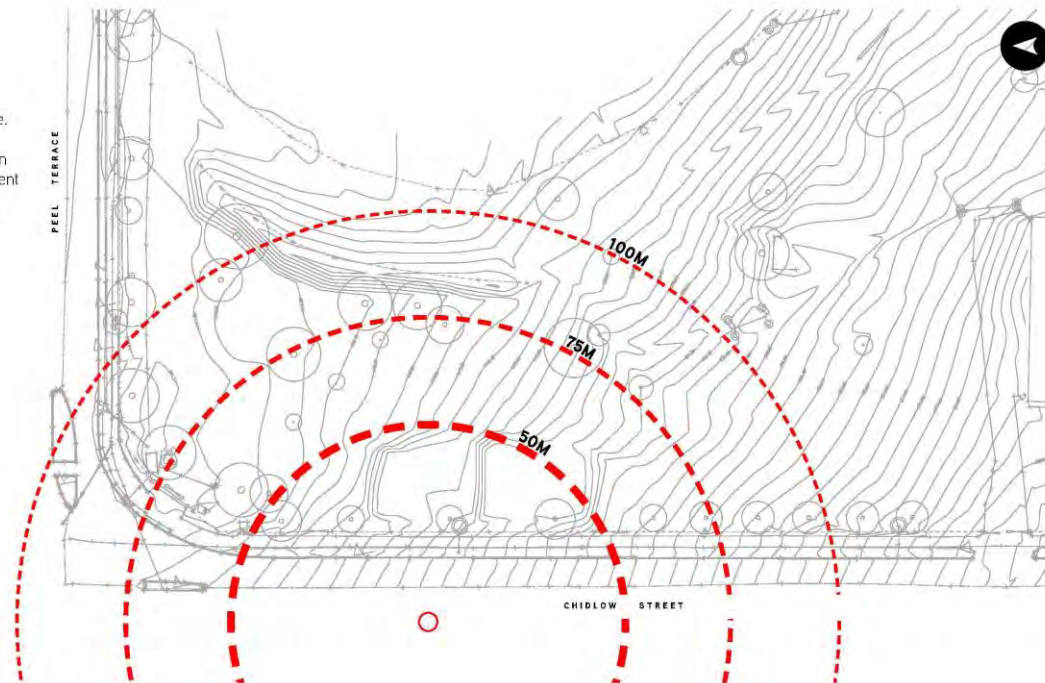

SITE ANALYSIS

SURVEILLANCE

It is essential for the design of any youth facility to allow for and encourage clear views into, across and through the site.

This will create passive and natural surveillance for the plaza and discourages anti-social behaviour. Due to the significant slope running in a south-north direction, there are a number of significant vantage points looking into the site from the southern end. These views are to be maintained and enhanced throughout the conceptual development phase.

A number of significant mature tree species are located on the lower, northern end of the site and consideration into canopy heights of these trees will be undertaken to maintain strong views through this area.

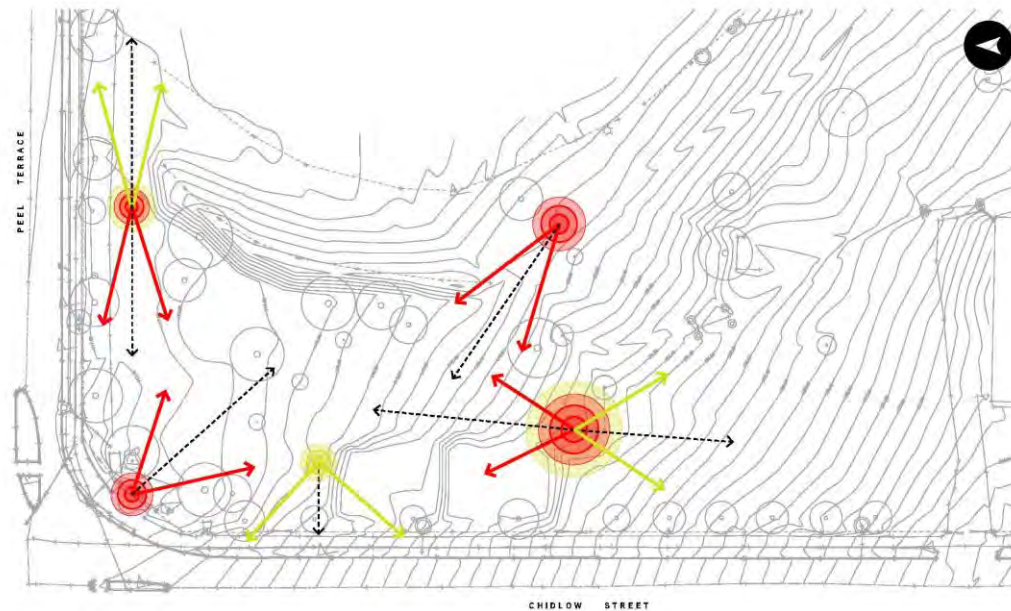
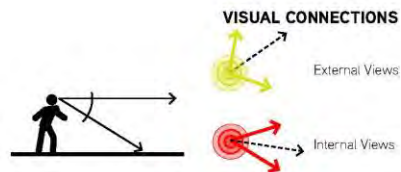

SITE ANALYSIS

CONNECTIONS

The location of the proposed facility will form a key part of Northam's recreational precinct.

Due to its proximity and connection to preexisting activities and a prominent corner location, the site will become an entry statement to the Jubilee Recreational Reserve forming a highly activated corner, lifting the profile of the youth community within Northam. There are a number of significant access points and several key entry nodes into the site. These are derived from the intersections of main pedestrian movements. These key circulation pathways through and around the site are considered when designing the space, form and functionality of the facility.

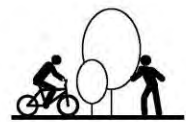

CIRCULATION

- Pedestrian Movement
- Pedestrian Desire Lines
- Vehicle Movement
- Seasonal Vehicle Access
- Primary Access Nodes

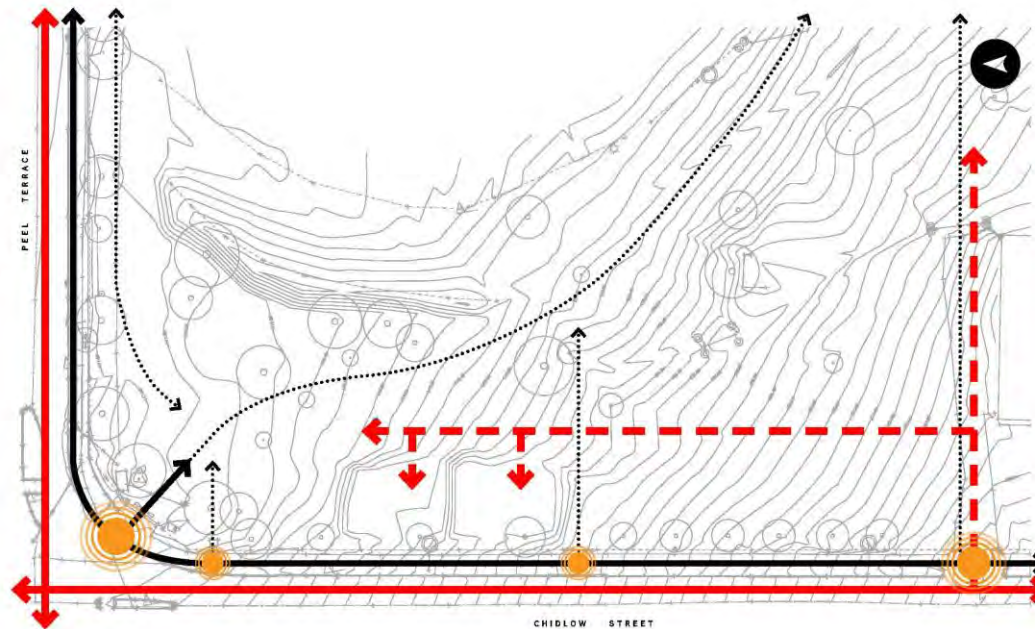

SITE ANALYSIS

VEGETATION

There are a number of significant existing mature tree species within the northern area of the site and along the Chidlow Street boundary. These trees provide a significant amount of shade to the site and will enhance the landscape character of the precinct.

Due to the climate within the Northam region it is proposed that all of the existing trees should remain on site to enhance shade provision within the facility and prolong use of the precinct through the hotter parts of the year.

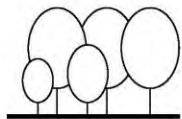

VEGETATION

 Existing Trees

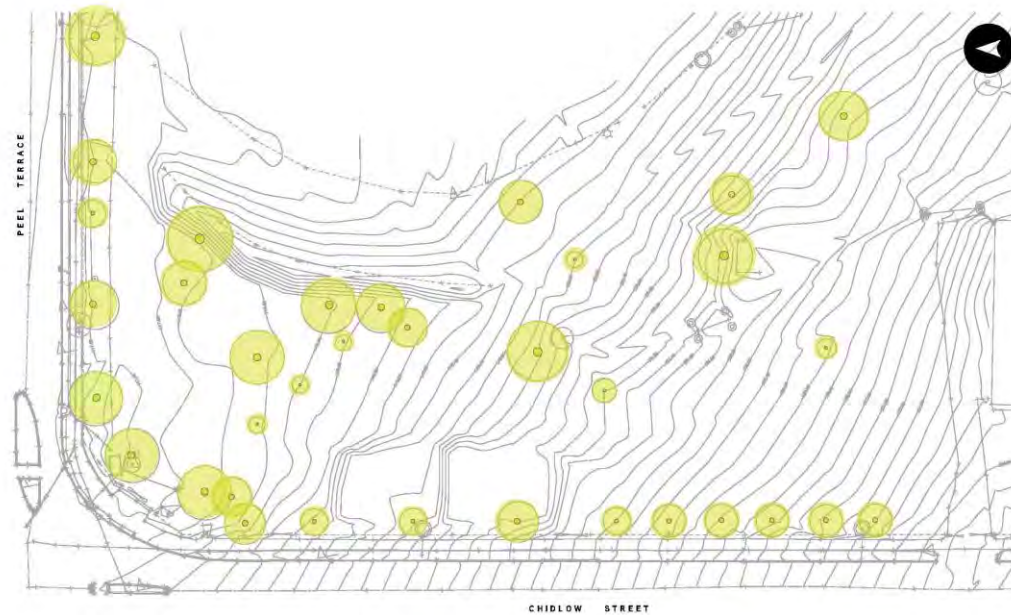

SITE ANALYSIS

SITE FEATURES

The Jubilee Recreation Reserve site has a number of existing conditions offering numerous opportunities and constraints. Some of these features have been considered, explored or utilised to inform the final concept design of the Northam Youth Precinct.

A number of these features form links to historic uses of the site and through engagement, research and celebration of these existing features the Northam Youth Precinct will develop a unique identity of the space without neglecting its past, present and future use.

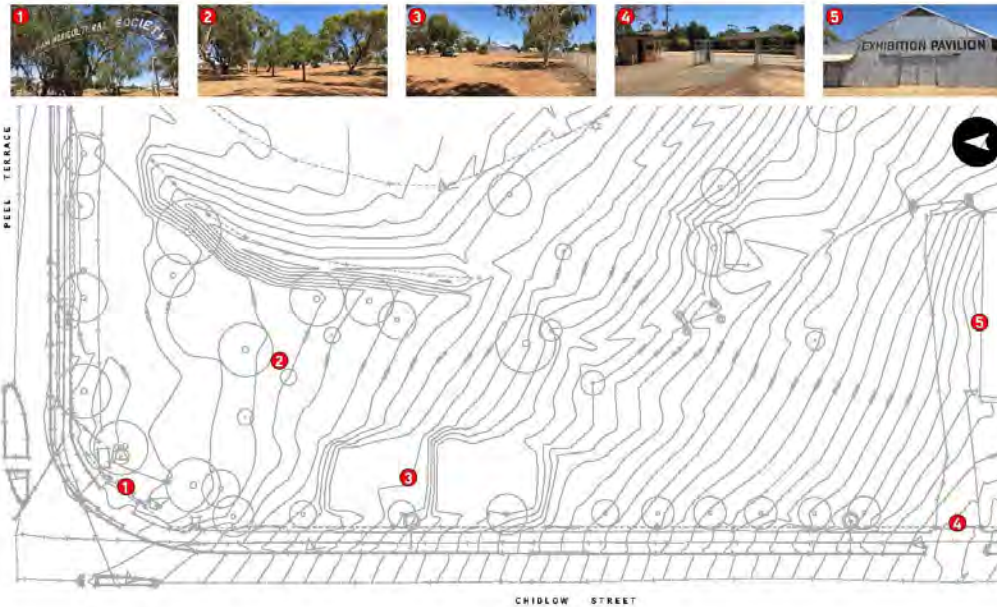

SITE FEATURES

- 1 Northam Agricultural Society Sign
- 2 Significant Mature Tree Species
- 3 Terracing
- 4 Vehicle Entry
- 5 Exhibition Pavilion

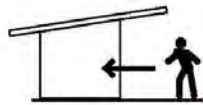

04

PRE- DESIGN COMMUNITY CONSULTATION

DESIGN WORKSHOP

During January of 2017 a number of design workshops were undertaken with the Northam community. These workshops are an essential and crucial component of the community consultation and engagement process. Participants have the opportunity to be an integral part of the design process and directly involved in creating ideas, and presenting them. The results of this build a community based response and develops a sense of value in their ideas, opinions and feedback that engenders ownership of the precinct.

Participants were organised into groups of 5 to 10 and asked to work collaboratively together to create their new Northam Youth Precinct. The aim was for participants to take inspiration from the features and activities outlined in the presentation and picture voting to develop creative design ideas and solutions by generating a space and linking features together to form a collective site responsive precinct. Each group consisted of a mix of participants from young people to more mature riders, parents and other community members. The mix in each group ensures a diversity and breadth of discussion, ideas and building of a general consensus.

The results saw an extensive range of creative and innovative responses, being written, drawn and using reference images. Each group nominated a representative to present their specific site plan / ideas and facility identity investigation, to the wider collection of people. After each group presented their ideas, the wider group discussed their favourite elements, summarising each presentation to form a detailed design brief.

KEY OUTCOMES

The following items are the key outcomes that were derived from the summaries of each of the groups creative design presentations:

SITE LOCATION

- Site 1 - Jubilee Recreation Precinct was the preferred location of all of the design workshop groups and was used to draw up their creative responses.

YOUTH PRECINCT FEATURES

- Drawing on inspiration from the existing exhibition pavilion to influence the design of unique features and wayfinding.
- Creating a circuit connection path around the facility and linking to existing precinct uses such as the BMX track, recreation centre and proposed swimming pool development.
- Including exercise equipment/pods on the peripheral circulation path. These should be at certain distances to encourage an exercise circuit like use of the path.
- Incorporating a multiuse space that could be activated through temporary outdoor cinema events with an elevated vantage point/stage.
- A network of shade structures ranging from large to small creating different types of social interactions.
- BBQ and family areas.
- Disability access around and through the site.
- Cultural spaces that allow for activation through art walls, theatre groups and other similar activities.
- Functional sports lighting until 10pm with pedestrian lighting after hours

SKATE FEATURES

- Using the sites unique topography to form a tiered approach to the skate park design
- Including a 6ft - 9ft deep bowl at the higher (southern) end of the site
- A split level street section including traditional features such as a small and large stair set, rails, ledges, hubbas, euro gap and banks.
- A wide BMX run (6m - to fit two people side by side) that could either include dirt jumps or concrete quarter pipes, moguls and a spine.
- A 5ft mini ramp at the lower (northern) end of the site.



PRE-DESIGN COMMUNITY CONSULTATION

DESIGN VISION

The key outcomes were summarised to inform a community inspired design brief. Information gathered from questionnaires, picture voting and design workshops, as well as conversations undertaken with users have shaped the brief. These have been used as the foundation for the bespoke development of the youth precinct draft concept design.

CLIMATE CONDITIONS

To increase the time the precinct is active through the day, the concept aims to provide opportunities for shelter and respite from the sun, particularly in the hotter months of the year. This is achieved through utilising and protecting existing mature tree species for natural shade and dedicated shade structures.

Throughout the consultation, participants demonstrated an interest in lighting the facility. Event lighting would assist in activating the space during the summer by avoiding the heat of the day as well as in the winter months.

LANDSCAPE INTEGRATION

The NYP site has an adjoining relationship with the existing uses of the Jubilee Recreation Precinct and its surroundings. Key items to address will be the entry points and connections to the existing BMX track, recreation centre and proposed swimming pool development.

The site is located on a prominent corner and the draft concept design resolution has considered these aspects of the site by providing adequate setbacks to areas of high speed and activity.

TARGET USER GROUP

The consultation feedback highlighted that the target age group utilising the facility will be between 11 and 20 years old. This group has expressed an interest in the precinct including a mixture of youth precinct activities and skating features. The majority of riders are skateboarders, however the inclusion of features to allow BMX and scooter riders have been considered within the draft concept design of the precinct.

YOUTH PRECINCT AMENITIES

To ensure a central community space that will be utilised by a broad spectrum of teenage users a number of youth activity features have been included within the design of the NYP. These features are a mix of multipurpose spaces for temporal activation events that provide comfort for users and spectators and offer opportunity for social interactions between different demographics to take place. As well as ongoing activation, safe equal access circulation around and through the site has been designed to allow for a number of different activities to take place including informal play areas, BBQs, family spaces, basketball and table tennis areas. The inclusion of safe segregated areas for younger kids, away from high speed zones, will enable the youth precinct to become a key community hub that will be enjoyed by different groups throughout the day.

SKILL LEVEL PROVISION

Community consultation feedback suggested many of the users were of a beginner to intermediate skill level. This has influenced the design through the inclusion of features that reflect these user skill levels. However, it is important that the facility caters for natural progression of skills and continual user challenge and development. A number of features within the design allow for more advanced riders to use the space and will form a unique mix in demographics within the space.

SKATE TYPOLOGY

The community consultation had an open platform for the skate typology. The results highlighted the need to cater for a mix of transition features that allow flow and speed as well as street and plaza style features. As a result of this an enclosed bowl and street section has been included within the design of the youth precinct.

05

CONCEPTUAL DEVELOPMENT

THEMEING

A common response through the community consultation referenced the historic use of the site. The Agricultural Society has used the site for many years showcasing a number of different local and regional agricultural practices, displays and events.

Northam is the centre of Western Australia's Avon wheat belt region with one of its key industry's being broad acre agriculture. This industry has a major influence on the landscape character of the area and has been explored throughout the conceptual development stages of the project to form connections between the micro and macro character of Northam.

The materials and signage associated with the Agricultural Society buildings, pavilions and infrastructure form a direct link to the agricultural use of the land in the wider Northam region. The reinterpretation of these materials within the design of the NYP will help to emphasize that link between the contemporary and the historic use of the site. The use of primary colours to differentiate each precinct will help to define each space and form a noninvasive wayfinding system. Extending the use of colour onto the existing mature trees and furniture palette will reinforce the playful, eye catching theme to encourage youth and families to enter the vibrant youth space.

The following pages build the conceptual layers based on this themeing.



CONCEPTUAL DEVELOPMENT

CONCEPTUAL LAYERS

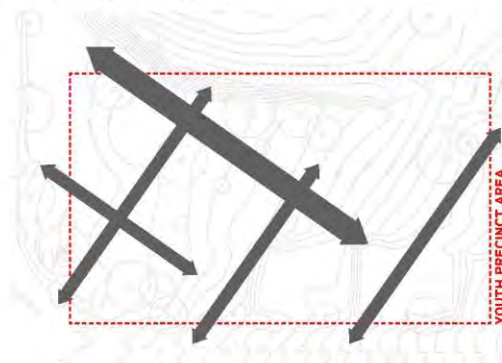

1. WHEAT FIELD ACCESS LANES

Access through the site has been designed to replicate access lanes within wheat fields for industry machinery to gain entry to the different wheat bays. These access lanes influence the way for users will move through the site and form areas of high back and forth activity.

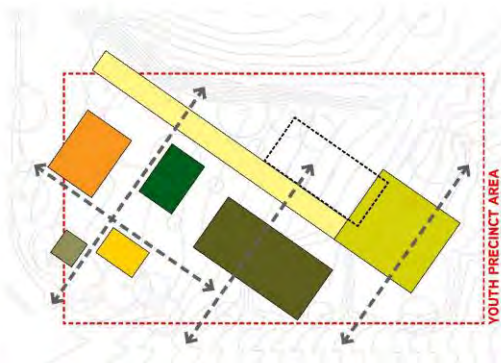

2. WHEAT FIELD BAY FORMATION

A number of different "bays" have been created along key access lanes/axis. These bays will start to influence and inform a program of passive and active recreation precincts and temporal or permanent activities within the site.

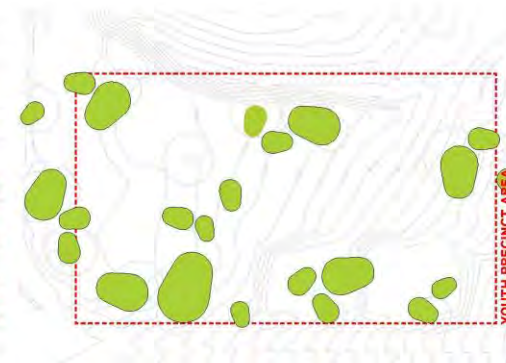

3. WHEAT HARVESTING

The harvesting, collection and storage of wheat within close proximity to the different bays influences the location of a diverse range mounded or sunken garden beds housing many of the existing mature tree species located within the site.

CONCEPTUAL DEVELOPMENT

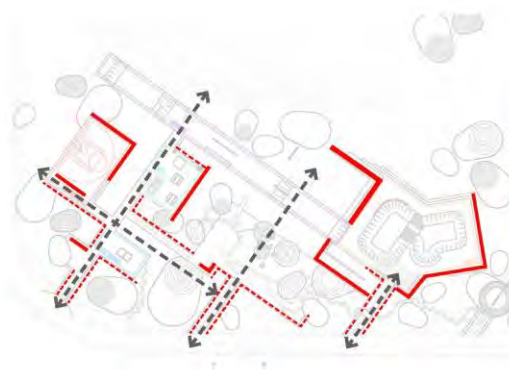

4. CONTROLLING THE ACCESS

The placement of fencing in key locations will control pedestrian access into, around and through the site replicating the use of simple fencing techniques used divide wheat field bays.

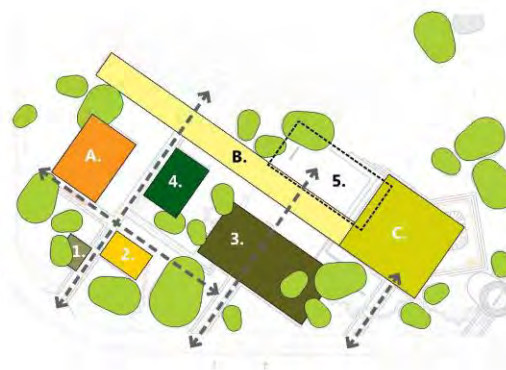

5. DEFINING THE BAYS

A number of different programs occur within the different bays. These bays are further defined and developed to form a network of active, passive and temporal programs to work together as an integrated network of activities.

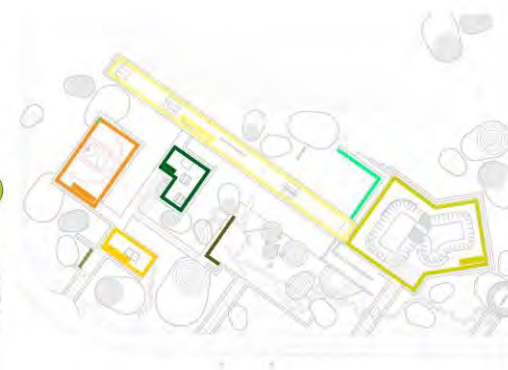

6. ARTWORK/WAYFINDING OVERLAY

A geometrical, bold and simple artwork and wayfinding strategy is overlaid within the different bays to form a connection with the historic uses of the site. The bold colours used within each precinct will form a visual wayfinding system across the site.

06

DRAFT CONCEPT DESIGN

YOUTH PRECINCT LEGEND

- 1 Formal Entry with Refurbished Historic Sign
- 2 Social Spaces
- 3 Outdoor Table Tennis
- 4 Basketball Half Court
- 5 Custom Shade Structure
- 6 Outdoor Dining Area
- 7 Informal Nature Play
- 8 Secondary Entrances
- 9 Existing Mature Tree Species
- 10 Flexible Activation Space
- 11 Large Custom Shade Structure
- 12 Informal Access
- 13 Flying Fox
- 14 Terrace Seating
- 15 Planting Islands
- 16 Drinking Fountain and Rubbish Bins

SKATE WORKS LEGEND

- 1 1200H (4ft) Shallow Section of Bowl
- 2 900H (3ft) Waterfall
- 3 2100H (7ft) Deep Section of Bowl
- 4 1500H (5ft) Taco Extension
- 5 2700H (9ft) Extension with Granite Coping
- 6 1500H (5ft) Quarter Pipe
- 7 500H Bank with Hubbas and Down Rail
- 8 450H Ledge
- 9 350H Flat Bar
- 10 500H Bank with Wuro Gap
- 11 1200H Return Quarter pipe



CLIENT

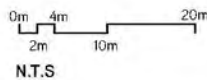

CONVIC

Unit 13, 46-50 Regent Street
Richmond VIC 3121
T (03) 9486 9899
Convic.com

PROJECT

Norham Youth Precinct

TITLE

Draft Concept Layout Plan

DATE

13.10.2017

REVISION

00

07

DRAFT COMMUNITY CONSULTATION SUMMARY

QUESTIONNAIRE SURVEY RESULTS

The following pages summarise the key results derived from the questionnaire undertaken by community members as part of the two NYP draft concept design workshops held at the Northam Recreation Centre on the 31st August 2017.

The concept design consultation process consisted of two community events. This approach ensured that the client, community, users and stakeholders were all provided with an opportunity to engage with the design process of the Northam Youth Precinct, ultimately helping to create a final design outcome that is in line with community aspirations and needs.

The Overall consultation process consisted of the following:

- Design presentation and workshop 1 - 31 August 2017 (4pm-6pm)
- Design presentation and workshop 2 - 31 August 2017 (6.30pm-8.30pm)

The results are an overview of the community profile of participants. Understanding the demographic patterns and trends within the community via the analysis of this data helps to inform the vision and typology of the proposed skate facility moving forward into the final concept design.

The following infographics represent the information collected through both hard copy questionnaires distributed during the consultation session.

The majority of responses were female aged 32+.

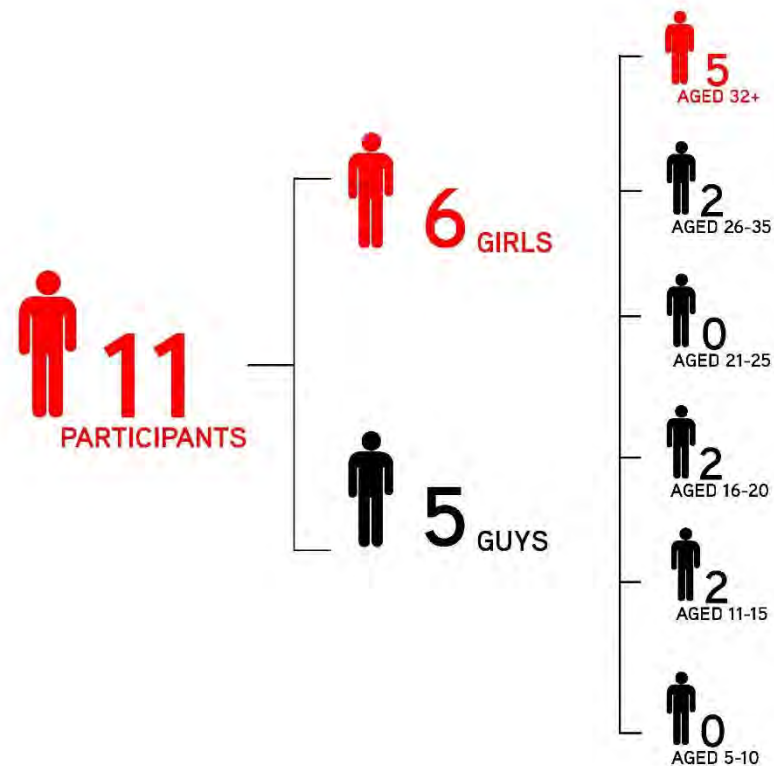

DRAFT COMMUNITY CONSULTATION SUMMARY

WHAT ACTIVITIES WILL YOU BE INVOLVED IN?

SUMMARY:

Different facilities may favour different user groups, highlighting the importance of determining which user groups will make use of the facility more frequently than others. This approach relates not only to the skateable areas but also the family and alternative recreation zones and areas present within the proposed NYP.

As an example, jumps and boxes more often appeal to scooter and BMX riders, whereas ledges, rails and bowls often appeal more so to skateboard riders. With this understanding, the questionnaire identified that the majority of respondents were skateboard and scooter riders. This indicates that the skateable area of the NYP will have to continue to cater for a mix of different users and appeal to riders of all disciplines.

A large number of participants identified themselves as spectators, parents and guardians, basketballers and table tennis players. This is important as it reiterates the need for these recreation areas within the NYP.

Moving forward further design direction and decisions will be made with the consideration of all of these user groups as to not exclude or leave out any user groups within the community who have had constant and ongoing input within the NYP design.

Note: Two participants identified themselves as youth workers in the other section of the questionnaire.

BMX



TOTAL: 1

INLINE

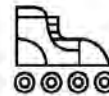

TOTAL: 1

SKATEBOARD

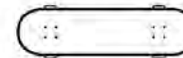

TOTAL: 3

NATURE PLAY



TOTAL: 1

SCOOTER



TOTAL: 2

TABLE TENNIS



TOTAL: 2

PARENT/GUARDIAN



TOTAL: 3

BASKETBALL



TOTAL: 3

SPECTATOR



TOTAL: 7

*Participants were allowed to vote more than once.

DRAFT COMMUNITY CONSULTATION SUMMARY

WHAT WOULD YOU SAY YOUR SKILL LEVEL IS?

SUMMARY:

The majority of participants indicated they are of a beginner skill level. The majority skill level will influence the design of features included within the park to ensure the overall design suits the ability of the user.

It is however key to provide for skill progression within any skate facility. This is to allow for beginner users and future generations to learn and continue ongoing progression up to an advanced skill level and for advanced users to continue to be challenged. This is achieved by providing a number of multi-purpose features and obstacles that have both beginner and advanced applications.

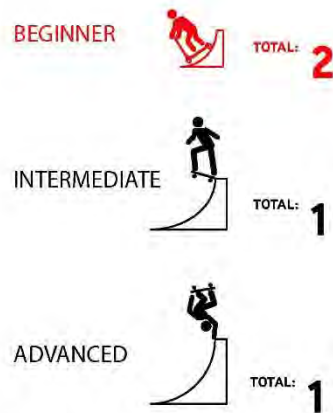

*Some participants did not answer this question.

WHICH IS YOUR FAVOURITE PART OF THE SKATE SPACE?

SUMMARY:

Participants were asked to nominate their favourite part of the NYP's skate space. The bowl area and street sections received the same number of votes, indicating that the NYP is to remain as a facility that caters to both street and transition style users.



*Participants were allowed to vote more than once.

WHICH IS YOUR FAVOURITE NON-SKATE FEATURE AND WHY?

SUMMARY:

Participants were asked to nominate their favourite non-skate feature. The family + social gathering areas and BBQ area received the highest number of votes, closely followed by table tennis, nature play and the open grassed areas. Many participants were happy with the design as a whole as they feel that it caters to a wide variety of user groups and ages.



*Participants were allowed to vote more than once.

DRAFT COMMUNITY CONSULTATION SUMMARY

WHAT'S MISSING?

SUMMARY:

Participants were asked to identify what they felt was missing from the NYP concept design. Results varied from WIFI ports for users to connect to the internet, a soccer goal, a disabled access swing and a skateable china bank.



*Participants were allowed to vote more than once.

ANY OTHER COMMENTS?

SUMMARY:

Further comments on the NYP concept design were limited and included the suggestion of the future installation of toilet facilities and a subsequent access path to them, as currently users of the facility in need of a rest room would have to leave the NYP and cross the road to the McDonalds restaurant.

Another suggestion was to include fruit trees within the design, this could in turn create community garden type area(s) within the NYP. This could inspire further community garden areas and groups within the NYP where workshops could be held. The collaboration of multiple age groups from youth to grandparents within these areas would create a strong gardening community within the NYP and Northam as a whole.

QUESTIONNAIRE RESULTS SUMMARY

In summary comments made on the draft concept design of the Northam Youth Precinct were positive. Community members who participated in the Northam Youth Precincts draft concept design questionnaire seemed happy with the direction in which the precinct was heading, noting that it will become a key social and active hub within the heart of their community. The importance of retaining a design that caters to multiple user groups and ages was reiterated through comments received from the community at both the consultation and through the questionnaires.

Notable and popular comments made on the concept design to be considered in the design of the NYP moving forward include; Including WIFI facilities within the park, so that users are able to go online whilst within the area, this may be used by youth within the skate zones uploading videos of themselves and others or throughout other areas of the facility for music or educational videos. Other suggestions included; the installation of a soccer goal and kick about space somewhere within the precinct and the inclusion of a disabled access swing if possible.

Comments on the skate area of the precinct were positive, with an equal number of participants identifying that they are in favour of both the street and transition style features within the facility. This indicates that the precinct is to maintain both a transition and street style focus moving forward. A feature which was requested by a number of questionnaire participants was a skateable china bank.

Moving forward these results will be compiled with the results from the workshop sessions (Section 06) and will be considered in the development of the final concept design of the NYP.

08

LINK + RESOLVE IDEAS

DRAFT DESIGN WORKSHOP SUMMARY

The design workshop is an essential component of the community consultation and engagement process. At this point, participants are immersed in the consultation process and directly involved in creating ideas and presenting them. This builds a community based response to the process and develops a sense of value in their ideas, opinions and feedback that engenders ownership of the process.

Participants were asked to collaborate and work together to make comment and adjustments were they felt necessary to the NYP draft concept design. The aim was for participants to take inspiration from items and features discussed earlier in the workshop and develop creative design ideas and solutions that work with their new developmental suggestions for the precinct.

The design workshop comprised of a mix of participants from young people to more mature riders, parents and other community members. By ensuring the different groups had a mix of demographics within them creates a diversity and breadth of discussion and ideas.

The results saw an extensive range of creative and innovative responses, whether written, drawn or using reference images, regarding not only the skate space layout but also the additional community based elements for the precinct. The outcomes from each of the two design workshop groups have been summarised in the following section. These will be compiled with the results from the questionnaires to inform a brief for the development of the final design of the NYP.



DESIGN WORKSHOP GROUP 1:

- 9 attendees (mostly councillors or stakeholders) – no skaters
- Inclusion of Wi-Fi into the design is needed. Needs to be allocated in the costing.
- GPOs and USBs added to shade structures and should be allowed for in costing.
- Half nature play could be converted to smaller amount of parkour/modex frames
- Flying fox goes through two trees with magpie nests. Prefer to see the flying foxes side by side so can race. Look into reducing 40m down to 25m to free up some cash for above items.
- Informal carparking will occur at the upper end of the site. Access from this area into the side needs to be considered. Moving flying foxes to open up the connection.
- Possibility of having a basketball hoop with a soccer goal post underneath. How does that work with road behind it? Higher fence?
- Extensive drainage will be needed. Might need to bump up the allowance in the costing
- Possibly remove proposed fences and concrete under table tennis table if more money needed.



DESIGN WORKSHOP GROUP 2:

- 2 attendees – 1x skater and 1x BMX
- Possible to include a 10 stair set next to quarter coming down from bowl platform. (split quarter in half)
- 500H round downrail
- Cut flat section to 8m in length between the quarter and hubba/rail/bank combo.
- 350H square flat bar
- Possibly include curved bank around flat bar as alternative route when its busy
- 200H step in euro
- Concave ledge instead of flat ledge?
- Possibly remove proposed fences and concrete under table tennis table if more money needed.

09

DESIGN CONSIDERATIONS

DRAFT COMMUNITY CONSULTATION DESIGN CONSIDERATIONS

The following design elements have been created in response to the findings as part of the draft concept design community workshop sessions and survey. These design elements will drive the design changes to the Northam Youth Precinct to create a design that is reflective of not just the sites context, site conditions, but also the communities aspirations and local insight.

CLIMATE CONDITIONS

To increase the time the precinct is active through the day, the concept will continue to provide opportunities for shelter and respite from the sun, particularly in the hotter months of the year. This will be achieved through utilising and protecting existing mature tree species for natural shade and dedicated shade structures. Many participants identified that they were in favour of this green approach and that retaining the existing trees was a cost effective and aesthetically pleasing way to provide shade for users.

LANDSCAPE INTEGRATION

The NYP site has an adjoining relationship with the existing uses of the surrounding recreation precinct. Key items to continue to consider moving forward, will be the entry points and connections to the existing BMX track, recreation centre and proposed swimming pool development. It has also been identified that informal car parking will be included at the sites western end, consideration of how the car park will interact and connect with the precinct is to be taken and will become an important factor in design decisions/changes made moving forward.

Participants were in favour of the theming idea used to help to integrate the design into the surrounding landscape and character of Northam. They appreciated the wheat industry theme and subsequent artwork and positioning of the amenities and zones to represent this. When the annual Northam Show is on at the bordering sports oval, the NYP will reflect this, becoming an integral part of experience for all

involved.

TARGET USER GROUP

Currently the design of the NYP caters to all skate user types and disciplines. The majority of participants at the draft concept consultation identified themselves as skateboarders and scooter riders, moving forward any changes made to the NYP concept design will continue to consider other disciplines such as BMX and inline in the final concept design.

YOUTH PRECINCT AMENITIES

Many of the participants were happy with the youth precinct amenities present within the NYP design. Suggestions for the development of the layout and or design of these spaces included; to relocate the flying fox that runs parallel with the skate street section to a closer location, this is due to locals identifying that it currently runs through the centre of two large trees which contain magpie nests. The magpies have been known to attack passers by and it was suggested that the flying foxes run parallel with one another so that users are able to race.

A number of participants suggested the installation of a soccer goal somewhere within the precinct. It was suggested to possibly install a basketball hoop which had a soccer goal at its base, this will require design consideration in relation to the installation of a higher fence or planting behind this area to prevent the ball from landing on the road behind.

It was suggested that a section of the nature play area contain some parkour or modex style features to cater to an active community user group not yet addressed by the NYP. The installed parkour or modex features would cater to mostly users of a beginner level, which would also allow users of the nature play areas to utilise them, as to not reduce the size of their area too much. It is however important to provide some advanced level features within this area to cater to users of different levels and encourage skill and trick progression from beginner to advanced users.

Power points and WIFI are becoming popular features within youth precincts across the globe. The installation of such features was requested frequently by many consultation participants and is to be considered in the final concept design of the NYP.

A disabled access swing was also suggested and would be suitably located within the nature play area within the design, the installation of a disabled swing would in turn result in the installation of a swing set as to cater to all youth within the region.

SKILL LEVEL PROVISION

Participants identified themselves as being of varying skill levels, this means that moving forward the design of the NYP is to continue to cater to users of all skill levels. It is important that the facility caters for natural progression of skills and continual user challenge and development for all users and disciplines.

SKATE TYPOLOGY

Participants identified that they were equally in favour of both the transition and street sections of the NYP concept design. This means moving forward it is important to retain a design which caters to both styles of riding.

Participants provided input into what they felt should change or be considered within the final NYP design, suggestions for skate features included; a china bank, 10 stair, a 500h down rail, a 350h flat bar, a curved bank around the flat bar as an alternative route when it's busy, a 200h euro gap and a concave ledge instead of a flat ledge.

DESIGN CONSIDERATIONS

FURTHER DESIGN CONSIDERATIONS

During our review of the NYP Draft Concept Design we identified that the precinct was predominantly on budget with the exclusion of landscape works. These landscape works are integral in creating the full intended experience of the NYP design. In order to ensure that the design was providing the most it could for the community within the indicated budget, a further more comprehensive review of the design was undertaken.

This required investigating the design to identify areas where improvements could be made, to allow for both the precinct activities and landscaping to be constructed within the one budget. Some of the proposed changes are as follows:

- We found that the large bowl and the orientation of the long linear street section were not working with the sites existing landscape conditions and were therefore consuming a large portion of the allocated budget for the NYP through the need of additional concrete terracing, landscaping works and earth fill. Through relocation and re-orientation of the entire skate area to the southern end of the park, the skate area now runs alongside the existing slope of the site, providing a flatter area for the skate park and the requirement for less earthworks and large scale terracing, freeing more funds for other activities within the precinct.
- The bowl was identified as being too large and advanced for the local community. A new bowl has been designed which is less advanced and works more effectively with the sites existing conditions, reducing the need for extensive terracing. The open bowl design combines both the street and transition sections of the skate park into one area, which improves the capacity, functionality and use of the park. The revised layout also better caters for a variety of rider (skate, BMX, Scooter) and promotes greater skill progression which would suits beginner, intermediate and advanced level users.

- The inclusion of a bold linear pathway that cuts through the centre of the site connecting Chidlow St E and Peel Terrace has been proposed. This creates a strong pedestrian connection within the precinct, connecting the previously disconnected northern and southern ends of the facility and also creates a "backbone" to the facility of which all amenities, activities and areas can be accessed. A future access pathway to the proposed carpark can be easily connected onto this 'backbone' at its southern end, creating an easily accessible and functional space from all immediate surrounding areas.

- The theming of wheat harvesting was well received by the community and this has been retained through the development of the design. The natural grade of the slope up towards its southern boundary has meant that the site requires a number of terraces to create flat functional spaces within the precinct. The idea of landscape terracing and low walls has been continued along the entire length of the primary pathway through the site. Running perpendicular to the primary path the low walls divide up activities and disciplines into zones and enclosed areas.

With these adjustments, along with adjustments made following the community's feedback on the Draft Concept Design the revised Northam Youth Design is now more aligned with its indicated budget as now landscape works are included within the design. The design has been altered to reflect the feedback gathered through the community consultation and now functions and works with the existing site in a more natural, cost effective and creative way.

10

FINAL CONCEPT DESIGN

YOUTH PRECINCT LEGEND

- 1 Formal Entry with Refurbished Historic Sign
- 2 Outdoor Table Tennis
- 3 Basketball Half Court
- 4 Custom Shade Structure
- 5 Outdoor Dining Area
- 6 Informal Nature Play
- 7 Primary Linear Pathway
- 8 Existing Mature Tree Species
- 9 Parkour Run
- 10 Large Custom Shade Structure
- 11 Flying Fox
- 12 Terrace Seating
- 13 Planting Islands
- 14 Drinking Fountain and Rubbish Bins

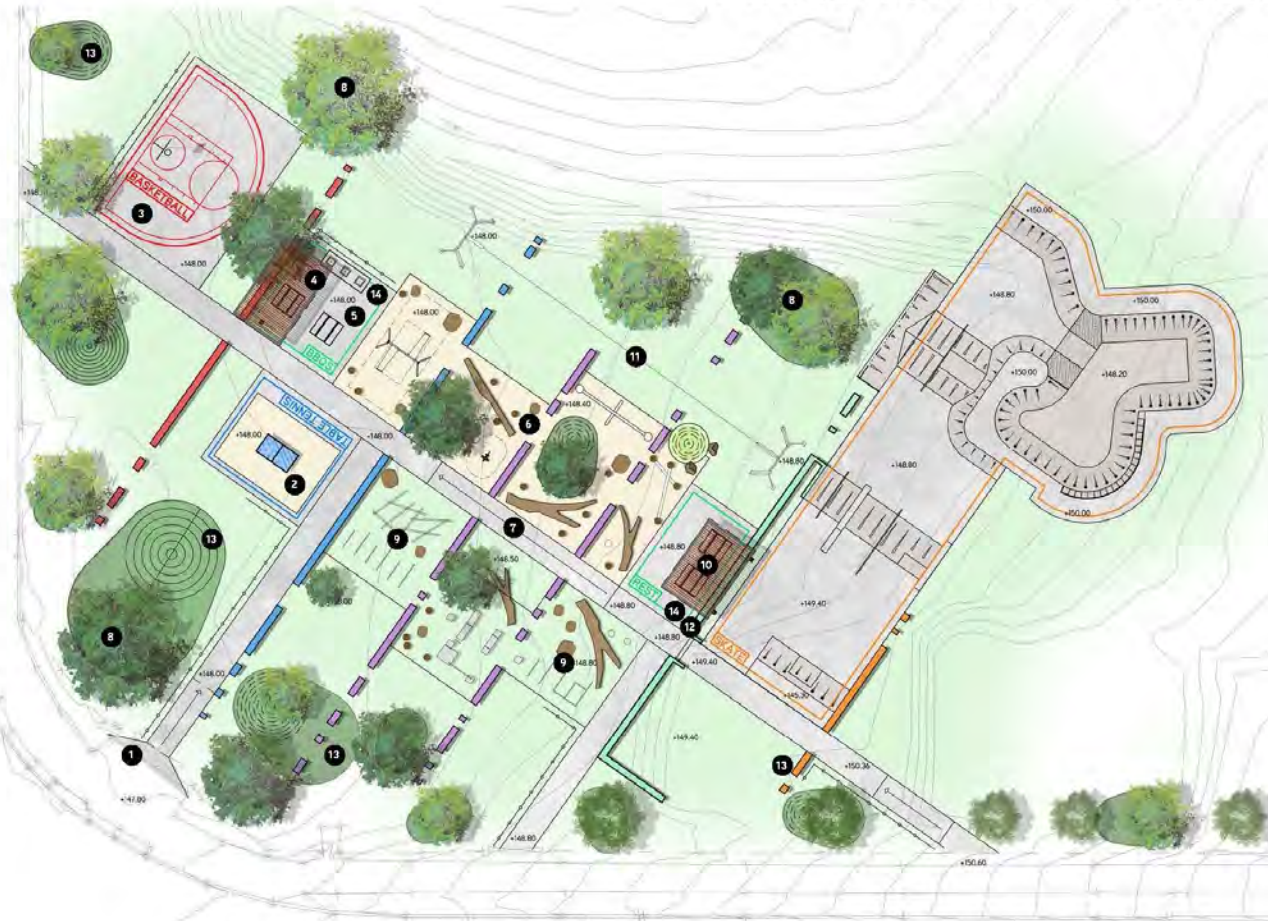

CLIENT

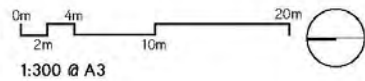

CONVIC

Unit 13, 46-50 Regent Street
Richmond VIC 3121
T (03) 9486 9899
Convic.com

PROJECT
Northam Youth Precinct

TITLE
Layout Plan - Youth Precinct Works

DATE
13.10.2017

REVISION
00

FINAL CONCEPT REPORT | NORTHAM YOUTH PRECINCT

FINAL CONCEPT DESIGN

SKATE WORKS LEGEND

- 1 900H (3ft) Quarter Pipe
- 2 600H (3ft) Flat bank w/ Euro Gap
- 3 600H (3ft) Flat Bank w/ Hubba and Down Rails
- 4 1200H (4ft) Bank
- 5 900H (3ft) A-Frame with Rail
- 6 1200H (4ft) Quarter Pipe
- 7 600H Waterfall into Open Bowl
- 8 1800H Open Bowl
- 9 2000H (6.5ft) Extension with Granite Coping
- 10 1200H Quarter pipe

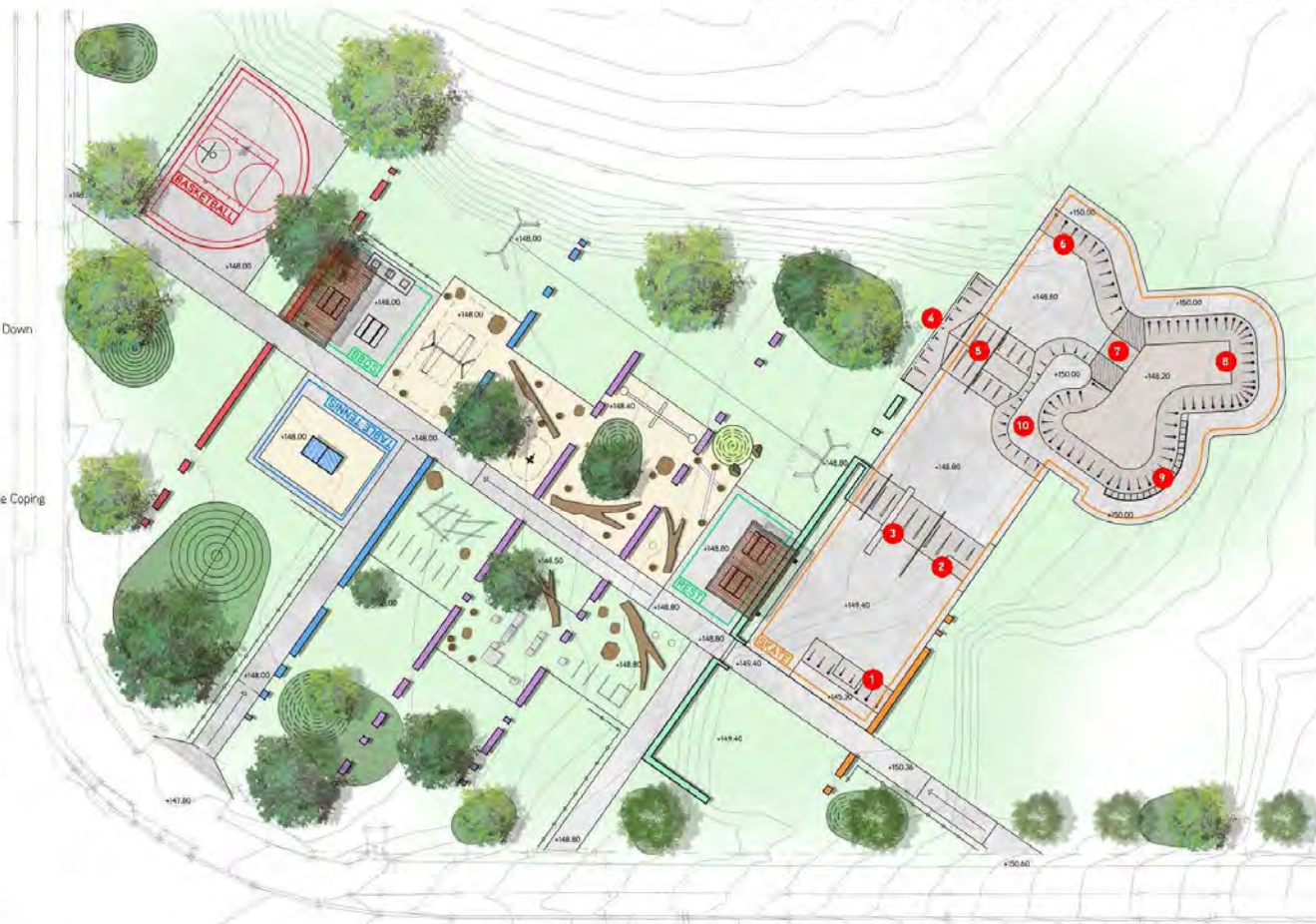

CLIENT

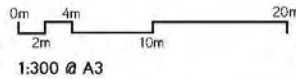

FINAL CONCEPT REPORT | NORTHAM YOUTH PRECINCT



Unit 13, 46-50 Regent Street
Richmond VIC 3121
T (03) 9486 9899
Convic.com

PROJECT
Northam Youth Precinct

TITLE
Layout Plan - Skate Works

DATE
13.10.2017

REVISION
00

11

PERSPECTIVES

01. OVERVIEW











12

PALETTES

ACTIVE, PASSIVE AND TEMPORAL

A number of different activities have been included within the design of the Northam Youth Precinct. These activities provide an opportunity for different types of users to interact and share one space. These activities include:

1. Outdoor ping pong
2. Informal nature play
3. Basketball
4. Hangout spaces
5. Shady green retreat
6. BBQ areas



PALETTES

SKATE REFERENCE IMAGES

Skate obstacles have been designed to create a unique rider experience with features that are multifunctional and can be used in a variety of ways. Features will allow for skill progression within users while maintaining the ability to be used by a number of different riders.

1. Bank around street features - Mona Vale Skate Park
2. Level changes in street area - Mona Vale Skate Park
3. Waterfall into open bowl - St Kilda Skate Park
4. Skill Progression features - Mona Vale Skate Park



PALETTES

FURNITURE

Furniture elements within the Northam Youth Precinct will compliment the individual precincts and allow for the design of the space to uniquely connect with the character of the community and historic uses of the site.

1. Concrete terraces
2. Drinking fountain
3. Signage
4. Functional lighting
5. Shade shelter
6. Fencing



PALETTES

COLOUR PALETTE

The colour palette has drawn inspiration and been selected from natural materials within the Northam and greater wheat belt region. These colours compliment the portland grey concrete colour and will create a hardscape that seamlessly integrates into its surrounding environment.

In a juxtaposition to the natural concrete colours, bold and vibrant colours have been selected to delineate each precinct of activity occurring within the Northam youth precinct. These colours have been inspired by the historic signage that occurs on nearby agricultural show infrastructure and will mirror the high level of activity occurring at the precinct.



CCS BRAZIL NUT
Grey Cement



CCS POMPEII ASH
Grey Cement



CCS DROVERS DUST
Grey Cement



CCS PORTLAND GREY
Grey Cement



**TABLE
TENNIS**

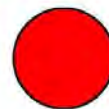

BASKETBALL



**BBQS +
REST**



PLAY



SKATE

13

PROJECT PHASING

PROJECT PHASING LEGEND

-  PHASE 01
-  PHASE 02

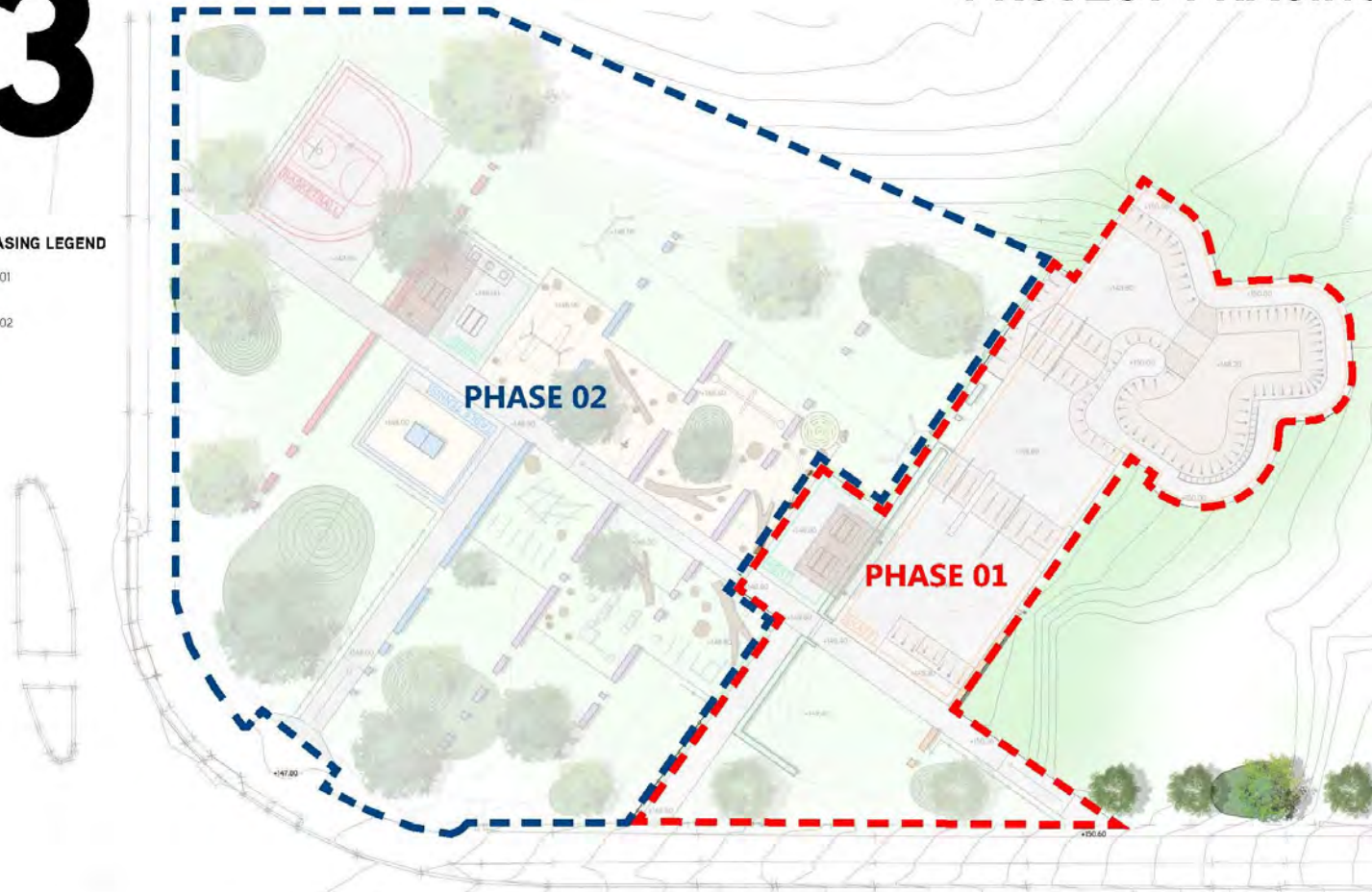

CLIENT

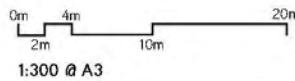

FINAL CONCEPT REPORT | NORTHAM YOUTH PRECINCT

CONVIC

Unit 13, 46-50 Regent Street
Richmond VIC 3121
T (03) 9486 9899
Convic.com

PROJECT
Northam Youth Precinct

TITLE
Layout Plan - Project Phasing

DATE
13.10.2017

REVISION
00

37

14

DETAILED COSTING

ESTIMATE OF PROBABLE COST		
13.10.17 SO_REV B		PREPARED: AB CHECKED: JT
PROJECT NAME: 16078_WA_Northam Youth Precinct <small>Based on Final Concept Report issued 11.10.17</small>		
ITEM	DESCRIPTION	PROBABLE COST
1.0 PRELIMINARY WORKS		
1.1	Preliminaries Including insurances, mobilisation, site establishment, project management, travel, demobilisation, accommodation, lifts and all site establishment costs.	\$ 90,000.00
1.2	Earthworks Including excavation, site scrape, filling, grading & finishing, sub-base preparation and compaction to achieve design levels.	\$ 51,000.00
SUB TOTAL		\$ 141,000.00
2.0 SKATE PARK WORKS		
2.1	New Skate Park Supply and setting of all steel reinforcement; supply and setting of formwork; supply and placement of skate and landscape concrete; specialised finishing, curing, sealing, clean up and patching.	\$ 624,000.00
2.2	Granite Coping Supply and install of custom honed granite coping to corner of bowl.	\$ 7,000.00
2.3	Metaworks Including supply, fabrication and install of all custom skate steel works including coping and rails.	\$ 20,000.00
SUB TOTAL		\$ 651,000.00
3.0 HARD LANDSCAPE		
3.1	Pavements Supply and installation of pedestrian pathways.	\$ 65,000.00
3.2	Retaining Walls Supply and installation of retaining walls.	\$ 23,000.00
SUB TOTAL		\$ 88,000.00
4.0 SOFT LANDSCAPE		
4.1	Garden Beds Supply and installation of garden bed areas, including topsoil and planting.	\$ 41,000.00
4.2	Turfed Areas Supply and installation of seeded grass to areas surrounding skate park and community areas.	\$ 29,000.00
4.3	Irrigation Supply and installation of irrigation system to cater to soft landscape areas.	\$ 71,000.00
4.4	Schallal Supply and installation of 300mm deep schallal to nature play area, table tennis table, and flying fox lay zones.	\$ 9,000.00
SUB TOTAL		\$ 150,000.00

5.0 FURNITURE ITEMS		
5.1	Signage Fabrication supply and installation of vandal resistant laser cut safety steel sign and footings and custom lettering to heritage sign.	\$ 17,000.00
5.2	Shade Fabricate, supply and install 2 no. custom shade shelter and associated footings.	\$ 71,000.00
5.3	BBO Supply and installation of electric BBO, including all electrical works.	\$ 14,000.00
5.4	Basketball Court Supply and installation of basketball ring and line marking.	\$ 4,000.00
5.5	Table Tennis Supply and installation of steel table tennis table, including all associated concrete footings.	\$ 14,000.00
5.6	Picnic Tables Supply and installation of 4 no. picnic tables, including all associated concrete footings.	\$ 40,000.00
5.7	Drinking Fountains Supply and installation of 2 no. drinking fountains, including all associated plumbing, and concrete footings.	\$ 20,000.00
5.8	Rubbish Bin Enclosures Supply and installation of 2 no. double rubbish bin enclosures, including all associated concrete footings.	\$ 10,000.00
5.9	Nature Play Supply and installation of nature play elements including timber logs, stepping stones, timber balance poles and small rope play feature.	\$ 71,000.00
5.10	Double Flying Fox Supply and installation of 2no. 40m long flying fox play features.	\$ 60,000.00
5.11	Fencing Supply and installation of fencing to replicate design fencing at key entry points and areas of pedestrian congregation.	\$ 8,000.00
5.12	Parkour Supply and installation of all concrete blocks and metal framework in parkour zone.	\$ 29,000.00
5.13	Line-marking Including supply of all materials, and labour, for application of line-marking detail on concrete surfaces.	\$ 21,000.00
SUB TOTAL		\$ 379,000.00
6.0 ELECTRICAL ITEMS		
6.1	Lighting and Electrical Design, supply and installation of light columns, footing, flood lights, trenching, cabling and power outlets.	\$ 143,000.00
SUB TOTAL		\$ 143,000.00
TOTAL OF WORKS		\$ 1,552,000.00

Excludes
- GST
- Authority charges
- Cost escalation
- Sitegrade improvement works

Note - This estimate is based on currently available industry prices. State/per construction is a specialised trade and costs are prone to fluctuation.

Costs have been based on recently tendered projects. This is an estimate of budget costs only, all components are subject to community consultation, design and accurate costings. Cost can vary greatly dependent on complexity of design and features included.

15

NORTHAM YOUTH PRECINCT: A STRATEGICAL APPROACH IN 'FILLING THE GAP' OF YOUTH FACILITY PROVISION FOR THE SHIRE OF NORTHAM AND WIDER WHEAT BELT REGION.

CONCLUSION

The Final NYP Concept Design draws influence from the historic agricultural uses of the NYP site and reflects Northam's unique landscape character and large active involvement in wheat production within WA. These dominant themeing ideas have helped to shape both the spatial layout, material palette, colour and overall atmosphere of the NYP Final Concept Design.

The NYP has been developed as a multi-use, multi-generational facility, providing a range of activities and areas for all members of the Northam community, including: a large street skate area and open bowl, Table Tennis, Basketball, Adventure Play, Parkour, BBQ and rest areas and open shaded green retreats. These elements have all been connected through a distinct, bold, primary pathway which cuts through the centre of the NYP site. This pathway provides controlled and free flowing pedestrian movement through the precinct and ensures a seamless street connection and legible circulation with natural and passive surveillance across, into and through the entire site.

The location and design of the precinct will integrate seamlessly into the existing amenities available and the proposed future works of the Jubilee Recreation Precinct. The incorporation of public open spaces, shelters, refuge and BBQ areas will compliment and ultimately become a part of the annual Northam Agricultural Show.

The continued involvement and engagement of the community throughout the design process ensured the evolution of a highly site responsive and resolved final design outcome that is unique to the Northam community. This engenders community pride and ownership in both the process and the public facility, creating a strong sense of stewardship of the NYP and a vested interest in the final constructed precinct.

This broad and holistic approach ensures that the NYP will become a key community asset that caters to a wide variety of users and age groups, ultimately bridging the gap in youth facility provision for the Shire of Northam and wider wheat belt region.

MOVING FORWARD

NEXT PHASE

The Final NYP Design will be submitted to the Shire of Northam council for final approval and adoption in October 2017. This review is to ensure the design reflects community needs, user requirements, council objectives and the project vision.

Upon endorsement of the design it is recommended that the Shire should advertise the Final Concept Design within the community as a "for information only". This will allow the community to view the results of their involvement within the design and consultation process.

Convic will progress through the design development stages of the design process, developing the design in more detail with a focus on levels, site drainage, DDA access, skate feature development and budgeting.

Following the design development stages CONVIC will prepare a construction documentation package of the approved NYP Design.

The construction of Stage 01 of the NYP is planned to begin mid 2018, with the remainder of the Precinct (Stage 02) beginning construction once the sufficient funds have been gathered through the relevant funding bodies.

CONVIC
CREATE COMMUNITY

UNIT 13, 46-50 REGENT STREET
RICHMOND VIC 3121 AUSTRALIA
T +61 3 9486 9699 F +61 3 9486 9088
CONVIC.COM

Attachment 4

Shire of Northam Local Planning Scheme No.6 Northam Youth Precinct (Reserve 217) 44 Peel Terrace Northam WA 6401 Schedule of Submissions				
Number	Name	Summary of Submission	Key Themes Identified in Submission	Officers Comment
1	Northam Agricultural Society	Page (map 02) reads Unused space. It is not unused space. Paragraph states HAS BEEN used but it is constantly in use by kids on bikes and campers, used frequently for overnight camping, parking for major events, Agricultural Show market and general stall holders and food vendors space as well as public parking, Caravan Park registered overflow area, dog walkers, sports event parking, natural play area (not man made).	<i>Current Usage of Space</i>	<p>The area identified as unused due to it not being identifiable with ongoing activity. The area does get used periodically for overflow parking for major events and is utilised by the Agricultural Society 2 days per year. As with all events, officers will work with event organisers on parking plans for major large events, including the Agricultural Show, on an as needs basis.</p> <p>It is not regularly used as a caravan overflow area. The previous overflow camping area (National Balloon Championships 2017) was located at Bert Hawke Oval.</p>
		Will proposed area be levelled flat, or terraced on various stages due to the present lay of the land.		It is proposed that the development will fit the current lay of the land.
		This area has been known for many, many years by local residents as Billy Goat Flats due to its history of flooding. It	<i>Flooding</i>	The designers were made aware of this and it has been taken into consideration

Shire of Northam Local Planning Scheme No.6
Northam Youth Precinct (Reserve 217) 44 Peel Terrace Northam WA 6401
Schedule of Submissions

Number	Name	Summary of Submission	Key Themes Identified in Submission	Officers Comment
		was historically deemed unsuitable for anything other than stock grazing or open space. This area still floods very frequently as Yilgarn Avenue and the Railway line create a natural dam area. There are already many drainage issues around the Town of Northam that have been attempted to be resolved unsuccessfully - will this be the same.		
		Lighting - lights should be solar powered with back up. This venue will need to be lit all night, for security. There is already a known drug problem and vandalism in this area on a frequent basis and this will only continue if the area is not adequately lit.	<i>Lighting</i>	Lighting will be considered as part of the finished facility.
		Who is to be responsible for daily cleaning of the proposed area. With the risk of syringes and drug equipment left lying around, this will be a big risk for youth. The rubbish bins will need to be emptied daily due to the proximity of nearby fast food outlets. Will this become another littered point.	<i>Cleaning</i>	This will be covered as with all Council facilities with regular inspection to ensure safety and cleanliness. As with all new facilities, consideration of adequate rubbish bins will be part of the concept for this facility.
		What Public Liability is in place to cover this area? Does it cover the unwanted	<i>Insurance</i>	As with all Council facilities, Council's public liability insurance will provide coverage.

Shire of Northam Local Planning Scheme No.6
Northam Youth Precinct (Reserve 217) 44 Peel Terrace Northam WA 6401
Schedule of Submissions

Number	Name	Summary of Submission	Key Themes Identified in Submission	Officers Comment
		loiterers and drug users. Who pays for this?		Any issues of anti-social or illegal behaviour should be dealt with assistance from WA Police.
		There is no access to Public Toilets 24 hours a day. The closest Public Toilets are at Bernard Park, it is not fair for Fast Food Chain and Service Station to have to cover this aspect.	<i>Toilets</i>	It is not designed as a 24 hour facility.
		Will the Proposed Youth Precinct be adequately fenced? There is a major road and railway within metres of this area? Will the Proposed Youth Precinct for internally fenced? For major events where general public pay to enter the grounds, how will those using the Youth Precinct be monitored? EG - Vintage Swap Meet and Northam Agricultural Show.	<i>Fencing</i>	There is currently adequate fencing around the Jubilee Recreation Precinct. In respect to major events where entry fees are charged, access to the Youth Precinct may be restricted.
		This proposal does not highlight any safety aspects, access for emergency service vehicles, muster points, etc. This area is known to be very hit and miss with mobile phone reception -will an emergency phone be placed with in the zone.	<i>Emergency Situations</i>	All aspects of safety, emergency access will be addressed during construction. It is felt that there is adequate access for emergency vehicles to the site, via access from Chidlow St, or if required via Peel Terrace.

Shire of Northam Local Planning Scheme No.6
Northam Youth Precinct (Reserve 217) 44 Peel Terrace Northam WA 6401
Schedule of Submissions

Number	Name	Summary of Submission	Key Themes Identified in Submission	Officers Comment
		Are Northam Recreation Centre Staff to be included in the cleaning and safety of this area? Have they been advised to possible changes to their job descriptions?	<i>Northam Rec Centre Staff</i>	This is not a consideration
		What provisions have been made as an alternative Caravan Park Overflow site including the provision of powered sites. Already there is no Public amenities on the ground that are open 24/7.	<i>Overflow Camping</i>	This Area is used infrequently as an overflow Caravan parking site. The previous overflow caravan site was located at Bert Hawke Oval. See (Point 1 above).
		What alternative provisions have been made for the parking for major events - the Balloon Fiesta had this area completely full, as does the Northam Agricultural Show, the Vintage Swap Meet and other events. If we are to encourage major Football games in Northam this area will be required for parking! Isn't that why the new Henry Street oval has had so much work done?	<i>Parking</i>	As with all major events, a parking plan will be put in place for the individual event, in discussion with the organisers. Officers will have discussions with the Agricultural Society as required to deal with this issue.
		What alternative do people who live in the immediate area have as a provision for Dog walking if this area goes? Many people walk their dogs in the shade of the trees rather than the ovals.	<i>Walking Dogs</i>	This proposal will not be fenced off, and does not preclude dog walkers.

Shire of Northam Local Planning Scheme No.6
Northam Youth Precinct (Reserve 217) 44 Peel Terrace Northam WA 6401
Schedule of Submissions

Number	Name	Summary of Submission	Key Themes Identified in Submission	Officers Comment
		Noise problem - Map 03 Site Analysis shows a semicircle only of the noise effected area. This will extend through to Duke Street residents also. Have all residents been duly informed?	Noise	This will not create any more noise than other major events at this facility (e.g. Ag Show, major sporting events, concerts) A community engagement process was undertaken, including 2 rounds of community workshops, and a community survey, which were advertised to the entire community.
		One week between receiving the proposal and the submission needing to be returned is a tiny amount of time for people to respond to this. People are busy and mail service isn't daily, there is not enough public awareness, this should be in the newspapers, and a lot easier to look at on the Shire Website. It takes a very long time to find it unless you use the web site daily and understand the Shires navigation tools.	Submission Time	Letters to surrounding landowners were posted on the 10 th November with a closing date for submissions on 27 th November 2017 as per normal procedures.
		Placing the Youth Precinct in this location greatly depletes us of our use of this space during the Northam Agricultural Show. We use this area for Food Vendors, Market Stalls and General exhibitors as	Northam Show	Council officers are happy to engage with event organisers, including the Ag Society, on site planning for major events.

Shire of Northam Local Planning Scheme No.6
Northam Youth Precinct (Reserve 217) 44 Peel Terrace Northam WA 6401
Schedule of Submissions

Number	Name	Summary of Submission	Key Themes Identified in Submission	Officers Comment
		well as Public parking and ACROD parking.		
		Limited access of vehicle movement. This appears to leave a single lane width between the Northam Agricultural Society Pavilion and the top edge of the Skate park, without any security fence provisions. During Show time there are large semi-trailers, emergency service vehicles and security as well as general public that need to drive through this area. Having traffic forced closer to the Pavilion increases the risk of accidents, especially with pedestrians using this area at the same time. If this is to be single lane, where is the proposed exit to be?	<i>Vehicle Access</i>	As per page 12, the existing entrance off Chidlow St has been considered in the design, as have Significant tree species, terracing, the historic sign and the Exhibition pavilion.
		The Agricultural Society require a Minimum of 50 Metres from the Pavilion to allow for vehicle movement, display options and ACROD parking.	<i>Parking</i>	See point 16
		The power boxes that a 3 phase power that are in the proposed area were installed and paid for through the Northam Agricultural Society. If these are to go, will the Shire provide us with multiple generators (as neighbouring Shires do) for the running of our Show?	<i>Power</i>	This will need to be discussed with the Agricultural Society. The Power boxes are currently maintained by the Shire.

Shire of Northam Local Planning Scheme No.6 Northam Youth Precinct (Reserve 217) 44 Peel Terrace Northam WA 6401 Schedule of Submissions				
Number	Name	Summary of Submission	Key Themes Identified in Submission	Officers Comment
		Also we the Northam Agricultural Society be financially remunerated for the cost of installation of the power boxes as loss of infrastructure?		
		The Youth Precinct will need to be adequately fenced off from the remainder of the grounds as the Northam Agricultural Show is a paid event to enter. Already there are ongoing problems with holes in the existing fencing where people can walk in and climb over the fence to avoid paying an entry fee.	<i>Fencing</i>	See point 8
		The Shire have removed many existing toilets from the Grounds over the years, as a result portable toilets are used and some are placed with in this area for public access, otherwise public have to walk to the Recreation Centre for toilets, and they are locked outside of office hours.	<i>Toilets</i>	The location of temporary toilets for major events can be discussed with event organisers on an as needed basis. See also point 7 above
		Who will control the rubbish removal, removal of dangerous drug equipment and provide security in this area?	<i>Cleaning</i>	See point 5 above. Also, CCTV will be planned as part of the final project
		It is our belief that due to Yilgarn Avenue being a part of the National Highway Route that there is to be no vehicular or pedestrian access through the	<i>Agricultural Society Historical Archway</i>	There is already a pedestrian gate located there. It is not intended for vehicular traffic access.

Shire of Northam Local Planning Scheme No.6
Northam Youth Precinct (Reserve 217) 44 Peel Terrace Northam WA 6401
Schedule of Submissions

Number	Name	Summary of Submission	Key Themes Identified in Submission	Officers Comment
		Agricultural Society Historical Archway. This was brought to our attention many years ago by Main Roads and their laws, thus this is why that gate remains closed. Is it the Shires intention to have this gate open to traffic and pedestrians, what safety will be placed?		
		The Agricultural Society Archway is Heritage listed and is an important part of Northam's history. What measures have you in place to maintain the sign, does the Northam Agricultural Society have final say in this?	<i>Heritage</i>	The historic sign has been incorporated in the design. See maps 06 and 10 reference to Formal entry with refurbished historic sign.
		Map reference 02 - paragraph 2 states - The precinct provide adequate space to allow the relocation of the Show and it's supporting infrastructure while the historic use of the site can be used to influence the design of the facility, forming links to its cultural heritage. What is the intended meaning of Relocation of the Show and its supporting infrastructure?	<i>Relocation of Show</i>	This refers to being able to plan the Ag Show activities, and their location around the youth precinct.
2	Heather Meiklem	The plans show that the NYP extends right up to the front of the Northam Show Pavilion with a roadway separating the two. The Northam Show runs for two days on the second weekend in September,	<i>Parking and Show Exhibitors</i>	See previous comments re parking. Officers are happy to work with any major event organisers to ensure that all needs can be met.

Shire of Northam Local Planning Scheme No.6
Northam Youth Precinct (Reserve 217) 44 Peel Terrace Northam WA 6401
Schedule of Submissions

Number	Name	Summary of Submission	Key Themes Identified in Submission	Officers Comment
		<p>however the preparation of show exhibits, etc. take the full week or more before the event. The area planned for the NYP normally provides vital parking for general public over the show plus some of the area is used for business exhibits. Exhibitors for the Pavilion and Poultry Section require a huge area for easy dropping off of exhibits prior to the Show. Of this is made too difficult for the exhibitors then they may stop supporting the Show.</p>		
		<p>The Jubilee Gate at the corner of Chidlow Street and Avon terrace has a special historical significance to Northam. There is mention in the Shire of Northam plans for the refurbishment of the gate. Please ensure that this refurbishment is done in consultation with Northam Agricultural Society, Northam & Districts Historical Society and even the Northam Heritage Forum. Northam cannot lose another of its historical artefacts.</p>	<p><i>History</i></p>	<p>It has been considered an integral part of the precinct design. All relevant stakeholders will be consulted.</p>
		<p>Unfortunately the area is already prone to illicit drug use. The Northam Agricultural Society committee are</p>	<p><i>Security</i></p>	<p>CCTV is being considered for this area, and police are also aware</p>

Shire of Northam Local Planning Scheme No.6
Northam Youth Precinct (Reserve 217) 44 Peel Terrace Northam WA 6401
Schedule of Submissions

Number	Name	Summary of Submission	Key Themes Identified in Submission	Officers Comment
		<p>regularly requesting the removal of syringes from the area. The area is used by squatters who presumably engage in drug taking. Removal of drug taking instrument, condoms and clothing is done on a regular basis by volunteers. The premises in Animal Nursery and Shed have resulted in vandalism and break-ins. Rock throwing by local youth at any of the buildings spread throughout the Recreation area is an on-going problem. The complete Recreation area does receive unsociable behaviour and this needs to be monitored regularly by Police and Shire.</p> <p>The NYP layout will encourage families to come and enjoy the area which will allow for adult supervision for the younger children. I anticipate that there will be surveillance by the local police for the area. Would the Shire of Northam consider putting the area under camera surveillance to ensure ongoing safety for the NYP users and respect for the property?</p>		<p>of, and supportive of, the development in this area. It is anticipated that increased activity in the area, and increased scrutiny, will reduce the amount of antisocial behaviour as the area becomes activated.</p>
		<p>The NYP is open to general public according to the plan. General public</p>	<p>Access to NYP during</p>	<p>As above re restricted access during major events. Officers</p>

Shire of Northam Local Planning Scheme No.6
Northam Youth Precinct (Reserve 217) 44 Peel Terrace Northam WA 6401
Schedule of Submissions

Number	Name	Summary of Submission	Key Themes Identified in Submission	Officers Comment
		<p>access during the Northam Show will be only by entry to the Show, unless the youth jump the fence which is already an ongoing problem with inadequate fencing at other points around the Show Ground complex.</p> <p>The NYP concept mentions that this area will be of benefit to the Show. Is it anticipated that Show patrons may want a place to sit or is there a suggestion that the NAS hold an exhibition of skate boarding during the Show. Funding for this could be forthcoming from the Shore of Northam to the Northam Agricultural Society. It should be noted that surrounding Shires support the Agricultural Shows with amazing sponsorship and support. NAS does receive funding from Shire of Northam.</p>	<p><i>the Northam Show</i></p>	<p>also believe that this facility can be another element to the show, with skating exhibitions and comps to attract participants.</p> <p>The Shire of Northam does support with both direct and indirect funding and significant in kind assistance.</p>
		<p>The present plan is for the users of the NYP to cross Chidlow Street and use toilets at either McDonalds or the Dunnings Roadhouse. My concerns are for the traffic and pedestrian safety in this area. Could consideration be given to build toilets over the area that originally had</p>	<p><i>Toilets</i></p>	<p>Public toilet facilities will be considered in future planning of the precinct.</p>

Shire of Northam Local Planning Scheme No.6
Northam Youth Precinct (Reserve 217) 44 Peel Terrace Northam WA 6401
Schedule of Submissions

Number	Name	Summary of Submission	Key Themes Identified in Submission	Officers Comment
		the toilet block as all the below ground structure would already be there.		
		Please be aware that the existing buildings could certainly do with upgrades to blend in better with the new \$1.5million plus NYP, rather than be overshadowed.	<i>Other Facilities</i>	Noted
		The colour palette is a good one recognising the historic usage of this area for the Northam Show and Federals Football Club. I would strongly suggest that you include the colours of the Railways Football Club unless that is represented by the purple and orange.	<i>Colour Palette</i>	Noted for consideration
		I do support the overall concept of the Northam Youth Precinct but request that the Shire of Northam support other users of the Jubilee Recreation/Show Grounds with the same respect and support.	<i>Other Users of the Space</i>	The shire provides significant support to all users of the precinct, either by direct or indirect funding, or in kind support.
3	Geoff Carruthers	Accept, as long as the Police are prepared to patrol and move along trouble makers.	<i>Police Presence</i>	The police are aware of, and supportive of this facility. A combination of police, active and passive surveillance will assist in reducing or preventing anti-social behaviour.

12.3.3 Request to Vary Local Planning Policy 23 – Lot 125 Wilson Street, Grass Valley

Address:	Lot 125 (64) Wilson St, Grass Valley
Owner:	Mr S Murray
File Reference:	A15765 / P17090
Reporting Officer:	Jacky Jurmann Planning Consultant
Responsible Officer:	Chadd Hunt Executive Manager Development Services
Voting Requirement	Simple Majority

BRIEF

A development application has been received to obtain approval to construct an outbuilding at Lot 125 (64) Wilson Street, Grass Valley.

The property is zoned Residential R10 under the provisions of the Northam Local Planning Scheme No. 6 and is currently vacant.

The application is referred to Council as the proposal is inconsistent with the provisions of the Shire of Northam Local Planning Policy No 23 – Outbuildings in the Residential and Mixed Use Zones.

ATTACHMENTS

Attachment 1: Locality Plan.

Attachment 2: Site Plan and Outbuilding Plans.

BACKGROUND / DETAILS

Lot 125 (64) Wilson Street, Grass Valley has an area of 1201m² and is located in the townsite of Grass Valley.

Water, power and telecommunications infrastructure service the property, however there is no deep sewerage available. Therefore, any future dwelling will need to be serviced by an approved on-site sewerage management system, which due to the size of the lot, would be an alternative treatment unit.

The proposed outbuilding will be located at the rear of the lot and will be 83m² in area. The wall height is 2.5m, an overall height of 2.6m and be constructed of eco cladding/panelling that will be in the colour of Colourbond Surfmist. It is proposed to install solar panels on the roof of the shed.

The Applicant, in support of his application, has provided the following information:

"I request permission that I be able to construct a shed on the block at 64 Wilson Street, Grass Valley before my house is built to provide interim storage for my vehicles and assortment of tools.

I am waiting for the sale of my freehold property at 16 Tait Close, Bakers Hill so I can use the funds to finish the project I have in place at Wilson Street."

An overall site plan has been provided (refer to Attachment 2) depicting the location of the future dwelling.

CONSIDERATIONS

Strategic Community / Corporate Business Plan

Theme Area 1: Economic Growth.

Outcome 1.1: The Shire of Northam is an attractive investment destination for a variety of economic sectors.

- Ensure the Shire of Northam is a welcoming and easy place for quality investment to occur.

Financial / Resource Implications

There are no direct financial and/or resource implications for the Shire in relation to the recommendations of this report.

Legislative Compliance

Northam Local Planning Scheme No. 6

The subject property is zoned Residential R10. Single dwellings are a permitted use in the zone, including ancillary development, such as outbuildings and swimming pools, subject to compliance with the R-Codes.

Clause 4.22 of LPS6 sets out the provisions relating to the construction of outbuildings:

- 4.22.1 - The siting and design of outbuildings in the Residential zone shall be in accordance with the Residential Design Codes or any local planning policy adopted by the local government. Comment – Refer to the R-Codes and LPP23 assessment below.
- 4.22.3 – Notwithstanding any other provisions contained in the Scheme, the local government may refuse to grant development approval for the development or use of any outbuilding on any Residential zoned lot which does not contain a dwelling. Comment – Outbuildings are ancillary development to a dwelling in the context of residential zoned land. The Applicant proposes to construct a dwelling in the future, however has not submitted a Building Permit application.

Clause 4.6 enables the local government to approve an application despite the non-compliance or non-compliances unconditionally or subject to conditions as it may see fit. The power conferred in this clause may only be exercised if the local government is satisfied that the proposed development would be appropriate having regard to clause 67 of the Regulations and the non-compliance will not have an adverse effect upon occupiers or users of the development, the inhabitants of the locality or the future development of the locality.

Planning and Development (Local Planning Schemes) Regulations 2015

Clause 67 of the Regulations sets out the matters for consideration for local government when determining an application for development approval.

Sub-clauses (a), (c), (g), (m), (n) and (s) are applicable to the proposal and have been considered in the assessment of this application. The development is consistent with the aims of LPS6; relevant policies have been considered; and any impacts on the locality have been considered.

State Planning Policy 3.1 – Residential Design Codes (R-Codes)

Clause 5.4.3 of the R-Codes applies to outbuildings and the deemed-to-comply provisions have been assessed as follows:

- Are not habitable. Comment – it is a concern that if an outbuilding is constructed without a dwelling that it could be used for habitation. It is recommended a condition be imposed should the development be approved.
- Do not exceed 60m² or 10% of the aggregate of the site area, whichever is the lesser. Comment – the proposed outbuilding is 83.54m² in area. Does not comply.
- Do not exceed 2.4m in wall height. Comment – the proposed wall height is 2.5m. Does not comply.
- Do not exceed ridge height of 4.2m. Comment – the proposed ridge height is 2.6m. Complies.
- Are not within the primary or secondary street setback area. Comment – outbuilding is proposed in rear yard. Complies.
- Do not reduce the amount of open space. Comment – 60% open space required. 20.7% site coverage proposed with future dwelling. Does not comply (minimal variation if dwelling is constructed as per submitted sit plan.)
- Are setback in accordance with Table 2a. Comment – required setback to side 1m and 1.5m to rear. Complies.

Local Planning Policy No. 23 – Outbuildings in Residential and Mixed Use Zones

The applicable clauses of LPP23 have been assessed as follows:

- Cl. 6.3 permits outbuildings of up to 90m² on site with an area greater than 1,000m² and less than 2,000m². Comment – the proposed outbuilding will have an area of 83.54m². Complies.

- Cl. 6.4 permits a wall height of up to 3.5m when located greater than 1.0m from the boundary. Comment – wall height is 2.5m. Complies.
- Cl. 6.5 permits a ridge height of 4.5m when located greater than 1.0m from the boundary. Comment – ridge height is 2.6m. Complies.
- Cl. 6.9 requires walls and roofing material to be non-reflective. Comment – walls to be clad in Colourbond Surfsmist. Complies.
- Cl. 6.10 requires new materials to be used. Comment – new eco-cladding/panelling to be used. Complies.
- Cl. 6.11 requires the outbuilding to be located on a property where a house is existing, or where a house is approved concurrently. Comment – the property is vacant. The Applicant has advised that he intends to construct a dwelling in the future and has indicated the footprint on the site plan, however has not provided any indicative timing and has not, to date, applied for a Building Permit.

Policy Implications

The development application proposes to construct an outbuilding before the construction of a dwelling on a lot zoned Residential. Outbuildings are ancillary development to a dwelling on residential land and approval of this application is varying clause 4.22.3 of LPS6 and clause 6.11 of LPP23.

Any time a scheme or policy provision is varied there are implications. Policies should be applied consistently to ensure that appropriate weight is given to their provisions in decision making, including during appeals at the State Administrative Tribunal.

Stakeholder Engagement / Consultation

No consultation has been carried out or was deemed necessary to contribute to the assessment of this application.

Risk Implications

Variation of policy carries risk that the policies will be given less weight in an appeal situation.

OFFICER'S COMMENT

There are three (3) options available to Council to determine this application in accordance with the Regulations:

1. Approve the application;
2. Approve the application with conditions; or
3. Refuse the application.

There is an option for Council to approve the application, subject to the lodgement of a bond that would cover the costs of demolition should the dwelling not be constructed within a specified period, for example two (2)

years. Other conditions, such as preventing habitation of the dwelling and management of stormwater should also be included.

Should Council be of a mind to refuse the application, the reasons of refusal should include inconsistency with clause 4.22.3 of LPS6 and clause 6.11 of LPP23.

Taking into consideration the Applicant's submission and his genuine intent to construct a dwelling in the near future, it is recommended that the application be approved subject to conditions, including payment of a bond.

RECOMMENDATION

That Council approve the development application in accordance with the provisions of Northam Local Planning Scheme No. 6 for the construction of an outbuilding on Lot 123 (64) Wilson Street, Grass Valley, subject to the following conditions:

General conditions

1. The development hereby permitted must substantially commence within two (2) years from the date of this determination notice.
2. The development hereby permitted taking place in accordance with the stamped approved plans.
3. Earthworks shall not exceed 500mm cut or fill without prior approval from the Shire of Northam.

Conditions to be met prior to the commencement of any works

4. A bond of \$2,000 shall be paid to the Shire of Northam, which will be refunded upon substantial commencement of the construction of a dwelling on the subject lot within two (2) years from the date of this determination. Should the construction of a dwelling not commence within two (2) years, the Shire of Northam will require demolition of the outbuilding or demolish the outbuilding using the bond funds.

Conditions to be met prior to occupation of the development

5. A crossover shall be constructed to the satisfaction and specifications of the Shire of Northam.

Conditions requiring ongoing compliance

6. The outbuilding shall not be used for habitable, commercial, or industrial purposes.
7. Stormwater shall be managed on site to the satisfaction of the Shire of Northam.

Attachment 1



The Shire of Northam does not warrant the accuracy of information in this publication and any person using or relying upon such information does so on the basis that The Shire of Northam shall bear no responsibility or liability whatsoever for any errors, faults, defects or omissions in the information.

64 Wilson St Grass Valley

11/10/2017

1:2000



Attachment 2

**PROPOSED SHED
FOR MR S. MURRAY
LOT 125 – 64 WILSON STREET
GRASS VALLEY**

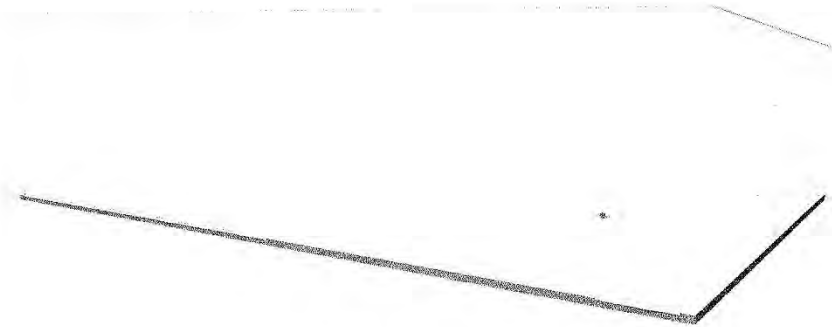

AVON VALLEY DESIGN & DRAFTING SERVICE ©

56 WOODLEY FARM DRIVE

NORTHAM W.A. 6401

Phone / Fax (08) 9622 2816 Mobile 0419 909 485

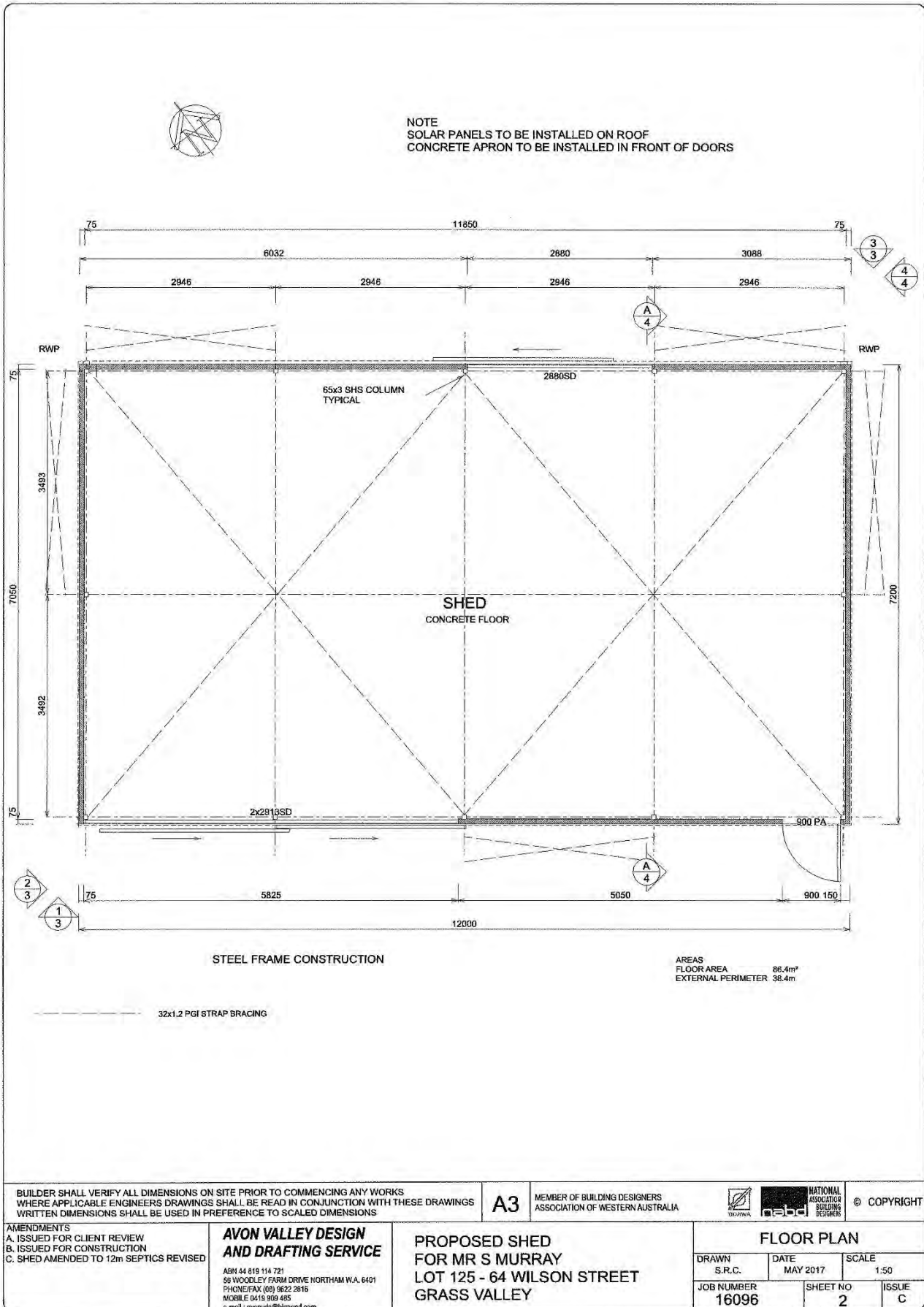

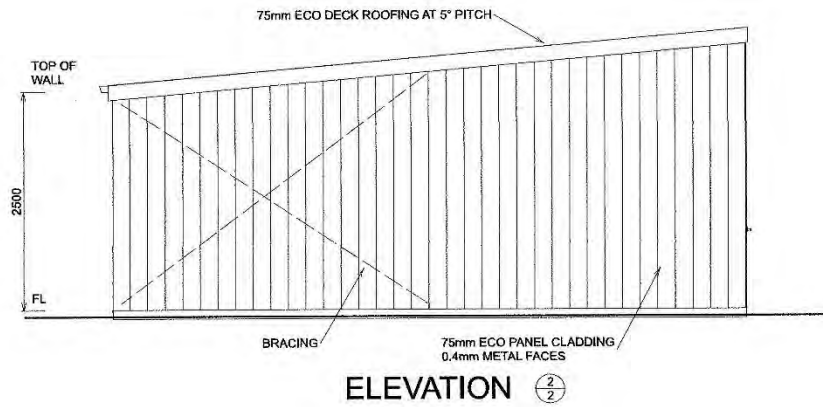
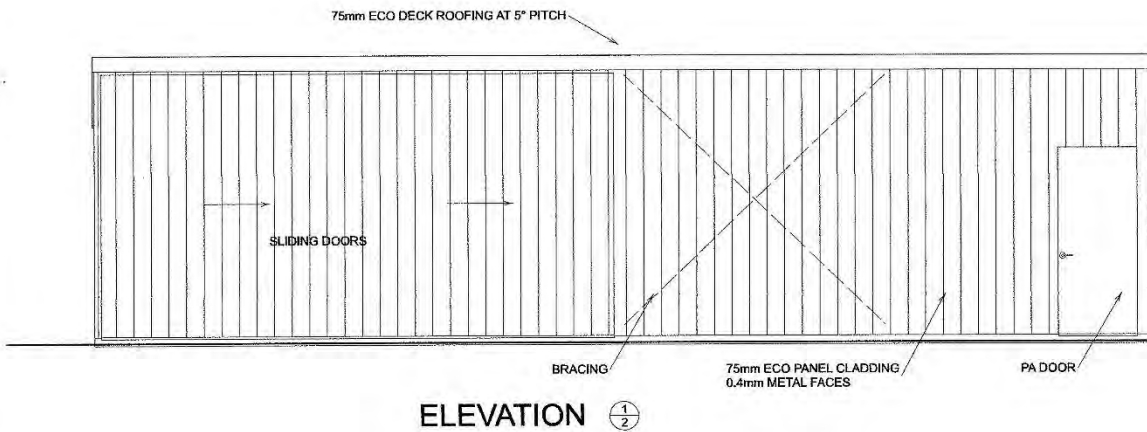

NOTE
WALL CLADDING TO BE COLORBOND SURFMIST

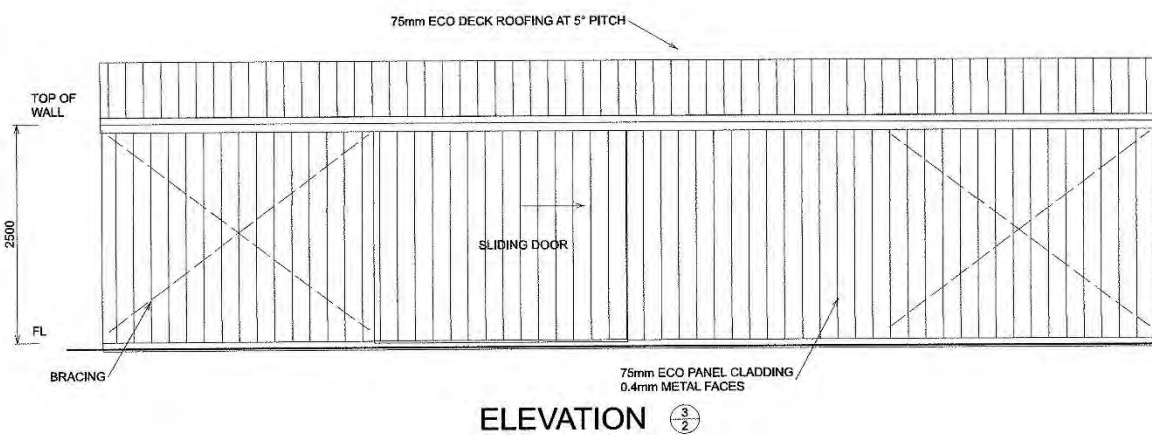

BUILDER SHALL VERIFY ALL DIMENSIONS ON SITE PRIOR TO COMMENCING ANY WORKS
WHERE APPLICABLE ENGINEERS DRAWINGS SHALL BE READ IN CONJUNCTION WITH THESE DRAWINGS
WRITTEN DIMENSIONS SHALL BE USED IN PREFERENCE TO SCALED DIMENSIONS

A3

MEMBER OF BUILDING DESIGNERS
ASSOCIATION OF WESTERN AUSTRALIA



NATIONAL
ASSOCIATION
OF BUILDING
DESIGNERS

© COPYRIGHT

AMENDMENTS
A. ISSUED FOR CLIENT REVIEW
B. ISSUED FOR CONSTRUCTION
C. SHED AMENDED TO 12m SEPTICS REVISED

**AVON VALLEY DESIGN
AND DRAFTING SERVICE**

ABN 44 819 114 721
56 WOODLEY FARM DRIVE NORTHAM W.A. 6401
PHONE/FAX (08) 9822 2816
MOBILE 0419 909 485
e-mail : avonvds@bigpond.com

PROPOSED SHED
FOR MR S MURRAY
LOT 125 - 64 WILSON STREET
GRASS VALLEY

ELEVATIONS

DRAWN S.R.C.	DATE MAY 2017	SCALE 1:50
JOB NUMBER 16096	SHEET NO 3	ISSUE C

PRINTED 3:28:35 PM 4/09/2017 VERSION X9

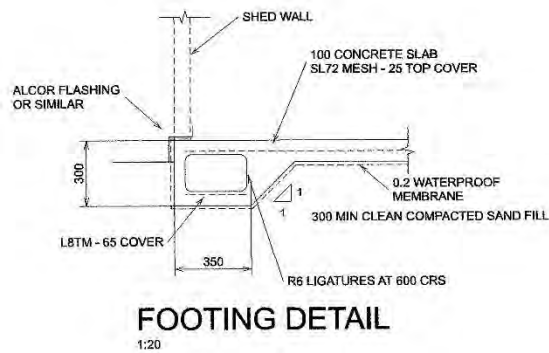
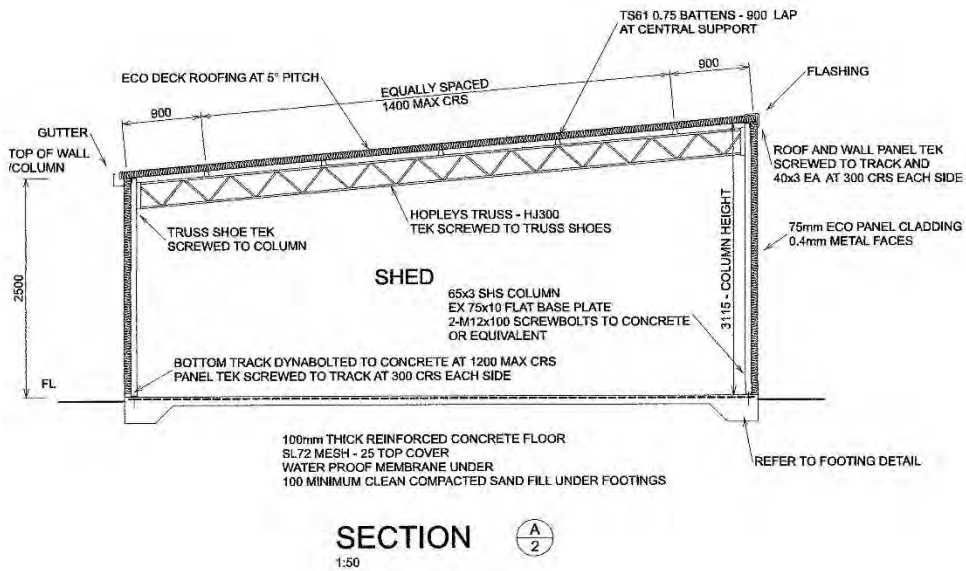
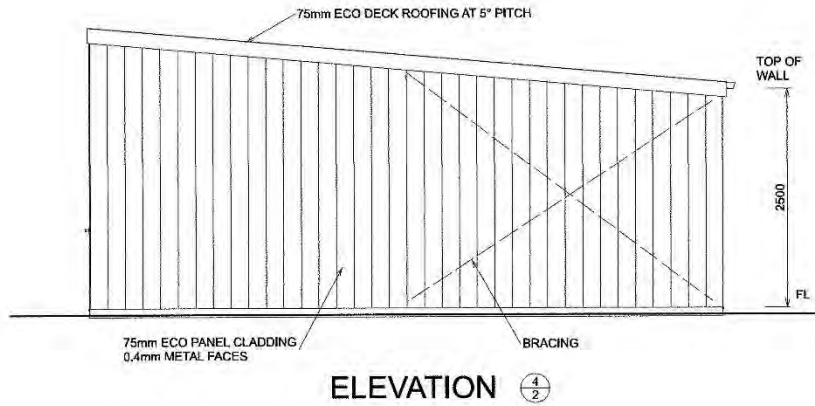

BUILDER SHALL VERIFY ALL DIMENSIONS ON SITE PRIOR TO COMMENCING ANY WORKS WHERE APPLICABLE ENGINEERS DRAWINGS SHALL BE READ IN CONJUNCTION WITH THESE DRAWINGS WRITTEN DIMENSIONS SHALL BE USED IN PREFERENCE TO SCALED DIMENSIONS		A3 MEMBER OF BUILDING DESIGNERS ASSOCIATION OF WESTERN AUSTRALIA	 © COPYRIGHT						
AMENDMENTS A. ISSUED FOR CLIENT REVIEW B. ISSUED FOR CONSTRUCTION C. SHED AMENDED TO 12m SEPTICS REVISED	AVON VALLEY DESIGN AND DRAFTING SERVICE ABN 44 819 114 721 58 WOODLEY FARM DRIVE NORTHAM W.A. 6401 PHONE/FAX (08) 9622 2816 MOBILE 0419 938 485 e-mail: avonvds@bigpond.com	PROPOSED SHED FOR MR S MURRAY LOT 125 - 64 WILSON STREET GRASS VALLEY	ELEVATIONS/SECTIONS & DETAILS <table border="1"> <tr> <td>DRAWN S.R.C.</td> <td>DATE MAY 2017</td> <td>SCALE 1:50</td> </tr> <tr> <td>JOB NUMBER 16096</td> <td>SHEET NO 4</td> <td>ISSUE C</td> </tr> </table>	DRAWN S.R.C.	DATE MAY 2017	SCALE 1:50	JOB NUMBER 16096	SHEET NO 4	ISSUE C
DRAWN S.R.C.	DATE MAY 2017	SCALE 1:50							
JOB NUMBER 16096	SHEET NO 4	ISSUE C							

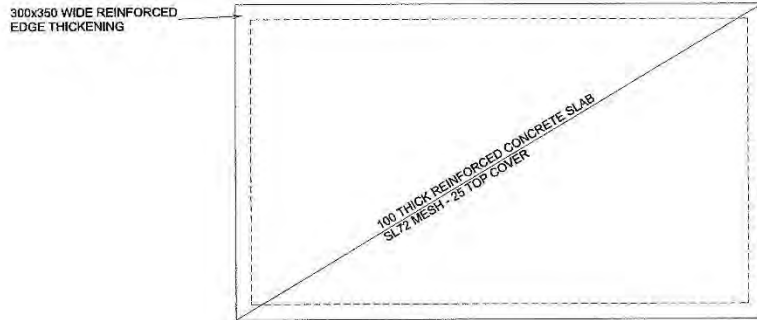

SLAB & FOOTINGS

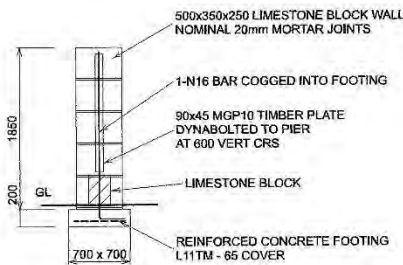

SECTION B-B

1:50

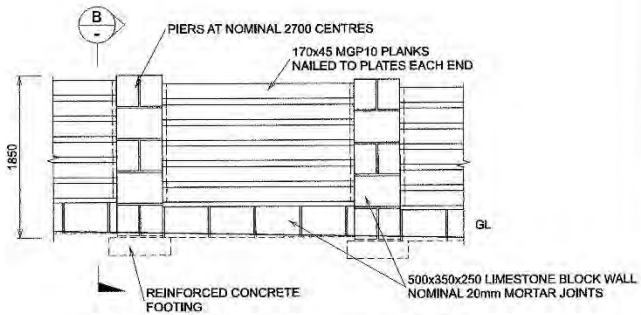

TYPICAL WALL ELEVATION

1:50

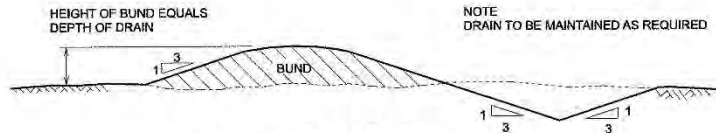

CUTOFF DRAIN

N.T.S.

DESIGN DATA

1. ROOF LIVE LOAD IS 0.25 kPa TO AS/NZS 1170.1
2. WIND LOADS ARE TO AS/NZS 1170.2 FOR THE WIND REGION A1 AND TERRAIN CATEGORY 2
3. EARTHQUAKE LOADS ARE TO AS 1170.4 HAZARD FACTOR 'Z' = 0.14
4. IMPORTANCE LEVEL = 2
5. FOOTINGS ARE DESIGNED TO FOUND ON TYPE S SOIL AS DEFINED IN AS2670

EARTHWORK NOTES

1. TOPSOIL TO BE REMOVED
2. GRUB OUT ANY ROOTS AND REMOVE ANY DELETERIOUS MATERIAL
3. CLEAN SAND FILL TO BE IMPORTED AND COMPACTED IN 300 MAX LAYERS
4. ALL SOIL UNDER FOOTINGS AND SLABS SHALL BE WELL COMPACTED
5. SOIL SHALL BE COMPACTED TO ACHIEVE 95% OF THE MODIFIED MAXIMUM SOIL DRY DENSITY
6. PERTH PENETROMETER READINGS TAKEN IN COMPACTED SAND SHALL BE 7 BLOWS PER 300 OR BETTER
7. WHERE APPLICABLE EMBANKMENT SLOPE TO BE AT ANGLE OF REPOSE OF SOIL TYPE - REFER TO BCA VOL 2 TABLE 3.1.1.1
8. ALL WATER TO BE DIVERTED AWAY FROM HOUSE AND SEPTIC SYSTEM FROM COMMENCEMENT OF CONSTRUCTION

CONCRETE NOTES

- 1 ALL CONCRETE WORK SHALL BE TO AS 3600
- 2 CONCRETE SHALL BE GRADE N20-20-80
- 3 ALL WELDED WIRE MESH SHALL BE GRADE 500L TO AS/NZS 4671
- 4 ALL REINFORCING BAR SHALL BE GRADE 500N TO AS/NZS 4671
- 5 ALL CONCRETE SHALL BE CURED BY KEEPING THE EXPOSED CONCRETE SURFACES CONTINUOUSLY WET FOR A PERIOD OF 7 DAYS MINIMUM AFTER POURING
- 6 ALL FERROUS ITEMS EXCEPT REINFORCING EMBEDDED IN CONCRETE SHALL BE HOT DIP GALVANISED AND PAINTED WITH BITUMINOUS PAINT TO MANUFACTURERS SPECIFICATIONS.

STEELWORK NOTES

1. ALL STEELWORK SHALL BE TO AS4100
2. ALL SHS & RHS MEMBERS SHALL BE GRADE 450 TO AS/NZS 1163
3. ALL ROLLED SECTIONS SHALL BE GRADE 300 TO AS/NZS 3679.1
4. ALL WELDING SHALL BE TO AS/NZS 1554.1
5. ALL WELDS SHALL BE 6mm CONTINUOUS FILLET WELDS UNLESS NOTED OTHERWISE
6. ALL STEELWORK AND BOLTS SHALL BE CORROSION TREATED AS PER SPECIFICATION

BUILDER SHALL VERIFY ALL DIMENSIONS ON SITE PRIOR TO COMMENCING ANY WORKS WHERE APPLICABLE ENGINEERS DRAWINGS SHALL BE READ IN CONJUNCTION WITH THESE DRAWINGS WRITTEN DIMENSIONS SHALL BE USED IN PREFERENCE TO SCALED DIMENSIONS

A3

MEMBER OF BUILDING DESIGNERS ASSOCIATION OF WESTERN AUSTRALIA



© COPYRIGHT

AMENDMENTS
A. ISSUED FOR CLIENT REVIEW
B. ISSUED FOR CONSTRUCTION
C. SHED AMENDED TO 12m SEPTICS REVISED

AVON VALLEY DESIGN AND DRAFTING SERVICE

ABN 44 819 114 721
56 WOODLEY FARM DRIVE NORTHAM W.A. 6401
PHONE/FAX (08) 9622 2818
MOBILE 0419 959 485
e-mail: avonwvds@optusnet.com.au

PROPOSED SHED
FOR MR S MURRAY
LOT 125 - 64 WILSON STREET
GRASS VALLEY

SECTIONS & DETAILS

DRAWN S.R.C.	DATE MAY 2017	SCALE 1:20 1:50
JOB NUMBER 16096	SHEET NO 5	ISSUE C

PRINTED 3:26:35 PM 4/09/2017 VERSION X8

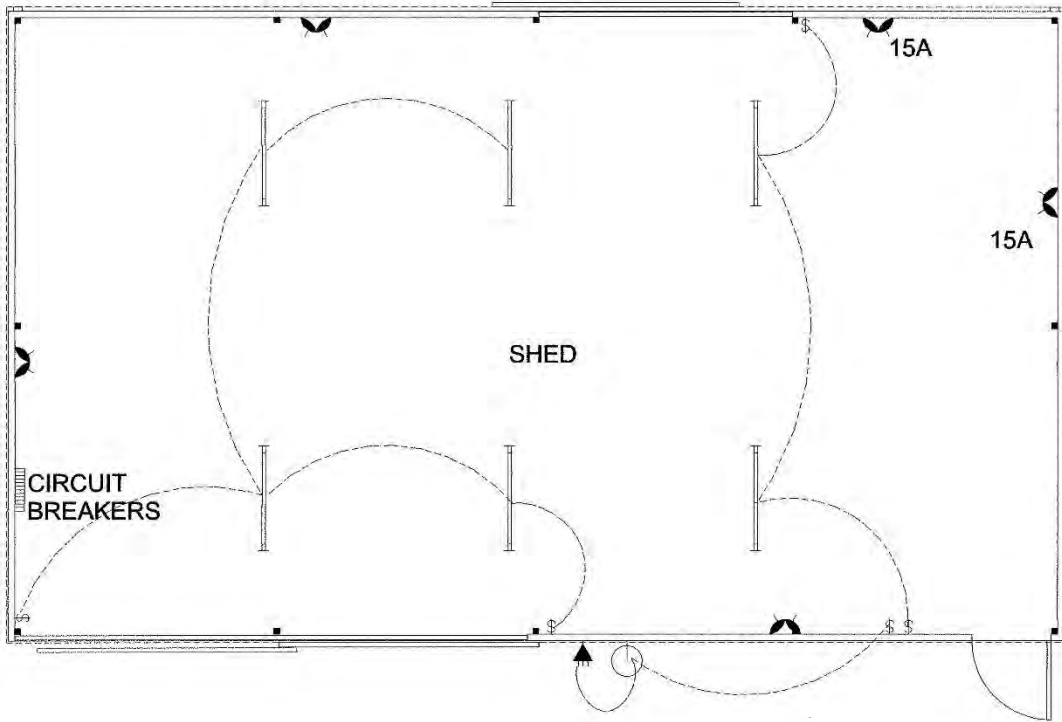

METER BOX LOCATED ON HOUSE

Electrical Legend

○	ROUND FLUORO	☎	PHONE PT
○	CEILING LIGHT	⊗	CEILING FAN
○	WALL LIGHT	⊗	CEILING FAN LIGHT
⊕	DOWN LIGHT	☹	SMOKE DETECTOR
⊕	OYSTER LIGHT	⊗	TIMERBOOSTER SWITCH FOR HWS
—	FLUORO LIGHT	⊗	ELEC METER BOX
⊗	4 LAMP COMB EX FAN	⊗	DOUBLE GPO @ 300 AFL
⊗	2 LAMP COMB EX FAN	⊗	DOUBLE GPO @ 1100 AFL
⊕	SENSOR	⊗	QUAD GPO @ 1100 AFL
⊕	EXHAUST FAN UNFLUMED	⊗	DOUBLE GPO @ 1550 AFL
⊕	EXHAUST FAN FLUMED	⊗	WPROOF DOUBLE GPO
⊕	GAS POINT	⊗	CEILING MOUNTED GPO
⊕	TV POINT		

BUILDER SHALL VERIFY ALL DIMENSIONS ON SITE PRIOR TO COMMENCING ANY WORKS
WHERE APPLICABLE ENGINEERS DRAWINGS SHALL BE READ IN CONJUNCTION WITH THESE DRAWINGS
WRITTEN DIMENSIONS SHALL BE USED IN PREFERENCE TO SCALED DIMENSIONS

A3

MEMBER OF BUILDING DESIGNERS
ASSOCIATION OF WESTERN AUSTRALIA



© COPYRIGHT

AMENDMENTS
A. ISSUED FOR CLIENT REVIEW
B. ISSUED FOR CONSTRUCTION
C. SHED AMENDED TO 12m SEPTICS REVISED

**AVON VALLEY DESIGN
AND DRAFTING SERVICE**

ABN 44 819 114 721
56 WOODLEY FARM DRIVE NORTHAM W.A. 6401
PHONE/FAX (08) 9822 2816
MOBILE 0419 9106 485
e-mail - avonvalley@avonvalley.com

PROPOSED SHED
FOR MR S MURRAY
LOT 125 - 64 WILSON STREET
GRASS VALLEY

ELECTRICAL PLAN

DRAWN S.R.C.	DATE MAY 2017	SCALE 1:50
JOB NUMBER 16096	SHEET NO 6	ISSUE C

PRINTED 3:26:35 PM 4/08/2017 VERSION X9

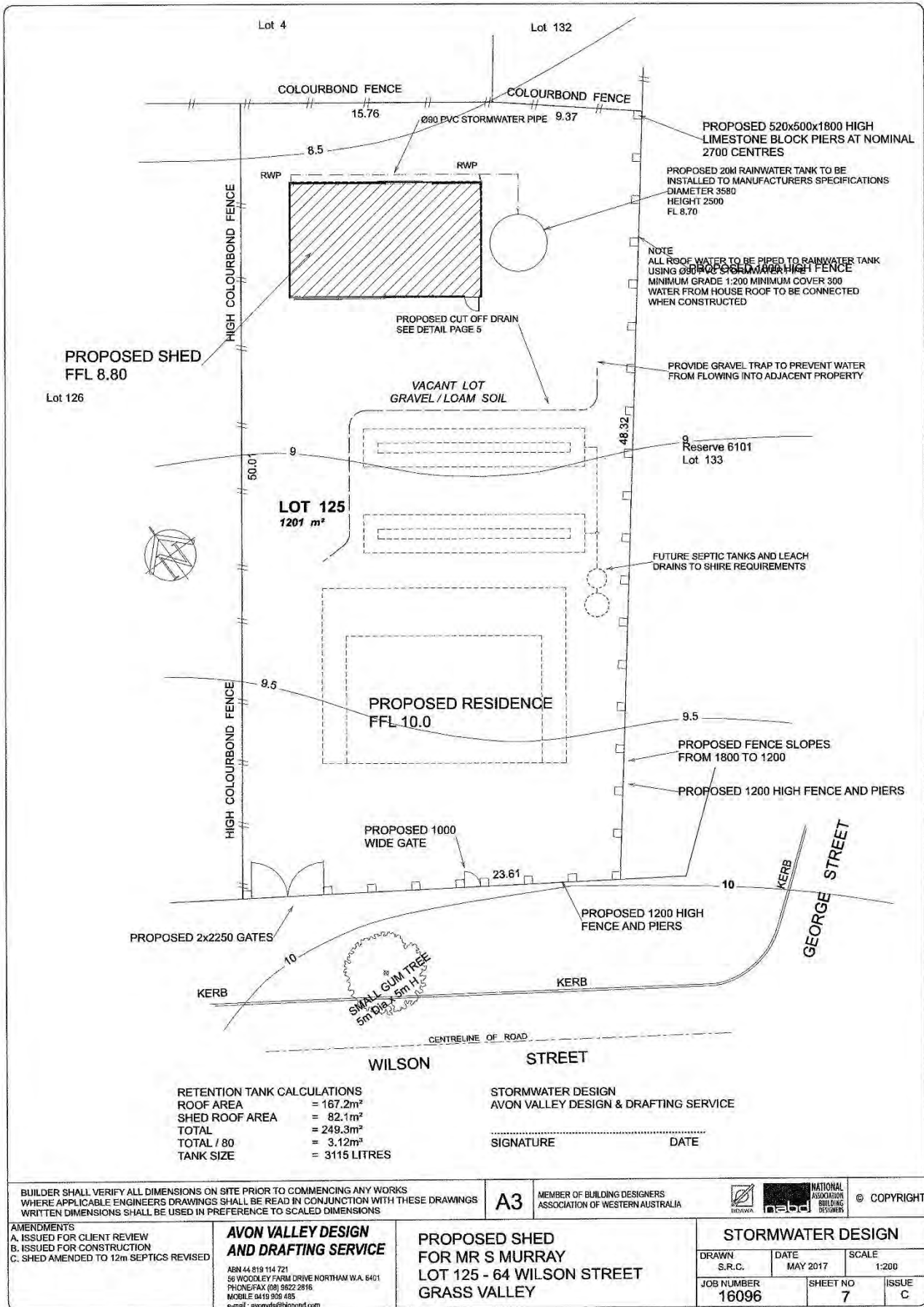

12.3.4 Pedestrian Access Way – Adjacent to 16 Brown Road and 51 Olive Road, Wundowie

Address:	Brown Road, Wundowie
Applicant:	N/A
Owner:	Crown
File Reference:	A1054/A1765
Reporting Officer:	Chadd Hunt Executive Manager Development Services
Responsible Officer:	Chadd Hunt Executive Manager Development Services
Voting Requirement	Simple Majority

BRIEF

Council has been approached from several different parties regarding the current and future status of a Pedestrian Access way (PAW) located at the end of the Brown Road cul-de-sac in Wundowie.

The purpose of this report is for Council to determine the future development, closure or amendment of the land parcel.

ATTACHMENTS

- Attachment 1: Location Plans.
- Attachment 2: Certificate of Title.
- Attachment 3: Diagram of Survey.

BACKGROUND / DETAILS

The PAW is approximately 10 metres wide and 240 metres long and connects the end of Brown Road to Olive Road. It appears that the PAW was created as a component of the subdivision of the surrounding area in 1981 however there is no Council records that indicates what the purpose of the PAW was for at the time of subdivision. Staff have made inquiries with both the Department of Planning Lands and Heritage regarding the original intent of the PAW being created however they have advised that there is little historical information on it origins. The Department however also indicated that it is likely that the PAW was created to provide emergency access.

It is understood that in a number of subdivisions within semi-rural areas a PAW was provided as a means for emergency access/strategic firebreaks however

as stated above there are no Council records that indicate what the initial purpose for the PAW was.

A search of Council records indicate that in around 2010 an issue with antisocial behaviour both on and through the PAW was raised by an adjoining landowner and attempts to block access for both vehicles and pedestrians have been ongoing since that time. It appears that the initial placement of the rock barriers was to prevent vehicular access along the PAW and more recently rocks have been placed to restrict all access to the PAW.

More recently other landowners within the vicinity have raised the issue of safety associated with the cul-de-sac and if the PAW is required for emergency access.

In staff's opinion there are several options that Council has with respect to the current and future status of the PAW.

Option 1 – Determine that the PAW is no longer required and permanently close and amalgamate the land with the adjoining properties. If option is resolved there is a complete process that needs to be followed that has been developed by the (then) Department of Planning and Department of Lands. This process includes consultation, justification for the closure including anti-social behaviour and alternate cycle and pedestrian paths. These guidelines have been developed more on an urban setting where the use of the PAW is for pedestrian and cycle movements.

Option 2 – Reinstate the PAW as an emergency access. This would necessitate the improvement of the surface to allow access by a two wheel drive standard. In a number of similar situations a gate (unlocked) is placed partially across the PAW to deter access by unauthorised vehicles whilst still allowing bicycles and pedestrians to access the laneway.

Option 3 – The PAW is retained and the restriction put in place to prevent vehicle and pedestrian access on a permanent basis. This option would involve putting permanent barriers on either end of the PAW and restricting access to it. This option effectively closes the PAW whilst not going through the formal closure and disposal process.

It is staff's recommendation that Option 2 is adopted.

CONSIDERATIONS

Strategic Community / Corporate Business Plan

Theme Area 5: Infrastructure & Service Delivery

Outcome 5.2: Environmental risks are proactively managed to minimise impact on residents. Continued bushfire management planning and mitigation works.

Financial / Resource Implications

There is potential costs to Council depending on the option that it wishes to pursue. The physical closure of the PAW will have limited financial impact whilst if the PAW is to be opened as an emergency access there will be financial resource required to bot upgrade it to a trafficable standard and potentially the erection of gates to prevent unauthorised access.

There is funds available in GL 05062052 Grade Fire Breaks that could be utilised to offset these costs.

Legislative Compliance

The Brown Road area is currently located within a Bush Fire Prone area as defined by the Department of Fire And Emergency Services. The current Guidelines for Planning in Bushfire Prone Areas would indicate that if the subdivision is proposed in a bush fire prone area it should have at least two safe access routes. Obviously as this is an existing subdivision officers comments are based on the assumption that if subdivision was to occur today that the PAW should be developed as an emergency exit route.

The PAW is technically defined as a thoroughfare under the provisions of the Local Government Act 2005, Schedule 9.1 of the Act states:

5. Gates across public thoroughfares
 - (1) *Regulations may be made under which a local government may authorise a person to have across a public thoroughfare that is under its control or management a gate or other device that enables motor traffic to pass and prevents the straying of livestock.*
 - (2) *Regulations may include provisions for ensuring that a gate that has been placed across a public thoroughfare with the authority of a local government is not left open.*

Clause 9 of the Local Government (Uniform Local Provisions) Regulations 1996 gives Council the power to approve the erection of the gate.

Policy Implications

N/A.

Stakeholder Engagement / Consultation

There has been no formal consultation undertaken at this stage however several landowners in the vicinity have previously raised in writing the issue of the emergency access and antisocial behaviour related to the PAW.

Staff have contacted 4 of the 5 landowners in the immediate vicinity of the PAW and 3 have indicated desire to have it remain open for emergency vehicle access.

Consultation was also undertaken with Department of Planning, Lands and Heritage and internal staff.

Risk Implications

There is a risk to Council is in taking no action with respect to the PAW. Given that staff have indicated that it should be retained and upgraded for emergency access there is a risk that should the PAW not be upgraded or available for access and an incident occurs then Council could be held liable.

OFFICER'S COMMENT

Staff have assessed the fire risk in the area and from that perspective would recommend that the PAW be retained for emergency access in case of an incident. This assessment is based on the current planning and bushfire guidelines if the subdivision was to be created in the current day. As an emergency access point there are mechanisms that can be put in place such as gates and other obstructions (such as bollards etc.) that can assist with the prevention of unauthorised access however there is a risk that the perceived antisocial behaviour will continue.

On this basis it is recommended that Council resolve to implement Option 2 above and allocate resources to undertake the track improvement and the installation of suitable barriers

RECOMMENDATION

That Council:

1. Resolves to retain the PAW located between Brown Road and Olive Road as an emergency access way only;
2. Upgrade the PAW to ensure that the access way is trafficable by a 2 wheel drive vehicle for emergency situations; and
3. Install an unlocked gate at either end of the PAW to deter unwanted vehicles utilising the access way.

Attachment 1
Location Plan - Brown Road Laneway



Attachment 2

REGISTER NUMBER 55/P12671	
DUPLICATE EDITION N/A	DATE DUPLICATE ISSUED N/A

WESTERN AUSTRALIA



RECORD OF CERTIFICATE OF TITLE
UNDER THE TRANSFER OF LAND ACT 1893

THE PERSON DESCRIBED IN THE FIRST SCHEDULE IS THE REGISTERED PROPRIETOR OF AN ESTATE IN FEE SIMPLE IN THE LAND DESCRIBED BELOW SUBJECT TO THE RESERVATIONS, CONDITIONS AND DEPTH LIMIT CONTAINED IN THE ORIGINAL GRANT (IF A GRANT (ISSUED) AND TO THE LIMITATIONS, INTERESTS, ENCUMBRANCES AND NOTIFICATIONS SHOWN IN THE SECOND SCHEDULE.

REGISTRAR OF TITLES



LAND DESCRIPTION:
LOT 55 ON PLAN 12671

REGISTERED PROPRIETOR:
(FIRST SCHEDULE)
STATE OF WESTERN AUSTRALIA
(A C143612) REGISTERED 22/5/1981

LIMITATIONS, INTERESTS, ENCUMBRANCES AND NOTIFICATIONS:
(SECOND SCHEDULE)
1. VESTED BY THE REGISTRAR UNDER SECTION 20A OF THE TOWN PLANNING AND DEVELOPMENT ACT 1928 FOR THE PURPOSE OF PEDESTRIAN ACCESSWAY

Warning: A current search (if the sketch of the land should be obtained where detail of position, dimensions or area of the lot is required.
* Any entries preceded by an asterisk may not appear on the current edition of the duplicate certificate of title.
Lot as described in the land description may be a lot of location.

-----END OF CERTIFICATE OF TITLE-----

STATEMENTS:
The statements set out below are not intended to be nor should they be relied on as substitutes for inspection of the land and the relevant documents or for local government, legal, surveying or other professional advice.

SKETCH OF LAND:	P12671
PREVIOUS TITLE:	1279-141
PROPERTY STREET ADDRESS:	NO STREET ADDRESS INFORMATION AVAILABLE.
LOCAL GOVERNMENT AUTHORITY:	SHIRE OF NORTHAM
RESPONSIBLE AGENCY:	DEPARTMENT OF LANDS (SPAW)

NOTE 1: L659382 NO DUPLICATE ISSUED

Attachment 3

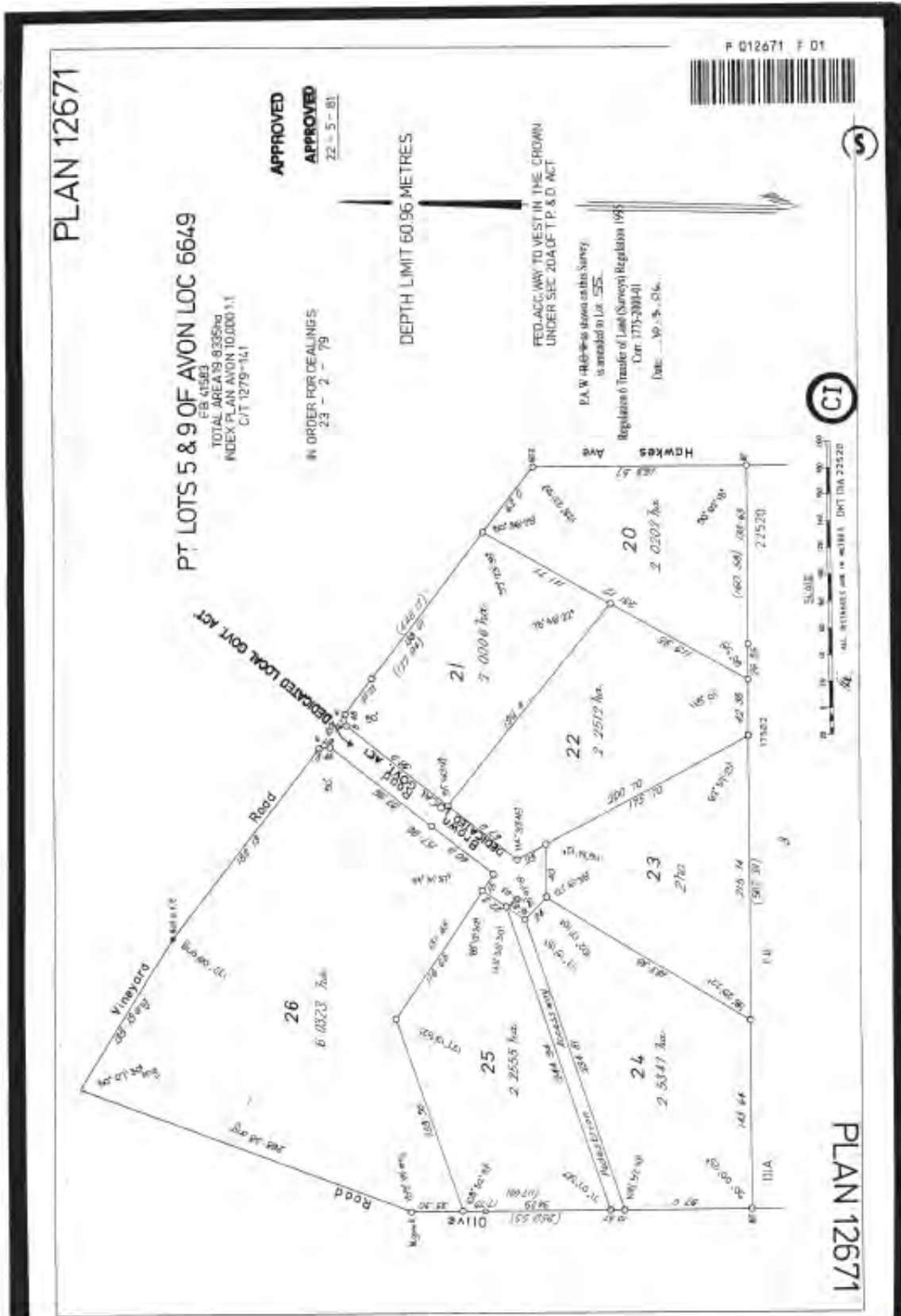

LANDGATE COPY OF ORIGINAL NOT TO SCALE Thu Sep 14 09:05:38 2017 JOB 54884866

Landgate
www.landgate.wa.gov.au

12.3.5 Application for Development Approval - Proposed Rural Pursuit
(Growing Advanced Trees) at 19 Brown Road, Wundowie

Address:	Lot 23 (19) Brown Road, Wundowie
Owner:	C & D Davidson
File Reference:	A1386 / P17094
Reporting Officer:	Jacky Jurmann Planning Consultant
Responsible Officer:	Chadd Hunt Executive Manager Development Services
Voting Requirement	Simple Majority

BRIEF

A development application has been submitted to obtain consent to use Lot 23 (19) Brown Road, Wundowie for the purposes of growing advanced trees in conjunction with the Applicant's main nursery, Misty Ridge Plant Farm, located at 16 Brown Road, Wundowie.

In response to consultation conducted during the assessment of the application, two (2) submissions were received raising concerns regarding the proposal.

The issues raised can be addressed by conditions and therefore, the application is being recommended for conditional approval.

ATTACHMENTS

Attachment 1: Location Plan.

Attachment 2: Site Plan.

BACKGROUND / DETAILS

Lot 23 (19) Brown Road, Wundowie has an area of 2 hectares and is currently vacant (refer to Attachment 1).

The application proposes to use the land for the purposes of growing advanced trees in conjunction with the Applicant's main nursery, Misty Ridge Plant Farm, located at 16 Brown Road, Wundowie.

In support of the application, the Applicant has advised that:

- "1. Plants will be grown in planter bags holding a minimum of 15 litres under trickle irrigation.*

2. *Slow release fertiliser will be used in accordance with Department of Primary Industries and Regional Development Regulations for nursery stock and manufacturers guidelines. No animal manures will be used on any container stock.*
3. *No plants will be sold from the property.*
4. *Any herbicides or pesticides will be used in accordance with Department of Primary and Regional Development Regulations and manufacturer's guidelines."*

CONSIDERATIONS

Strategic Community / Corporate Business Plan

Theme Area 1: Economic Growth.

Outcome 1.1: The Shire of Northam is an attractive investment destination for a variety of economic sectors.

- Ensure the Shire of Northam is a welcoming and easy place for quality investment to occur.

Financial / Resource Implications

There are no direct financial / budgetary implications for the Shire of the recommendations of this report provided appropriate conditions are attached to any approval that is granted to establish and manage the use.

Legislative Compliance

Shire of Northam Local Planning Scheme No. 6 (LPS6)

Under the provisions of LPS6, the proposal is best defined as a 'Rural Pursuit' and is a 'D' discretionary use, which requires development consent from the local government.

The property is located within the Rural Residential No. 5 area and is therefore subject to the provisions of Schedule 7 of LPS6, which requires areas shown in the Revegetation Management Area to be revegetated.

Relevant clauses of LPS6 have been considered as follows:

Clause	Criteria	LPP / Scheme Provision	Proposed by Development	Criteria Met / Condition Required
LPS6, 3.2.9	Zone Objectives	Preserve amenity, ensure landscape protection and conservation, control land use impacts.	Growing of advance trees only. No retailing of plants.	Yes. Condition recommended to reinforce no retailing.
LPS6, 4.5	Site Development & Standards	Setbacks: 15m front; 10m side & rear boundaries.	Not defined.	Condition recommended.

Clause	Criteria	LPP / Scheme Provision	Proposed by Development	Criteria Met / Condition Required
LPS6, 4.13	Car Parking	Not specified in Table 3.	No details provided.	Yes. No retailing, therefore not required.
LPS6, 4.16	Access for Loading & Unloading Vehicles	Provision to be made and vehicles to enter and exit in forward direction.	No details provided.	Condition recommended.
LPS6, 4.20	Parking Commercial Vehicles in RR zone	Vehicle in excess of 4.5 tonne not permitted without approval.	No details provided.	Condition recommended, including hours.
LPS6, 4.24	Advertisements	Not without approval unless exempt.	No details provided.	Condition recommended.
LPS6, 4.30.1	Development in RR zone	In accordance with Schedule 7.	Revegetation required in Revegetation Management Area.	Condition recommended.
LPS6, 4.30.3	Development in accordance with Zoning Table	Rural Pursuit 'D' use	DA submitted.	Yes
LPS6, 4.30.5	Sustainable water supply	To be demonstrated.	Approved bore water supply on site.	Yes
LPS6, 4.30.8	Building envelope	Buildings & effluent disposal system within envelope.	No buildings proposed at this stage.	N/a
LPS6, 4.30.11	Removal of trees	No native trees or shrubs to be removed.	Area to be used is within existing cleared area. No further clearing proposed.	Yes. Advice note recommended.
LPS6, 4.30.15	Environmental Management Plan	Areas within EMP to be maintained by owners.	Area to be used defined in existing cleared area.	Condition recommended.
LPS6, Schedule 7, RR5	Condition 1	Areas shown in the Revegetation Management Area to be revegetated.	Area to be used within existing cleared area.	Condition to be imposed.

Planning and Development (Local Planning Schemes) Regulations 2015

Clause	Criteria	LPP / Scheme Provision	Proposed by Development	Criteria Met / Condition Required
LPS Reg. 67(m)	Compatibility of development	Relationship of development	Use low impact. Growing out trees. No retailing.	Condition to be imposed regarding hours of truck movements.
LPS Reg. 67(n)	Amenity of locality	Environmental impacts; character of locality; social impacts.	No impacts identified. No clearing required.	Yes
LPS Reg. 67(o)	Environmental impacts	Effect of development of natural environment and water sources.	Environment Officer advises block is degraded from previous grazing activities. Clearing permit required for further clearing.	Advice note recommended.
LPS Reg. 67(p)	Landscaping	Provision for landscaping made. Whether trees should be preserved.	LPS6, Schedule 7 requires revegetation.	Condition recommended.
LPS Reg. 67(q)	Natural constraints	Suitability of land from flooding, bushfire, etc	No details provided.	Land is bushfire prone. Fire Management Plan required. Condition recommended.
LPS Reg. 67(s)	Adequacy of access & manoeuvring	Provision for access, loading and unloading.	No details provided.	Condition recommended (as per LPS6, 4.16).
LPS Reg. 67(t)	Traffic generation	Capacity of road network and effect.	No retailing proposed. Truck movements associated with plant deliveries.	Condition recommended regarding hours (as per LPS6, 4.20).
LPS Reg. 67(y) & LPP20	Submissions received	Application advertising to adjoining landowners.	Two submissions were received raising concerns about the proposal.	Conditions can be imposed. Refer to Comments section of Report.

Policy Implications

There are no policy implications associated with this proposal. The proposal can be conditioned to meet the provisions of LPS6, the Regulations and to address the issues raised in the submissions.

Stakeholder Engagement / Consultation

Consultation was undertaken with all abutting landowners. Two (2) objections were received regarding the proposal as follows:

No.	Name/Address	Summary of Submission	Officer Comment
1.	Adele Lebechee 59 Olive Road (L19 Brown Road), Wundowie	<ul style="list-style-type: none"> • Herbicide is toxic. • Water runoff will impact vegetation and nature. • No mention of desalination plant and associated environmental issues. 	Applicant has advised that slow release fertiliser will be used. Herbicide and pesticides will be used in accordance with Regulations. Recommend condition.
2.	Andy & Debbie Cairns 51 Olive Road (L24 Brown Road), Wundowie	<ul style="list-style-type: none"> • No mention of desalination plant and emissions that will contribute to climate change. • Property is flood prone. • Brine will erode our property. • Desalinated water is harmful to human health and animals. • Flows from flooding will impact our property, bush, native plants, and wildlife. • Herbicide is toxic and will impact bush. • Pesticides are hazardous. 	<p>The Department of Agriculture have approved the use of bore water. Brine from the desalination process must be disposed at an approved waste facility. Recommend condition.</p> <p>The property is not identified as flood prone on the Department of Water mapping. Recommend condition regarding water runoff.</p>

Risk Implications

There are no risk implications for the Shire of the recommendations of this report provided appropriate conditions are attached to any approval that is granted to establish and manage the use.

OFFICER'S COMMENT

The application has been assessed in accordance with the provisions of the Shire's Local Planning Scheme No. 6. The assessment of the development, including consideration of the issues raised in the submissions, demonstrates that although there are a number of information gaps in the application, the proposal is low impact and can be satisfactorily managed through the imposition of conditions as listed in the Recommendation of this Report.

RECOMMENDATION

That Council grant Development Approval in accordance with the provisions of Shire of Northam Local Planning Scheme No. 6 to the landowners, Chris and Donna Davidson, to use Lot 23 (19) Brown Street, Wundowie for a Rural Pursuit for the purposes of growing advanced trees as outlined in the Application received 6 October 2017 (Application No. P17094), and indicated on the approved plans, subject to the following conditions:

General conditions

1. The development hereby permitted must substantially commence within two years from the date of this determination notice.

2. The development hereby permitted taking place in accordance with the stamped approved plans.
3. No advertisements, other than an exempt business identification sign, shall be displayed without the prior approval of the Shire of Northam.

Conditions to be met prior to commencement of works and/or use

4. An amended site plan shall be submitted for approval:
 - a. Demonstrating compliance with the required boundary setbacks of 15 metres from the front boundary and 10 metres from the side and rear boundaries; and
 - b. identifying all existing trees within the development area intended to be retained and shall be protected prior to occupation, and shall not be removed without the prior approval of the Shire of Northam.
5. An Environmental Management Plan/Revegetation Management Plan shall be submitted for approval to the Shire of Northam prior to the commencement of the use.
6. A Fire Management Plan shall be submitted for approval to the Shire of Northam prior to the commencement of the use.
7. The Applicant shall construct a heavy vehicle crossover to the satisfaction of the Shire of Northam.

Conditions requiring ongoing compliance

8. No retailing of plants is permitted on site.
9. The conditions of the Environmental/Revegetation Management Plan(s) shall be complied with at all times.
10. Truck deliveries are not permitted between the hours of 10.00 pm and 6.00 am.
11. No trucks shall be parked on site without the prior approval of the Shire of Northam.
12. All trucks shall enter and leave the property in a forward direction.
13. Water run-off from the plant growing area shall be managed separately to general stormwater to prevent pollution and runoff into neighbouring properties.
14. Pesticides, fertilisers, manures and soil amendment materials shall be used and stored in accordance with requirements of the Department of Agriculture WA, including storing on impermeable surfaces that are weather-proof and exclude stormwater runoff from other areas.
15. Brine and other waste products from the desalination process shall be disposed of at an approved waste facility.

Attachment 1
LOCATION PLAN – 19 BROWN ROAD, WUNDOWIE



Attachment 2

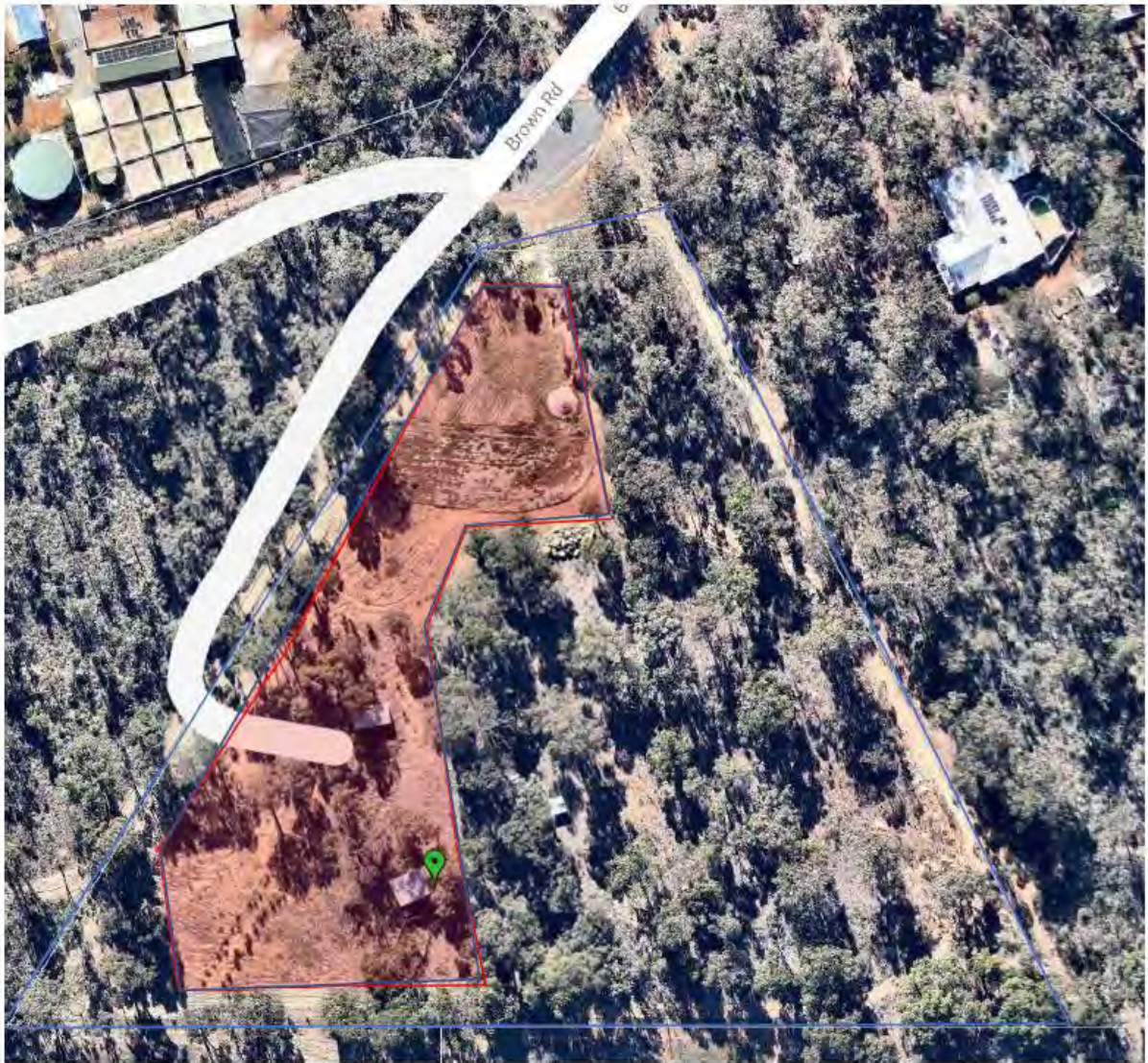

12.3.6 Application for retrospective development approval for earthworks associated with a man-made dam at Lot 237 Brockman Street, Bakers Hill

Address:	Lot 237 Brockman Street, Bakers Hill
Owner:	Teneale Ann Kearney
File Reference:	A15884 / P17100
Reporting Officer:	Kobus Nieuwoudt Manager Planning Services
Responsible Officer:	Chadd Hunt Executive Manager Development Services
Voting Requirement	Simple Majority

BRIEF

Council is asked to consider an application for retrospective development approval for earthworks associated with a man-made dam at Lot 237 Brockman Street, Bakers Hill.

The matter is being referred to Council as, during the neighbour consultation phase, objections to the application have been raised.

ATTACHMENTS

- Attachment 1: Location Plan.
- Attachment 2: Feature Survey of Dam.
- Attachment 3: Schedule of Submissions.

BACKGROUND / DETAILS

Lot 237 Brockman Street is located near the eastern end of Brockman Street in Bakers Hill. The property is landlocked and the owner also owns Lot 238 east of Lot 237. Access to Lot 237 and 238 is facilitated via a right-of-way along the southern boundary of Lot 236 (located east of Lot 237). Refer Attachment 1 – Location Plan.

Lot 237 Brockman Street is 9,308m² in size and zoned Residential R2.5 by Shire of Northam Local Planning Scheme No. 6 (the Scheme).

Key dates and determinations

The following table lists the key dates in regards to this application:

Date	Item
21/08/2013	Council grants retrospective approval for parking of commercial vehicles at Lot 238 Brockman Street.
02/2015	Earthworks undertaken on Lot 237 (dam site).
19/02/2015	Council receives formal complaint regarding 'drainage works' at Lot 237.
23/02/2015	Landowners supply photos and advise that the drainage works were required to construct a sealed driveway in accordance with Condition 18 of their August 2013 retrospective approval.
3/03/2015	Council's Officer's advised the landowners that the Shire didn't require any approvals for the works.
29/03/2016	Shire receives a complaint that the dam wall at Lot 237 had burst over the Easter long weekend.
7/04/2016	Planning Services staff advises the owners in writing to submit an application for development approval to rebuild the dam.
22/04/2016	Planning Services staff contacts the Department of Water as the Shire has received a number of complaints regarding the dam wall that had breached over the Easter long weekend.
28/04/2016	The Department of Water advises that they do not assess, and is precluded by the <i>Rights in Water and Irrigation Regulation 2000</i> from assessing the safety of proposed works (or otherwise), regardless of location – in proclaimed or unproclaimed surface water areas.
26/04/2016	Council's CEO and incumbent EMDS meets with the owners.
10/05/2016	CEO writes to the landowners, advising them that development approval to reconstruct the dam was not required, but that they should submit engineering certification for the dam upon completion.
09/08/2016	The Shire seeks independent legal advice from lawyers in regard to the history of the development.
29/08/2016	Shire receives advice from Jackson-McDonald regarding the reconstruction of the dam. The advice suggests that the earthworks / embankment retaining walls constitute "development" under the Planning and Development Act 2005 and therefore requires development approval.
9/09/2016	CEO writes to the landowners, advising that the Shire had sought independent legal advice and that staff have subsequently been advised that, despite the Shire's earlier advice, the earthworks that had been undertaken on the property, are works (development) that require approval under the Scheme. The owners were given until 3 October 2016 to submit an application for retrospective approval.

Date	Item
31/10/2016	Shire receives certification from a consulting engineer regarding the structural integrity of the dam wall.
10/2016	Matter is held in abeyance due to trauma experienced in the landowners' family .
24/10/2017	Application for retrospective development approval received.
3/11/2017	Application referred for neighbour consultation.
17/11/2017	Consultation closes – 2 objections received.
1/12/2017	Council Report drafted.

A feature survey of the dam including aerial photographs of the existing dam are attached. Refer Attachment 2 – Feature Survey and Attachment 3 – Aerial Images.

CONSIDERATIONS

Strategic Community / Corporate Business Plan

Theme Area 6: Governance & Leadership

Outcome 6.3: The Shire of Northam council is a sustainable, responsive, innovative and transparent organisation.

- Encourage active community participation in our local government.

Financial / Resource Implications

There are no financial implications for the Shire in relation to the recommendations of this report.

Legislative Compliance

Shire of Northam Local Planning Scheme No.6

Clause	Criteria	LPP / Scheme Provision	Proposed by Development	Criteria Met / Condition Required
LPS6, 3.2.1	Zone Objectives	Maintain and enhance the residential character and amenity of the zone.	Dam for personal recreation purposes on large low-density (R2.5) Residential zoned lot.	Yes.
LPS6, 4.5.2	Site & development standards and requirements	Compliance with development standards to ensure scale, nature, design, general appearance and impact of any proposed use is compatible with the objectives of the zone.	Earthworks associated with construction of a man-made dam.	Yes. Condition recommended.

Clause	Criteria	LPP / Scheme Provision	Proposed by Development	Criteria Met / Condition Required
LPS6, 4.11	Retaining walls	No retaining or filling to alter contours of the natural surface by more than 0.5m without development approval	Dam wall approximately 3m high.	Condition recommended.

Planning and Development (Local Planning Schemes) Regulations 2015

Clause	Criteria	LPP / Scheme Provision	Proposed by Development	Criteria Met / Condition Required
LPS Reg. 67(m)	Compatibility of development	Relationship of development	Earthworks associated with construction of a man-made dam. Height, bulk, scale and appearance of development unlikely to have a detrimental effect on adjoining land if dam outlet is altered to lower level when at capacity.	Condition to be imposed regarding modification of spillway.
LPS Reg. 67(n)	Amenity of the locality	Environmental impacts, character of locality & social impacts	Environmental - current water levels of dam causes marshy conditions on Lot 344 (25) Brockman Street.	Condition to be imposed regarding modification of spillway.
LPS Reg. 67(o)	Environmental impacts	Effect of development of natural environment and water sources.		Condition to be imposed requiring modification of downstream earthworks
LPS Reg. 67(r)	Suitability of the land for the development	Possible risk to human health or safety	Certification from a structural engineer suggest dam wall structure will be structurally sound and fit for purpose	Criterion met.
LPS Reg. 67(y)	Submissions received	Application advertising to adjoining landowners.	Two submissions were received raising concerns about the proposal.	Conditions can be imposed. Refer to Comments section of Report.

Policy Implications

There are no policy implications associated with this proposal.

Stakeholder Engagement / Consultation

The application was advertised for neighbour consultation for a period of 2 weeks from 3rd November 2017 until 17th November 2017.

Two (2) objections were received during the advertising period. A copy of the Schedule of Submissions is attached. Refer Attachment 4 – Schedule of Submissions.

Risk Implications

There are no risk implications for the Shire of the recommendations of this report provided appropriate conditions are attached to any approval that is granted to establish and manage the use and development.

OFFICER'S COMMENT

The application has been assessed in accordance with the provisions of the Shire's Scheme.

The history of the dam and its associated earthworks has been complicated and involved a number of different issues that have resulted in the matter being referred to Council for determination.

The matter has been somewhat complicated by the fact that the initial advice from Council staff was that development approval was not required.

Provided the conditions recommended are imposed it is believed the existing development can remain with minimal impact on the adjoining properties.

RECOMMENDATION

That Council grant retrospective Development Approval in accordance with the provisions of Shire of Northam Local Planning Scheme No. 6 to the landowner, Teneale Ann Kearney, for earthworks associated with the construction of a man-made dam at Lot 237 Brockman Street, Bakers Hill as outlined in the Application received 24 October 2017 (Application No. P17100), subject to the following conditions:

Conditions to be met within 2 months of the approval

1. The spillway of the dam be modified to a lower level determined in **consultation with Council's Executive Manager Engineering Services** to ensure that no water ponds on adjoining property;
2. A geotechnical report of the internal and external structural features of the dam be prepared by a suitably qualified engineer (at the cost of the landowner) and submitted for approval by **Council's Executive Manager Engineering Services** within two (2) months of this approval.
3. The spillway and earthworks on the property be modified to ensure that no water enters onto the downstream property from the spillway.

Attachment 1



Location Plan: 236-237 Brockman Street, Bakers Hill (2015 Image Landgate) - BEFORE

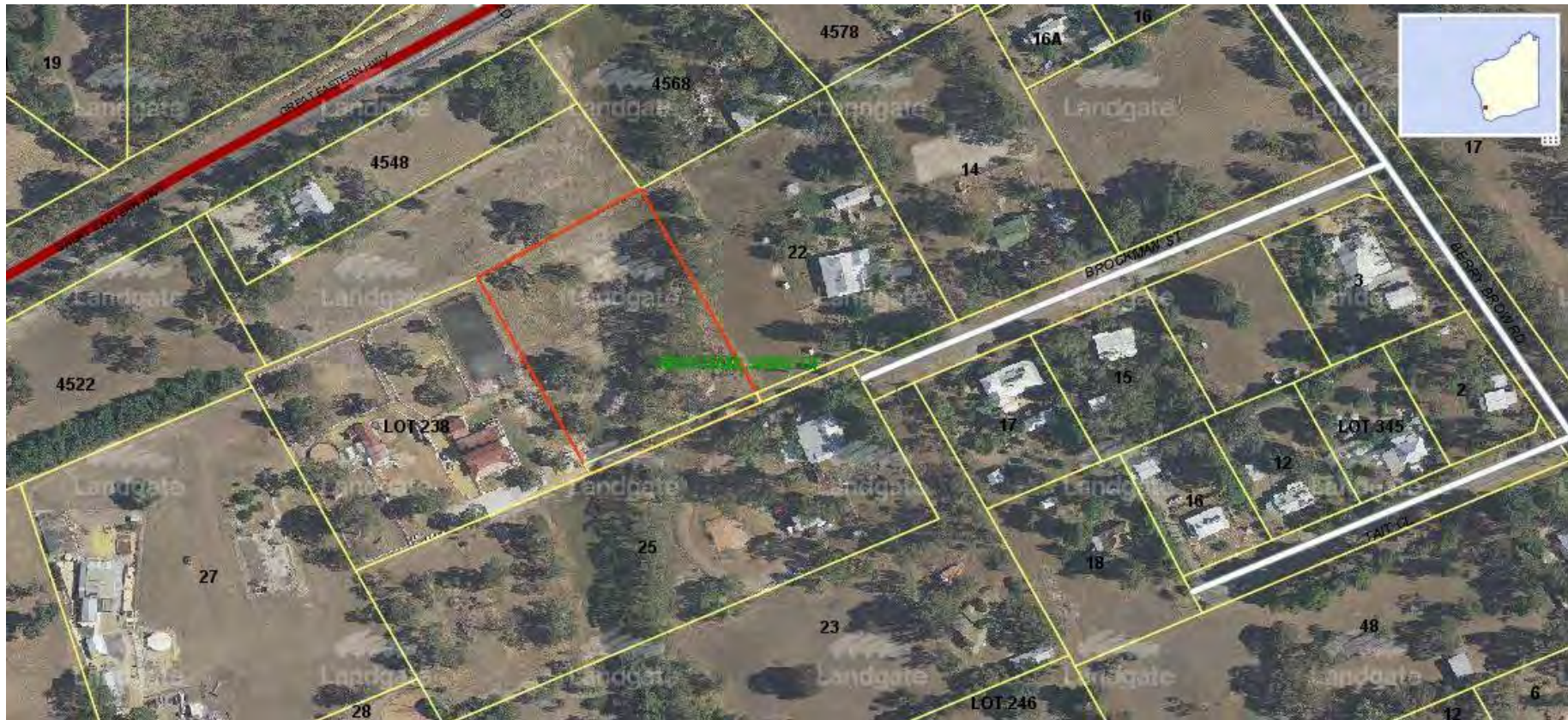



Location Plan: 236-237 Brockman Street, Bakers Hill (2017 Image - Landgate) - AFTER



Attachment 2

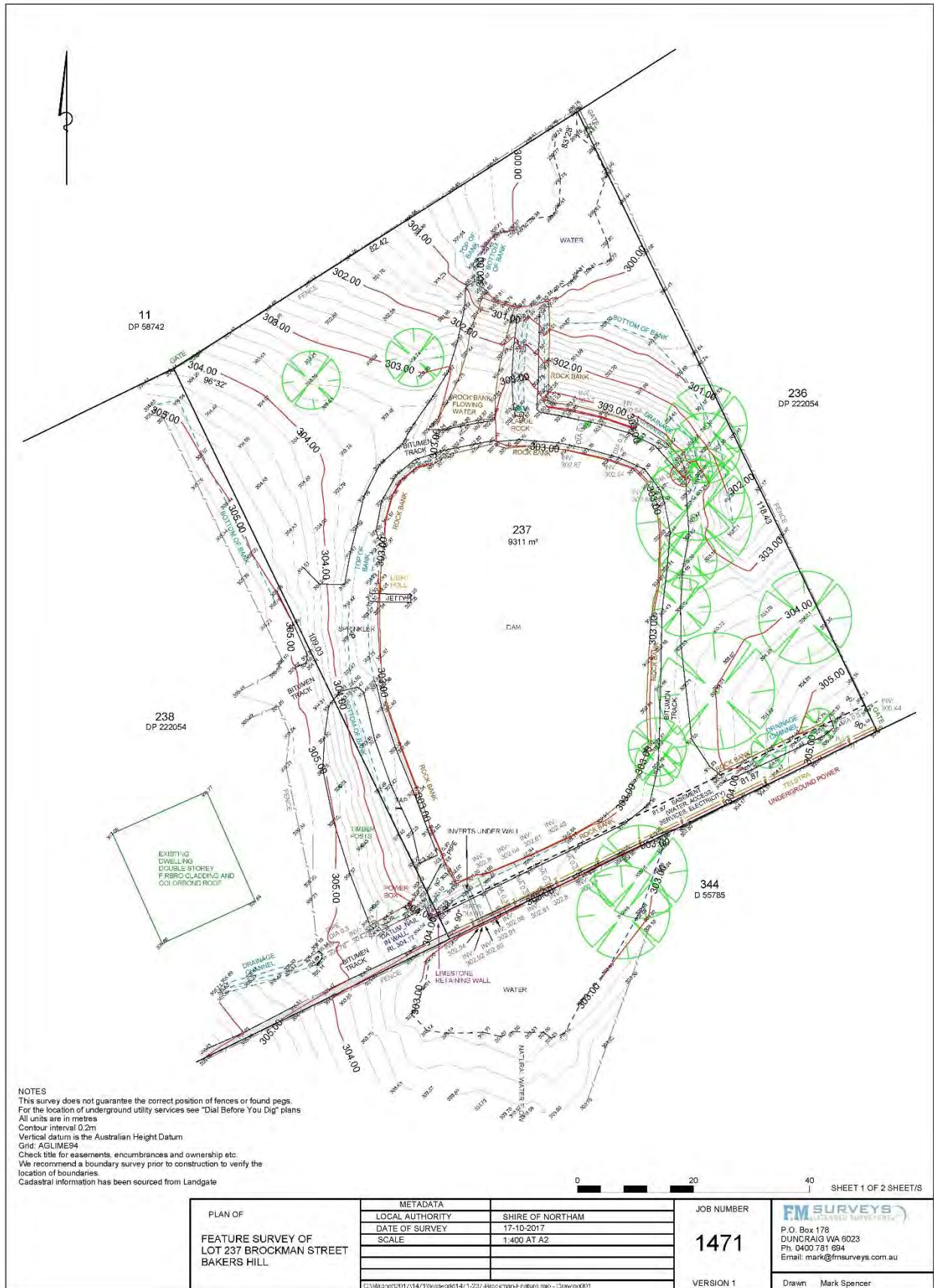



Attachment 3

Shire of Northam Local Planning Scheme No.6				
Application for retrospective development approval for earthworks associated with a man-made dam at Lot 237 Brockman Street, Bakers Hill				
Schedule of Submissions				
Number	Name	Summary of Submission	Key Themes Identified in Submission	Officer Comments and recommendations
1	WS Black & MJ Hartley	<p>Objection:</p> <ul style="list-style-type: none"> Dam has impacted the natural water flow and led to constant flooding and the damming of their property situated at 25 Brockman Street. Alleges that the existing site conditions has devalued their property and the affected portion of the property is unsightly to look at. Claims the dam is not adequately fenced off and the dam has breached previously. Have had to fence off the portion of the creek which has materially affected the owners' use of the land for horses for which was the intended purpose the land was purchased for. 	<p><i>Amenity & Use Impact</i></p> <p><i>Amenity & Use Impact</i></p> <p><i>Environmental Impact (Vegetation & Hydrology)</i></p>	<p>Noted. Loss of property value and fencing of the dam are non-material planning considerations. Recommendation: Modification of application not required.</p> <p>Noted. The wall height of the dam and spillway should be reduced to prevent backing up of water on the objectors' property. Recommendation: Impose condition on any approval to mitigate any impact the dam may have on adjoining properties.</p> <p>Noted. The wall height of the dam and spillway should be reduced to prevent</p>

Shire of Northam Local Planning Scheme No.6				
Application for retrospective development approval for earthworks associated with a man-made dam at Lot 237 Brockman Street, Bakers Hill				
Schedule of Submissions				
Number	Name	Summary of Submission	Key Themes Identified in Submission	Officer Comments and recommendations
		<ul style="list-style-type: none"> Concerned regarding the hydrological loading on our land and the impact this has had, including the loss of trees & natural/native grasses in the area and mud/silt build-up. The creek area used to dry through seasonal variation and does not dry in summer as a result of the dam; implied impact to local runoff and flows to Clackline Brook (connecting to Avon River). Concerned regarding the potential for mosquito establishment in the dam and the potential health risk. Lack of consultation regarding the construction of the dam 	<p><i>Environmental Impact (Public Health)</i></p> <p><i>Public Consultation</i></p> <p><i>Non-Compliance (Local Planning Scheme No.6)</i></p>	<p>backing up of water on the objectors' property. Recommendation: Impose condition on any approval to mitigate any impact the dam may have on adjoining properties.</p> <p>Noted. A Council officer has visited the neighbouring property to check if this is a source of mosquito breeding however but could find no evidence on the day. Officers are of the view that there is still the potential for mosquito breeding if the wall height and spillway is not reduced to prevent the water backing up. Recommendation: Impose condition on any approval to mitigate any impact the dam may have on adjoining properties.</p>

Shire of Northam Local Planning Scheme No.6 Application for retrospective development approval for earthworks associated with a man-made dam at Lot 237 Brockman Street, Bakers Hill Schedule of Submissions				
Number	Name	Summary of Submission	Key Themes Identified in Submission	Officer Comments and recommendations
		<p>by either the applicant or the Shire and the lack of technical information being supplied regarding the development.</p> <ul style="list-style-type: none"> Concerned regarding the permissibility of the dam in a residential zone, and the applicants non-conformance with Shire of Northam Local Planning Scheme No.6 regarding height allowances for earthworks/wall height. 		<p>Noted. The purpose of the retrospective planning application by the applicant involves providing for the processes noted. Recommendation: Modification of application not required.</p> <p>Noted. Local Planning Scheme No.6 does not have controls related to the development of dams on land zoned residential within the Shire of Northam. Section 4.11.1 of Local Planning Scheme No.6 indicates development approval is required for the altering of the natural surface by more than 0.5m which is the subject of the retrospective development application. Recommendation: Modification of application not required.</p>
2	BM Bryan	<p>Objection:</p> <ul style="list-style-type: none"> The location of the dam and altered land height has impacted the watercourse, 	<i>Hydrology Impact</i>	<p>Noted. Agree. Recommendation: Impose condition on any approval to mitigate any</p>

Shire of Northam Local Planning Scheme No.6 Application for retrospective development approval for earthworks associated with a man-made dam at Lot 237 Brockman Street, Bakers Hill Schedule of Submissions				
Number	Name	Summary of Submission	Key Themes Identified in Submission	Officer Comments and recommendations
		<p>increasing flooding and runoff onto L11 Great Eastern Highway, where previously no impact existed (watercourse ran along boundary rather than into lot).</p> <ul style="list-style-type: none"> • Impact on site drainage of the land and excavation in proximity to property boundary increasing the potential for land movement and instability. • The construction has affected public safety within the immediate area and surrounds. • A non-compliant electric fence on the applicant's property, with previous damage to this fence through a prior breach of the dam wall providing access to dam and spillway and potential for drowning. 	<p><i>Hydrogeology Impact</i></p> <p><i>Environmental Impact (Public Health)</i></p>	<p>impact the dam may have on adjoining properties.</p> <p>Noted. Local Planning Scheme No.6 does not have controls related to the development of dams on land zoned residential within the Shire of Northam.</p>

Shire of Northam Local Planning Scheme No.6				
Application for retrospective development approval for earthworks associated with a man-made dam at Lot 237 Brockman Street, Bakers Hill				
Schedule of Submissions				
Number	Name	Summary of Submission	Key Themes Identified in Submission	Officer Comments and recommendations
		<ul style="list-style-type: none"> The construction of the dam has increased the potential safety impact to users of Great Eastern Highway. The increase in mosquitos has also created the potential for a public health hazard. Potential for water contamination due to the proximity of the sewerage of local residents. Environmental impact through dam breach (March 2016) with debris and silt deposition on L11 Great Eastern Highway, and the loss of existing vegetation and introduction of other species through flooding. The water logging of the property resulting from the dam, and the death of trees on the natural water course and the removal of significant 	<p><i>Environmental Impact (Vegetation & Hydrology)</i></p> <p><i>Nuisance/Amenity & Use Impact</i></p>	<p>Partially dismissed. Not a valid planning consideration, is relevant to Building Permit process which may/may not occur as a result of a planning determination.</p>

Shire of Northam Local Planning Scheme No.6 Application for retrospective development approval for earthworks associated with a man-made dam at Lot 237 Brockman Street, Bakers Hill Schedule of Submissions				
Number	Name	Summary of Submission	Key Themes Identified in Submission	Officer Comments and recommendations
		<p>vegetation by the applicant in the creation of the dam.</p> <ul style="list-style-type: none"> • The proposal is located in a R10 zone, and continues to impact myself through risk posed by the dam and activities by the applicant. • Raised concerns with the Shire of Northam (ICS58704 – A15884). • The depositing of earthen wall on L11 Great Eastern Highway (during dam construction) by applicant to divert water leaching from dam and spillway across L11 Great Eastern Highway). • Continued maintenance activities of applicant pumping water across L11 at various times without consent (water flows downhill). • Loss of fences on L11 as a result of dam breach (March 2016). 	<p><i>Non-Compliance (Building Act 2011)</i></p>	<p>Partially dismissed. Shire of Northam Local Planning Strategy does not inform development requirements. Local Planning Scheme No.6 does not have controls related to the development of dams on land zoned residential within the Shire of Northam. Section 4.11.1 of Local Planning Scheme No.6 indicates development approval is required for the altering of the natural surface by more than 0.5m which is the subject of the retrospective development application.</p> <p>Noted. SPP 2.9 notes to aim to prevent or ameliorate the following impacts which are applicable to the proposal:</p> <ul style="list-style-type: none"> • any potential adverse effects on environmental water requirements and, as a minimum, proposed

Shire of Northam Local Planning Scheme No.6				
Application for retrospective development approval for earthworks associated with a man-made dam at Lot 237 Brockman Street, Bakers Hill				
Schedule of Submissions				
Number	Name	Summary of Submission	Key Themes Identified in Submission	Officer Comments and recommendations
		<ul style="list-style-type: none"> • Continued risk of a further breach of the dam, and the diminished use of L11 due to the dam, devaluing the property. • No consent sought by applicant before doing specified work (Building Act 2011) as per Shire of Northam guidance note regarding "Work Affecting Other Land" which has affected adjoining land. • The works form an 'incidental structure', and therefore the following breaches have occurred under the Building Act: <ul style="list-style-type: none"> ○ No building work without a building permit; ○ Requirement to prepare and submit application; ○ Certificate of design compliance required; 	<p><i>Non-Compliance (Local Planning Scheme No.6)</i></p> <p><i>Non-Compliance (State Planning Policy 2.9)</i></p> <p><i>Non-Compliance (ANCOLD)</i></p>	<p>development should aim to maintain natural flow regimes and variability;</p> <p>Dismissed. Not a valid planning consideration.</p>

Shire of Northam Local Planning Scheme No.6 Application for retrospective development approval for earthworks associated with a man-made dam at Lot 237 Brockman Street, Bakers Hill Schedule of Submissions				
Number	Name	Summary of Submission	Key Themes Identified in Submission	Officer Comments and recommendations
		<ul style="list-style-type: none"> o Other land not being adversely affected without consent/court order or other authority; o No protection structure in or on other land without consent/court order or other authority; o No access to other land without consent, court order & notification or other authority; o Notice concerning effect of on other land required; o Form and consent of notice about effect on other land; <ul style="list-style-type: none"> • Contradicts requirements and strategies as set out in Shire of Northam Local Planning Scheme No.6 & Shire of Northam Local Planning Strategy (2013). 		

Shire of Northam Local Planning Scheme No.6				
Application for retrospective development approval for earthworks associated with a man-made dam at Lot 237 Brockman Street, Bakers Hill				
Schedule of Submissions				
Number	Name	Summary of Submission	Key Themes Identified in Submission	Officer Comments and recommendations
		<ul style="list-style-type: none"> • Contradicts requirements and strategies as set out in State Planning Policy 2.9 Water Resources (2006) • Is not constructed or designed in accordance with the Australian National Committee on Large Dams Incorporated (ANCOLD) including the preparation risk assessment. This includes maintaining dam safety remedial works program to reduce the risk of dam failure; this has not been prepared nor any restriction on the dams use been prepared. 		

12.4 CORPORATE SERVICES

12.4.1 Accounts & Statements of Accounts - November 2017

Address:	N/A
Owner:	N/A
File Reference:	2.1.3.4
Reporting Officer:	Creditors Officer Kathy Scholz
Responsible Officer:	Colin Young Executive Manager Corporate Services
Voting Requirement	Simple Majority

BRIEF

For Council to receive the accounts for the period from 1st November 2017 to 30th November 2017.

ATTACHMENTS

Attachment 1: Accounts & Statements of Accounts – November 2017.

Attachment 2: Declaration.

BACKGROUND / DETAILS

The reporting of monthly financial information is a requirement under section 6.4 of the Local Government Act 1995, and Regulation 34 of the Local Government (Financial Management) Regulations.

Pursuant to Financial Management Regulation 13, a list of payments made from Municipal and Trust accounts is required to be presented to Council on a periodical basis. These details are included as Attachment 1. In accordance with Financial Management Regulation 12, the Chief Executive Officer has delegated authority to make these payments.

CONSIDERATIONS

Strategic Community / Corporate Business Plan

Theme Area 6: Governance & Leadership.

Outcome 6.3: The Shire of Northam council is a sustainable, responsive, innovative and transparent organisation.

Financial / Resource Implications

Payments of accounts are in accordance with Council's 2017/18 Budget.

Legislative Compliance

Section 6.4 of the Local Government Act

Financial Management Regulations 2007 9

Section 6.26(2)(g) of the Local Government Act 1995

Policy Implications

Nil.

Stakeholder Engagement / Consultation

Not applicable.

Risk Implications

Nil.

OFFICER'S COMMENT

The matter of Council 'supporting local business' has been raised over a long period. To assist in providing a greater understanding of the purchasing patterns of the Shire of Northam, the following graph summarises the payments made locally for the month of November 2017;

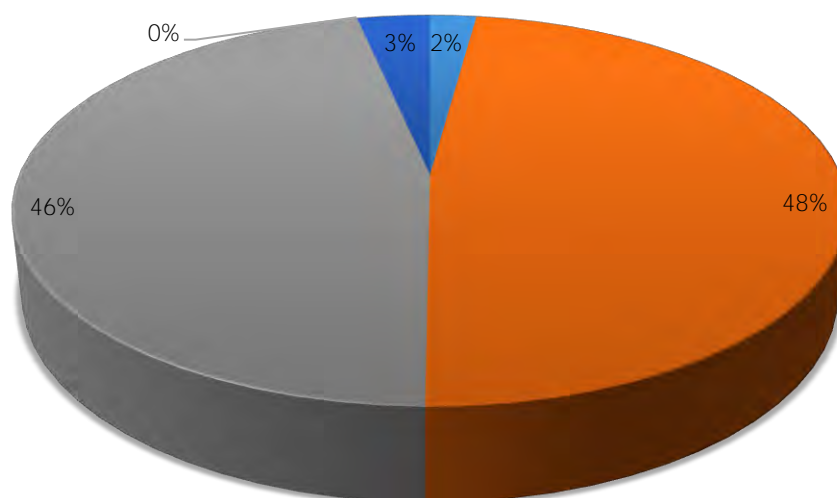

- Staff Expenses
- Purchased from Shire of Northam Businesses or Individuals
- No Organisation or Business in Shire of Northam that can offer service required
- Purchase from Businesses or Individuals outside Shire of Northam
- Contract has gone to Tender

RECOMMENDATION

That Council endorse the payments for the period 1st November 2017 to 30th November 2017, as listed, which have been made in accordance with the delegated authority reference number (M/F/F/Regs LGA 1995 S5.42).

Attachment 1

Date: 01/12/2017
Time: 9:08:54AM

Shire of Northam

USER: Kathy Scholz
PAGE: 1

Cheque / EFT No	Date	Name	Invoice Description	Bank Code	INV Amount	Amount
2027	14/11/2017	SHIRE OF NORTHAM	PAYMENT FOR COLLECTION OF BSL FEES ON BEHALF OF THE CONSTRUCTION TRAINING FUND FOR THE MONTH OF OCTOBER 2017.	2		194.25
INV T994	14/11/2017	SHIRE OF NORTHAM	PAYMENT FOR COLLECTION OF BCITF FEES ON BEHALF OF THE CONSTRUCTION TRAINING FUND FOR THE MONTH OF OCTOBER 2017.	2	74.25	
INV T995	14/11/2017	SHIRE OF NORTHAM	PAYMENT FOR COLLECTION OF BSL FEES ON BEHALF OF THE CONSTRUCTION TRAINING FUND FOR THE MONTH OF OCTOBER 2017.	2	120.00	
2028	22/11/2017	BRETT ANTHONY JOHNSON	REFUND OF 2017 ELECTION NOMINATIONS.	2		80.00
INV T1007	22/11/2017	BRETT ANTHONY JOHNSON	REFUND OF 2017 ELECTION NOMINATIONS.	2	80.00	
2029	22/11/2017	BRIDGETTE ALANA POULTON	REFUND OF 2017 ELECTION NOMINATION.	2		80.00
INV T1012	22/11/2017	BRIDGETTE ALANA POULTON	REFUND OF 2017 ELECTION NOMINATION.	2	80.00	
2030	22/11/2017	EARNEST ERVIN	REFUND OF 2017 ELECTION NOMINATIONS.	2		80.00
INV T1014	22/11/2017	EARNEST ERVIN	REFUND OF 2017 ELECTION NOMINATIONS.	2	80.00	
2031	22/11/2017	HUDSON'S CIRCUS	REFUND OF BOND ON JUBILEE OVAL FOR CIRCUS - 8-11 NOVEMBER 2017 - BOOKING #3094.	2		100.00
INV T1023	22/11/2017	HUDSON'S CIRCUS	REFUND OF BOND ON JUBILEE OVAL FOR CIRCUS - 8-11 NOVEMBER 2017 - BOOKING #3094.	2	100.00	
2032	22/11/2017	SANDRA-LEE WELCH	REFUND FROM 2017 ELECTION NOMINATIONS.	2		80.00
INV T1013	22/11/2017	SANDRA-LEE WELCH	REFUND FROM 2017 ELECTION NOMINATIONS.	2	80.00	
EFT28101	03/11/2017	SPECIALISED TREE SERVICE	PRUNE NORTHAM TOWNSITE STREET TREES AS PER CONTRACT 19 OF 2015	1		13,461.50
INV 2655	27/10/2017	SPECIALISED TREE SERVICE	CONTRACT VARIATION#1 PRUNE NORTHAM TOWNSITE STREET TREES AS PER CONTRACT 19 OF 2015	1	13,461.50	
EFT28102	03/11/2017	ABBOTTS FORGE	REPAIR TIMBER BRIDGE AND HANDRAILS AT LEADER BRIDGE AS PER QUOTATION 2711	1		5,465.00

Date: 01/12/2017
Time: 9:08:54AM

Shire of Northam

USER: Kathy Scholz
PAGE: 2

Cheque / EFT No	Date	Name	Invoice Description	Bank Code	INV Amount	Amount
INV 0000271127/10/2017		ABBOTTS FORGE	REPAIR TIMBER BRIDGE AND HANDRAILS AT LEADER BRIDGE AS PER QUOTATION 2711	1	5,465.00	
EFT28103	03/11/2017	ALYSON MCMAHON	REIMBURSEMENT FOR POLICE CLEARANCE APPLICATION	1		49.50
INV 1711010901/11/2017		ALYSON MCMAHON	REIMBURSEMENT FOR POLICE CLEARANCE APPLICATION	1	49.50	
EFT28104	03/11/2017	AUSTRALIAN SERVICES UNION	Payroll deductions	1		27.45
INV DEDUCT31/10/2017		AUSTRALIAN SERVICES UNION	Payroll deductions		27.45	
EFT28105	03/11/2017	AUSTRALIAN TAXATION OFFICE - PAYG	PAYG PAY RUN WEEK ENDING 31/10/2017 & INTERIM P/RUN 26/10/2017	1		61,312.01
INV PAYG 3131/10/2017		AUSTRALIAN TAXATION OFFICE - PAYG	PAYG PAY RUN WEEK ENDING 31/10/2017 & INTERIM P/RUN 26/10/2017	1	61,312.01	
EFT28106	03/11/2017	AVON DEMOLITION & EARTHMOVING	MANAGEMENT OF INKPEN ROAD WASTE MANAGEMENT FACILITY.	1		1,568.00
INV 0065	22/10/2017	AVON DEMOLITION & EARTHMOVING	MANAGEMENT OF INKPEN ROAD WASTE MANAGEMENT FACILITY.	1	1,568.00	
EFT28107	03/11/2017	AVON TELECOMS PTY LTD	ADMIN BUILDING. RELOCATE AND PATCH	1		495.00
INV 0000449820/06/2017		AVON TELECOMS PTY LTD	ADMIN BUILDING. RELOCATE AND PATCH	1	297.00	
INV 0000460119/09/2017		AVON TELECOMS PTY LTD	SERVICE CALL TO CONNECT UP CONFERENCE ROOM	1	198.00	
EFT28108	03/11/2017	AVON VALLEY CONTRACTORS	SEMI WATER TRUCK HIRE	1		3,192.75
INV 2023	20/10/2017	AVON VALLEY CONTRACTORS	SEMI WATER TRUCK HIRE	1	3,192.75	
EFT28109	03/11/2017	AVON VALLEY PLANT & EQUIPMENT PTY LTD	REPLACE 30M OF CONCRETE FOOTPATH & KERB AT APEX PARK SIDE.	1		7,381.00
INV IV10163	14/09/2017	AVON VALLEY PLANT & EQUIPMENT PTY LTD	REPLACE 30M OF CONCRETE FOOTPATH & KERB AT APEX PARK SIDE.	1	7,381.00	
EFT28110	03/11/2017	AVON WASTE	DOMESTIC & COMMERCIAL RUBBISH COLLECTION IN THE SHIRE OF NORTHAM FOR THE FORTNIGHT ENDING 29/09/2017.	1		177,965.73

Date: 01/12/2017
Time: 9:08:54AM

Shire of Northam

USER: Kathy Scholz
PAGE: 3

Cheque / EFT No	Date	Name	Invoice Description	Bank Code	INV Amount	Amount
INV CY2510225/10/2017		AVON WASTE	SCRAP METAL MONEY FROM AAA METALS WAS ACCIDENTLY PAID TO SHIRE OF NORTHAM INSTEAD OF AVON WASTE GET MONEY FROM OLD QUARRY RD LANDFILL AS PER CONTRACT	1	20,879.76	
INV 26533	29/09/2017	AVON WASTE	DOMESTIC & COMMERCIAL RUBBISH COLLECTION IN THE SHIRE OF NORTHAM FOR THE FORTNIGHT ENDING 29/09/2017.	1	83,582.21	
INV 26563	13/10/2017	AVON WASTE	DOMESTIC & COMMERCIAL RUBBISH COLLECTION IN THE SHIRE OF NORTHAM FOR THE FORTNIGHT ENDING 13/10/2017.	1	37,251.86	
INV 25029	09/06/2017	AVON WASTE	DOMESTIC & COMMERCIAL RUBBISH COLLECTION IN THE SHIRE OF NORTHAM FOR THE FORTNIGHT ENDING 09/06/2017.	1	36,251.90	
EFT28111	03/11/2017	AWP GROUP	90% DEPOSIT TO MANUFACTURE SUPPLY & INSTALL HIP ROOF SHADE STRUCTURES AT DR DUNLOP PARK, FREIND PLACE PARK & MAY STREET PARK (DIDNT PAY CORRECT AMOUNT PREVIOUSLY MISSED THE GST COMPONENT \$4085.55)	1		4,085.55
INV INV-014809/10/2017		AWP GROUP	90% DEPOSIT TO MANUFACTURE SUPPLY & INSTALL HIP ROOF SHADE STRUCTURES AT DR DUNLOP PARK, FREIND PLACE PARK & MAY STREET PARK (DIDNT PAY CORRECT AMOUNT PREVIOUSLY MISSED THE GST COMPONENT \$4085.55)	1	4,085.55	
EFT28112	03/11/2017	BAKERS HILL VETERINARY HOSPITAL	CAT CASTRATION & MICROCHIP	1		150.00
INV 31794	19/10/2017	BAKERS HILL VETERINARY HOSPITAL	(SUBSIDY) CAT CASTRATION & MICROCHIP (SUBSIDY)	1	150.00	
EFT28113	03/11/2017	BEAUREPAINES	TYRE FOR PNI513 - Z TRACK MOWER	1		179.47
INV U524347/07/10/2017		BEAUREPAINES	TYRE FOR PNI513 - Z TRACK MOWER	1	179.47	
EFT28114	03/11/2017	BLACKWELL PLUMBING PTY LTD	MAYSTREET RESERVE. BACKFLOW TESTS ON 2 X DEVICES.	1		528.00
INV INV-168613/10/2017		BLACKWELL PLUMBING PTY LTD	MAYSTREET RESERVE. BACKFLOW TESTS ON 2 X DEVICES.	1	264.00	
INV INV-168513/10/2017		BLACKWELL PLUMBING PTY LTD	BACKFLOW TESTING AT JUBILEE OVAL	1	264.00	
EFT28115	03/11/2017	BOOTH PRINT	STOCK PURCHASES FOR VISITORS CENTRE	1		1,842.50

Date: 01/12/2017
Time: 9:08:54AM

Shire of Northam

USER: Kathy Scholz
PAGE: 4

Cheque / EFT No	Date	Name	Invoice Description	Bank Code	INV Amount	Amount
INV 8798	25/10/2017	BOOTH PRINT	STOCK PURCHASES FOR VISITORS CENTRE	1	1,452.00	
INV 8786	26/10/2017	BOOTH PRINT	4 X SWIMMING POOL INSPECTION BOOKS AS PER QUOTE NUMBER 8786	1	390.50	
EFT28116	03/11/2017	CASCADA	2 X 750KG PLAIN APRONS, 1 X 747KG LEFT APRON, 3 X 140KG SIDE ENTRY FRAMES, 3 X 105KG SIDE ENTRY LIDS & DELIVERY FROM MALAGA TO NORTHAM.	1		3,075.60
INV 3088	27/09/2017	CASCADA	2 X 750KG PLAIN APRONS, 1 X 747KG LEFT APRON, 3 X 140KG SIDE ENTRY FRAMES, 3 X 105KG SIDE ENTRY LIDS & DELIVERY FROM MALAGA TO NORTHAM.	1	2,453.00	
INV 3360	26/10/2017	CASCADA	DEFLECTOR SLAB FOR MINSON AVENUE	1	622.60	
EFT28117	03/11/2017	CENTRAL REGIONAL TAFE	AUH 20 - DEVELOP AND USE COMPLEX SPREADSHEETS	1		494.45
INV 1000224915/08/2017		CENTRAL REGIONAL TAFE	AUH 20 - DEVELOP AND USE COMPLEX SPREADSHEETS	1	353.90	
INV 10002201 10/08/2017		CENTRAL REGIONAL TAFE	ACCOUNTING BOOKS FOR JODI WHITE.	1	140.55	
EFT28118	03/11/2017	COUNTRY COMFORTSTYLE NORTHAM	WORKSTATION & HUTCH FOR KILLARA MANAGER OFFICE	1		898.00
INV 4001	11/10/2017	COUNTRY COMFORTSTYLE NORTHAM	WORKSTATION & HUTCH FOR KILLARA MANAGER OFFICE	1	898.00	
EFT28119	03/11/2017	COURIER AUSTRALIA	FREIGHT CHARGES FOR DEPOT & ADMIN FOR W/E 20/10/2017.	1		219.53
INV 0326	20/10/2017	COURIER AUSTRALIA	FREIGHT CHARGES FOR DEPOT & ADMIN FOR W/E 20/10/2017.	1	219.53	
EFT28120	03/11/2017	COVS PARTS PTY LTD	ASSORTED CABLE TIES FOR BFB.	1		362.98
INV 1690010909/05/2017		COVS PARTS PTY LTD	ASSORTED CABLE TIES FOR BFB.	1	362.98	
EFT28121	03/11/2017	DEPARTMENT OF PRIMARY INDUSTRIES AND REGIONAL DEVELOPMENT	ROOM HIRE AND CATERING - INNOVATION HUB CONCEPT WORKSHOP 20 OCTOBER 2017	1		129.70
INV 7131959 24/10/2017		DEPARTMENT OF PRIMARY INDUSTRIES AND REGIONAL DEVELOPMENT	ROOM HIRE AND CATERING - INNOVATION HUB CONCEPT WORKSHOP 20 OCTOBER 2017	1	129.70	
EFT28122	03/11/2017	E. & M.J. ROSHER PTY LTD	PARTS FOR PN1005.	1		228.50
INV 1107469 20/10/2017		E. & M.J. ROSHER PTY LTD	PARTS FOR PN1005.	1	228.50	
EFT28123	03/11/2017	EASIFLEET	Payroll deductions	1		1,064.47

Date: 01/12/2017
Time: 9:08:54AM

Shire of Northam

USER: Kathy Scholz
PAGE: 5

Cheque / EFT No	Date	Name	Invoice Description	Bank Code	INV Amount	Amount
INV DEDUCT31/10/2017		EASIFLEET	Payroll deductions		783.95	
INV DEDUCT31/10/2017		EASIFLEET	Payroll deductions		280.52	
EFT28124	03/11/2017	FULTON HOGAN INDUSTRIES PTY LTD	IT BULKA BAG COLDMIX FOR ROAD MAINTENANCE.	1		2,816.00
INV 1103208105/10/2017		FULTON HOGAN INDUSTRIES PTY LTD	IT BULKA BAG COLDMIX FOR ROAD MAINTENANCE.	1	2,816.00	
EFT28125	03/11/2017	GLENN STUART BEVERIDGE	REC CENTRE. REPAIR DROP BOLT TO	1		297.00
INV 516	23/10/2017	GLENN STUART BEVERIDGE	REC CENTRE. REPAIR DROP BOLT TO	1	297.00	
EFT28126	03/11/2017	HAYS SPECIALIST RECRUITMENT (AUSTRALIA) PTY LIMITED	RECRUITMENT SERVICES	1		44,967.86
INV 6855887	13/09/2017	HAYS SPECIALIST RECRUITMENT (AUSTRALIA) PTY LIMITED	RELIEF BUILDING SURVEYOR - 5-7TH AND 26-28TH	1	2,741.48	
INV 6904656	04/10/2017	HAYS SPECIALIST RECRUITMENT (AUSTRALIA) PTY LIMITED	RELIEF BUILDING SURVEYOR W/E 01/10/2017.	1	2,741.48	
INV 6855884	13/09/2017	HAYS SPECIALIST RECRUITMENT (AUSTRALIA) PTY LIMITED	LABOUR HIRE - ADRIAN MUNCKTON - W/E 10/09/2017.	1	1,342.77	
INV 6871617	20/09/2017	HAYS SPECIALIST RECRUITMENT (AUSTRALIA) PTY LIMITED	LABOUR HIRE ADRIAN MUNCKTON W/E 17/9/2017.	1	1,466.72	
INV 6887874	27/09/2017	HAYS SPECIALIST RECRUITMENT (AUSTRALIA) PTY LIMITED	LABOUR HIRE - ADRIAN MUNCKTON W/E 24/9/2017.	1	1,384.09	
INV 6904655	04/10/2017	HAYS SPECIALIST RECRUITMENT (AUSTRALIA) PTY LIMITED	ACTING WORKS SUPERVISOR GEOFFREY COPLEY - WEEK ENDING 24/9/2017.	1	2,982.19	
INV 6928839	17/10/2017	HAYS SPECIALIST RECRUITMENT (AUSTRALIA) PTY LIMITED	RECRUITMENT SERVICES - SAM NEALE	1	14,333.55	
INV 6904653	04/10/2017	HAYS SPECIALIST RECRUITMENT (AUSTRALIA) PTY LIMITED	LABOUR HIRE - ADRIAN MUNCKTON W/E 01/10/2017.	1	1,053.56	
INV 6904652	04/10/2017	HAYS SPECIALIST RECRUITMENT (AUSTRALIA) PTY LIMITED	LABOUR HIRE - MARK SCHNELL W/E 04/10/2017.	1	1,301.45	
INV 6855883	13/09/2017	HAYS SPECIALIST RECRUITMENT (AUSTRALIA) PTY LIMITED	LABOUR HIRE - MARK SCHNELL W/E 10/09/2017.	1	1,797.25	
INV 6936559	18/10/2017	HAYS SPECIALIST RECRUITMENT (AUSTRALIA) PTY LIMITED	ACTING WORKS SUPERVISOR GEOFFREY COPLEY FOR PERIOD WEEK ENDING 15/10/2017.	1	3,087.44	
INV 6952733	25/10/2017	HAYS SPECIALIST RECRUITMENT (AUSTRALIA) PTY LIMITED	ACTING WORKS SUPERVISOR GEOFRY COPLEY FOR PERIOD WEEK ENDING 22/10/2017.	1	2,982.19	
INV 6855885	13/09/2017	HAYS SPECIALIST RECRUITMENT (AUSTRALIA) PTY LIMITED	ACTING WORKS SUPERVISOR GEOFFREY COPLEY FOR PERIOD WEEK ENDING 10/9/2017.	1	3,017.27	

Date: 01/12/2017
Time: 9:08:54AM

Shire of Northam

USER: Kathy Scholz
PAGE: 6

Cheque / EFT No	Date	Name	Invoice Description	Bank Code	INV Amount	Amount
INV 6920533	11/10/2017	HAYS SPECIALIST RECRUITMENT (AUSTRALIA) PTY LIMITED	ACTING WORKS SUPERVISOR GEOFFREY COPLEY FOR PERIOD WEEK ENDING 8/10/2017	1	2,947.10	
INV 6904654	04/10/2017	HAYS SPECIALIST RECRUITMENT (AUSTRALIA) PTY LIMITED	ACTING WORKS SUPERVISOR GEOFFREY COPLEY FOR PERIOD WEEK ENDING 1/10/2017.	1	1,789.32	
EFT28127	03/11/2017	IXOM OPERATIONS PTY LTD	CHLORINE SERVICE FEE FOR THE PERIOD 01/10/2017 TO 31/10/2017.	1		348.50
INV 5890151	31/10/2017	IXOM OPERATIONS PTY LTD	CHLORINE SERVICE FEE FOR THE PERIOD 01/10/2017 TO 31/10/2017.	1	348.50	
EFT28128	03/11/2017	KLEENHEAT GAS	TOWN HALL. YEARLY GAS BOTTLE HIRE.	1		759.00
INV 4060147	01/06/2017	KLEENHEAT GAS	TOWN HALL. YEARLY GAS BOTTLE HIRE.	1	151.80	
INV 4080881	01/09/2017	KLEENHEAT GAS	TOWN HALL. YEARLY GAS BOTTLE HIRE.	1	607.20	
EFT28129	03/11/2017	LEON GEOFFREY CONWAY	REFUND FOR PLANNING DEVELOPMENT APPLICATION FEE (WAS PAID TWICE) P17037 EARTHWORKS	1		147.00
INV 101716	16/10/2017	LEON GEOFFREY CONWAY	REFUND FOR PLANNING DEVELOPMENT APPLICATION FEE (WAS PAID TWICE) P17037 EARTHWORKS	1	147.00	
EFT28130	03/11/2017	LOCAL GOVERNMENT AND RACECOURSE EMPLOYEES UNION	Payroll deductions	1		20.50
INV DEDUCT31/10/2017		LOCAL GOVERNMENT AND RACECOURSE EMPLOYEES UNION	Payroll deductions		20.50	
EFT28131	03/11/2017	LUCY'S TEAROOMS	CATERING FOR COUNCIL FORUM MEETING 14/12/2016.	1		250.00
INV 1438	21/06/2017	LUCY'S TEAROOMS	CATERING FOR COUNCIL FORUM MEETING 14/12/2016.	1	250.00	
EFT28132	03/11/2017	LYNDA BURKE	REFUND FOOD STALL APPLICATION AS IT WAS REJECTED AS NOT APPROVED MOBILE FOOD BUSINESS.	1		60.00
INV 107750	30/10/2017	LYNDA BURKE	REFUND FOOD STALL APPLICATION AS IT WAS REJECTED AS NOT APPROVED MOBILE FOOD BUSINESS.	1	60.00	
EFT28133	03/11/2017	MCLEODS BARRISTERS & SOLICITORS	UNLAWFUL USE OF PROPERTY	1		309.61
INV 99154	03/08/2017	MCLEODS BARRISTERS & SOLICITORS	UNLAWFUL USE OF PROPERTY	1	309.61	
EFT28134	03/11/2017	MICHELLE ZUCCHETTO	REIMBURSEMENT FOR POLICE CLEARANCE APPLICATION FOR TENAYA EWINGS.	1		50.00
INV RR0111201/11/2017		MICHELLE ZUCCHETTO	REIMBURSEMENT FOR POLICE CLEARANCE APPLICATION FOR TENAYA EWINGS.	1	50.00	

Date: 01/12/2017
Time: 9:08:54AM

Shire of Northam

USER: Kathy Scholz
PAGE: 7

Cheque / EFT No	Date	Name	Invoice Description	Bank Code	INV Amount	Amount
EFT28135	03/11/2017	MORRIS PEST AND WEED CONTROL	CLACKLINE HALL. TREAT TERMITES AS PER QUOTE 162.	1		1,048.50
INV 8384	19/10/2017	MORRIS PEST AND WEED CONTROL	CLACKLINE HALL. TREAT TERMITES AS PER QUOTE 162.	1	704.50	
INV 8380	19/10/2017	MORRIS PEST AND WEED CONTROL	KILLARA DAY CARE. SPRAY SPIDERS ON OUTSIDE OF BUILDING.	1	344.00	
EFT28136	03/11/2017	MR NATURALLY CLEAN	FIRE WATCH SECURITY CHARGES FOR THE PERIOD 08/10/2017 TO 10/10/2017 AT OLD QUARRY ROAD REFUSE SITE.	1		8,089.14
INV INV-042223/10/2017		MR NATURALLY CLEAN	FIRE WATCH SECURITY CHARGES FOR THE PERIOD 08/10/2017 TO 10/10/2017 AT OLD QUARRY ROAD REFUSE SITE.	1	6,373.14	
INV INV-040713/10/2017		MR NATURALLY CLEAN	SECURITY AT VARIOUS BUILDINGS FOR OCTOBER 2017.	1	1,716.00	
EFT28137	03/11/2017	NORTHAM & DISTRICTS GLASS SERVICE	RE CENTRE INSURANCE CLAIM. REPLACE 3 X BROKEN WINDOWS DUE TO VANDALISM.	1		1,556.50
INV 000223	11/10/2017	NORTHAM & DISTRICTS GLASS SERVICE	RE CENTRE INSURANCE CLAIM. REPLACE 3 X BROKEN WINDOWS DUE TO VANDALISM.	1	1,556.50	
EFT28138	03/11/2017	NORTHAM BOWLING CLUB INC	SENIOR SPORT FUNDING.	1		150.00
INV 7027	01/11/2017	NORTHAM BOWLING CLUB INC	SENIOR SPORT FUNDING.	1	150.00	
EFT28140	03/11/2017	OXTER SERVICES	CLEANING OF VARIOUS TOILETS FOR AUGUST 2017.	1		3,273.72
INV 18671	06/10/2017	OXTER SERVICES	KATRINE TOILETS. SUPPLY GLOVES, TOILET	1	90.29	
INV 18743	12/10/2017	OXTER SERVICES	ADMIN BUILDING. SUPPLY 1X BOX HAND TOWELL, 1 X BOX TOILET PAPER, 1 X CARTON OF BLACK 80L BIN BAGS, 1 X CARTON OF 27L WHITE BIN BAGS, 1 X ROLL CHUX.	1	929.99	
INV 18766	17/10/2017	OXTER SERVICES	NORTHAM DEPOT - SUPPLY 1 X CARTON TOILET	1	306.22	
INV 18650	22/09/2017	OXTER SERVICES	TOILET PAPER & HAND TOWEL FOR NORTHAM VISITOR CENTRE.	1	165.22	
INV 18514	25/08/2017	OXTER SERVICES	CLEANING OF VARIOUS TOILETS FOR AUGUST 2017.	1	1,782.00	
EFT28141	03/11/2017	PRESTIGE ALARMS	REPAIRS TO THE ADMINISTRATION	1		644.16
INV 0009465919/10/2017		PRESTIGE ALARMS	CENTRE ALARMS	1	644.16	
EFT28142	03/11/2017	PRIMARIES OF WA PTY LTD	REPAIRS TO THE ADMINISTRATION 50MM FILMAC BALL VALVE CENTRE ALARMS Repairs to the Administration Centre alarm system	1		42.41

Date: 01/12/2017
Time: 9:08:54AM

Shire of Northam

USER: Kathy Scholz
PAGE: 8

Cheque / EFT No	Date	Name	Invoice Description	Bank Code	INV Amount	Amount
INV 2520020028/08/2017		PRIMARIES OF WA PTY LTD	50MM FILMAC BALL VALVE	1	-42.41	
EFT28143	03/11/2017	REGIONAL PHYSIOTHERAPY & SPORTS INJURY CLINIC & IN BALANCE FITNESS	SENIOR SPORT FUNDING.	1		150.00
INV 0012841	01/11/2017	REGIONAL PHYSIOTHERAPY & SPORTS INJURY CLINIC & IN BALANCE FITNESS	SENIOR SPORT FUNDING.	1	150.00	
EFT28144	03/11/2017	RURAL PRESS REGIONAL MEDIA (WA) PTY LTD	MONTHLY NEWSLETTER FULL PAGE AD	1		1,191.61
INV 5246356	13/09/2017	RURAL PRESS REGIONAL MEDIA (WA) PTY LTD	PUBLIC NOTICE IN THE AVON VALLEY ADVOCATE 13/09/2017 FOR APPROVED LOCAL PLANNING SCHEME AMENDMENT NO. 5	1	194.04	
INV 5252198	27/09/2017	RURAL PRESS REGIONAL MEDIA (WA) PTY LTD	MONTHLY NEWSLETTER FULL PAGE AD	1	997.57	
EFT28145	03/11/2017	SKILL HIRE WA PTY LTD	LABOUR HIRE FOR NICHOLAS SHEER & ROBERT WILSON P/E 3/9/2017 & 10/09/2017.	1		20,259.87
INV AP50853	27/09/2017	SKILL HIRE WA PTY LTD	LABOUR HIRE TO NICHOLAS SCHEER & ROBERT WILSON W/E 24/9/2017.	1	3,874.92	
INV AP50687	22/08/2017	SKILL HIRE WA PTY LTD	LABOUR HIRE RUSSELL DEGRAY - W/E 20/08/2017.	1	1,472.63	
INV AP50812	20/09/2017	SKILL HIRE WA PTY LTD	LABOUR HIRE - NICHOLAS SCHEER & ROBERT WILSON W/E 17/9/2017.	1	4,980.03	
INV AP50775	13/09/2017	SKILL HIRE WA PTY LTD	LABOUR HIRE FOR NICHOLAS SHEER & ROBERT WILSON P/E 3/9/2017 & 10/09/2017.	1	6,894.51	
INV AP50893	04/10/2017	SKILL HIRE WA PTY LTD	LABOUR HIRE NICHOLAS SCHEER & ROBERT WILSON - 01/10/2017.	1	3,037.78	
EFT28146	03/11/2017	WHEATBELT SAFETYWEAR	PPE EQUIPMENT FOR PARKS & GARDENS.	1		202.00
INV 7710	11/09/2017	WHEATBELT SAFETYWEAR	PPE EQUIPMENT FOR PARKS & GARDENS.	1	202.00	
EFT28147	03/11/2017	WUNDOWIE SPRINGS PTY LTD WUNDOWIE ONE STOP	ASSORTED ITEMS FOR WUNDOWIE DEPOT.	1		122.80
INV 0000019729/07/2017		WUNDOWIE SPRINGS PTY LTD WUNDOWIE ONE STOP	ASSORTED ITEMS FOR WUNDOWIE DEPOT.	1	122.80	
EFT28148	07/11/2017	KLEENHEAT GAS	LPG GAS FOR BULK 4.30KL TANK FOR KILLARA ADULT DAY CARE CENTRE.	1		2,835.71
INV 2112434005/09/2017		KLEENHEAT GAS	LPG GAS FOR BULK 4.30KL TANK FOR KILLARA ADULT DAY CARE CENTRE.	1	2,835.71	

Date: 01/12/2017
Time: 9:08:54AM

Shire of Northam

USER: Kathy Scholz
PAGE: 9

Cheque / EFT No	Date	Name	Invoice Description	Bank Code	INV Amount	Amount
EFT28149	08/11/2017	ATTILA JOHN MENC SHELYI	COUNCIL PAYMENTS OCTOBER 2017.	1		553.28
INV OCTOBE31/10/2017		ATTILA JOHN MENC SHELYI	COUNCIL PAYMENTS OCTOBER 2017.	1	553.28	
EFT28150	08/11/2017	CARL PHILLIP DELLA	COUNCILOR PAYMENTS OCTOBER 2017.	1		553.28
INV OCTOBE31/10/2017		CARL PHILLIP DELLA	COUNCILOR PAYMENTS OCTOBER 2017.	1	553.28	
EFT28151	08/11/2017	CHRIS DAVIDSON	COUNCILLOR PAYMENTS OCTOBER 2017.	1		2,025.61
INV OCTOBE31/10/2017		CHRIS DAVIDSON	COUNCILLOR PAYMENTS OCTOBER 2017.		2,025.61	
EFT28152	08/11/2017	CHRISTOPHER RICHARD ANTONIO	COUNCILLOR PAYMENTS OCTOBER 2017.	1		3,339.18
INV OCTOBE31/10/2017		CHRISTOPHER RICHARD ANTONIO	COUNCILLOR PAYMENTS OCTOBER 2017.		3,339.18	
EFT28153	08/11/2017	DENIS GRAHAM BERESFORD	COUNCILLOR PAYMENTS OCTOBER 2017	1		1,352.45
INV OCTOBE31/10/2017		DENIS GRAHAM BERESFORD	COUNCILLOR PAYMENTS OCTOBER 2017		1,352.45	
EFT28154	08/11/2017	DESMOND ARNOLD HUGHES	COUNCILLOR PAYMENTS OCTOBER 2017.	1		1,352.45
INV OCTOBE31/10/2017		DESMOND ARNOLD HUGHES	COUNCILLOR PAYMENTS OCTOBER 2017.		1,352.45	
EFT28155	08/11/2017	JOHN PROUD	COUNCILLOR PAYMENTS OCTOBER 2017.	1		1,905.73
INV OCTOBE31/10/2017		JOHN PROUD	COUNCILLOR PAYMENTS OCTOBER 2017.		1,905.73	
EFT28156	08/11/2017	JULIE ELLEN GREENFIELD WILLIAMS	COUNCILLOR PAYMENTS OCTOBER 2017.	1		2,065.57
INV OCTOBE31/10/2017		JULIE ELLEN GREENFIELD WILLIAMS	COUNCILLOR PAYMENTS OCTOBER 2017.		2,065.57	
EFT28157	08/11/2017	MICHAEL PATRICK RYAN	CONCILOR PAYMENTS OCTOBER 2017.	1		825.47
INV OCTOBE31/10/2017		MICHAEL PATRICK RYAN	CONCILOR PAYMENTS OCTOBER 2017.	1	825.47	
EFT28158	08/11/2017	ROBERT WAYNE TINETTI	COUNCILLOR PAYMENTS OCTOBER 2017	1		1,905.73
INV OCTOBE31/10/2017		ROBERT WAYNE TINETTI	COUNCILLOR PAYMENTS OCTOBER 2017		1,905.73	
EFT28159	08/11/2017	STEVEN BRUCE POLLARD	COUNCILLOR PAYMENTS OCTOBER 2017.	1		4,794.70
INV OCTOBE31/10/2017		STEVEN BRUCE POLLARD	COUNCILLOR PAYMENTS OCTOBER 2017.		4,794.70	

Date: 01/12/2017
Time: 9:08:54AM

Shire of Northam

USER: Kathy Scholz
PAGE: 10

Cheque / EFT No	Date	Name	Invoice Description	Bank Code	INV Amount	Amount
EFT28160	08/11/2017	TERRY MATTHEW LITTLE	COUNCILLOR PAYMENTS OCTOBER 2017.	1		2,857.43
INV OCTOBE31/10/2017		TERRY MATTHEW LITTLE	COUNCILLOR PAYMENTS OCTOBER 2017.		2,857.43	
EFT28161	08/11/2017	ULO RUMJANTSEV	COUNCILLOR PAYMENTS OCTOBER 2017.	1		1,704.69
INV OCTOBE31/10/2017		ULO RUMJANTSEV	COUNCILLOR PAYMENTS OCTOBER 2017.		1,704.69	
EFT28162	10/11/2017	SPECIALISED TREE SERVICE	PRUNE NORTHAM TOWNSITE STREET TREES AS PER CONTRACT 19 OF 2015	1		10,003.50
INV 2657	06/11/2017	SPECIALISED TREE SERVICE	PRUNE NORTHAM TOWNSITE STREET TREES AS PER CONTRACT 19 OF 2015	1	10,003.50	
EFT28163	10/11/2017	ABBOTTS FORGE	REPAIR DRAIN GRATE ON CHIDLOW STREET	1		260.00
INV 0000274513/09/2017		ABBOTTS FORGE	REPAIR DRAIN GRATE ON CHIDLOW STREET	1	260.00	
EFT28164	10/11/2017	ANDY'S PLUMBING SERVICE	BERNARD PARK TOILETS. SERVICE ALL AUTO SHUT OFF TAPS IN BASINS. MALE AND FEMALE. ONE LEAKING OTHERS TURNING OFF TOO QUICKLY OR TOO LONG.	1		2,325.95
INV A17765	27/10/2017	ANDY'S PLUMBING SERVICE	BERNARD PARK TOILETS. SERVICE ALL AUTO SHUT OFF TAPS IN BASINS. MALE AND FEMALE. ONE LEAKING OTHERS TURNING OFF TOO QUICKLY OR TOO LONG.	1	1,190.75	
INV A17771	30/10/2017	ANDY'S PLUMBING SERVICE	APEX TOILETS. EMERGENCY REPAIRS TO TOILETS.	1	396.00	
INV A17770	27/10/2017	ANDY'S PLUMBING SERVICE	BERNARD PARK TOILETS. EMERGENCY REPAIRS TO TOILETS.	1	253.00	
INV A17772	30/10/2017	ANDY'S PLUMBING SERVICE	KATRINE TOILETS. REPAIR LEAKING TAP. CALLED IN BY PUBLIC.	1	486.20	
EFT28165	10/11/2017	APPLIED INDUSTRIAL TECHNOLOGIES T/A NORTHAM BEARINGS	CLAMPS FOR WATER TANK ON PN1611	1		14.43
INV 6005788	11/10/2017	APPLIED INDUSTRIAL TECHNOLOGIES T/A NORTHAM BEARINGS	CLAMPS FOR WATER TANK ON PN1611	1	14.43	
EFT28166	10/11/2017	AUSTRAL MERCANTILE COLLECTIONS PTY LTD	REIMBURSABLE LEGAL CHARGES - PERIOD ENDING 29/10/2017.	1		8,207.23
INV 72801	29/10/2017	AUSTRAL MERCANTILE COLLECTIONS PTY LTD	REIMBURSABLE LEGAL CHARGES - PERIOD ENDING 29/10/2017.	1	8,207.23	
EFT28167	10/11/2017	AVON DEMOLITION & EARTHMOVING	MANAGEMENT OF INKPEN ROAD WASTE MANAGEMENT FACILITY. FROM 24/10/2017 TO 05/11/2017.	1		1,568.00

Date: 01/12/2017
Time: 9:08:54AM

Shire of Northam

USER: Kathy Scholz
PAGE: 11

Cheque / EFT No	Date	Name	Invoice Description	Bank Code	INV Amount	Amount
INV 0066	05/11/2017	AVON DEMOLITION & EARTHMOVING	MANAGEMENT OF INKPEN ROAD WASTE MANAGEMENT FACILITY. FROM 24/10/2017 TO 05/11/2017.	1	1,568.00	
EFT28168	10/11/2017	AVON MIDLAND COUNTRY ZONE OF WA LOCAL GOVERNMENT ASSOCIATION	MEMBERSHIP SUBSCRIPTION 2017/18	1		2,200.00
INV 0000030101/10/2017	10/10/2017	AVON MIDLAND COUNTRY ZONE OF WA LOCAL GOVERNMENT ASSOCIATION	MEMBERSHIP SUBSCRIPTION 2017/18	1	2,200.00	
EFT28169	10/11/2017	AVON TELECOMS PTY LTD	WUNDOWIE LIBRARY. INSTALL 2 X NEW SECURITY CAMERAS AFTER POWER SURGE.	1		1,301.00
INV 0000466727/10/2017	10/10/2017	AVON TELECOMS PTY LTD	WUNDOWIE LIBRARY. INSTALL 2 X NEW SECURITY CAMERAS AFTER POWER SURGE.	1	660.00	
INV 0000466201/11/2017	11/10/2017	AVON TELECOMS PTY LTD	SECURITY MONITORING FOR NOVEMBER 2017 AT VARIOUS SHIRE BUILDINGS.	1	641.00	
EFT28170	10/11/2017	BOYD KICKETT	WORKSHOP/MEETING FEE - TO IDENTIFY A NUMBER OF SPECIMEN FOR THE AEIC DISPLAY 17/10/2017.	1		50.00
INV JW201020/10/2017	10/10/2017	BOYD KICKETT	WORKSHOP/MEETING FEE - TO IDENTIFY A NUMBER OF SPECIMEN FOR THE AEIC DISPLAY 17/10/2017.	1	50.00	
EFT28171	10/11/2017	CHAS CLARKSON	ADDITION OF GLOBE LIGHTS TO EXISTING SYSTEM- CHRISTMAS 2017 (AS PER QUOTE)	1		11,328.90
INV INV234031/10/2017	10/10/2017	CHAS CLARKSON	ADDITION OF GLOBE LIGHTS TO EXISTING SYSTEM- CHRISTMAS 2017 (AS PER QUOTE)	1	11,328.90	
EFT28172	10/11/2017	CHIDLOW BASKETBALL CLUB	KIDSPORT FUNDING	1		85.00
INV KS0146807/11/2017	11/10/2017	CHIDLOW BASKETBALL CLUB	KIDSPORT FUNDING	1	85.00	
EFT28173	10/11/2017	CHRISTOPHER GLENN GOFF	JUBILEE PAVILLION. DEMOLISH AND DISPOSE OF STEEL SHADE STRUCTURE AT FRONT OF JUBILEE PAVILION.	1		6,600.00
INV 2017-7-1107/11/2017	11/10/2017	CHRISTOPHER GLENN GOFF	JUBILEE PAVILLION. DEMOLISH AND DISPOSE OF STEEL SHADE STRUCTURE AT FRONT OF JUBILEE PAVILION.	1	6,600.00	
EFT28174	10/11/2017	COLIN DUNCAN GRANT	CLEANING WUNDOWIE HALL, WUNDOWIE LIBRARY, WUNDOWIE DEPOT - OCTOBER 2017.	1		1,898.00
INV P883	31/10/2017	COLIN DUNCAN GRANT	CLEANING WUNDOWIE HALL, WUNDOWIE LIBRARY, WUNDOWIE DEPOT - OCTOBER 2017.	1	1,898.00	
EFT28175	10/11/2017	COUNTRY COPIERS NORTHAM	STATIONERY FOR NORTHAM SWIMMING POOL	1		243.05
INV 41063	31/10/2017	COUNTRY COPIERS NORTHAM	DIARY FOR NORTHAM AND WUNDOWIE SWIMMING POOLS	1	42.70	

Date: 01/12/2017
Time: 9:08:54AM

Shire of Northam

USER: Kathy Scholz
PAGE: 12

Cheque / EFT No	Date	Name	Invoice Description	Bank Code	INV Amount	Amount
INV 41063	31/10/2017	COUNTRY COPIERS NORTHAM	STATIONERY FOR NORTHAM SWIMMING POOL	1	119.70	
INV 41063	31/10/2017	COUNTRY COPIERS NORTHAM	STATIONERY FOR WUNDOWIE POOL	1	80.65	
EFT28176	10/11/2017	COURIER AUSTRALIA	FREIGHT CHARGES FOR LIBRARY, VISITORS CENTRE, CESM, HEALTH & DEPOT.	1		285.46
INV 0322	22/09/2017	COURIER AUSTRALIA	FREIGHT CHARGES FOR LIBRARY, VISITORS CENTRE, CESM, HEALTH & DEPOT.	1	285.46	
EFT28177	10/11/2017	DEBBIE HUGHES - PERTH FACE PAINTING COMPANY	2HR STAGE PERFORMANCE FOR 2017 SENIORS WEEK GALA CONCERT	1		800.00
INV VW0311203/11/2017		DEBBIE HUGHES - PERTH FACE PAINTING COMPANY	2HR STAGE PERFORMANCE FOR 2017 SENIORS WEEK GALA CONCERT	1	800.00	
EFT28178	10/11/2017	DMC CLEANING	CLEANING SERVICES FOR OCTOBER 2017 AS PER RFT 3 OF 2017.	1		5,096.12
INV SON001	27/10/2017	DMC CLEANING	CLEANING SERVICES FOR OCTOBER 2017 AS PER RFT 3 OF 2017.	1	5,096.12	
EFT28179	10/11/2017	EL CABALLO SOCIAL GOLF CLUB INC	SENIOR SPORT FUNDING	1		150.00
INV 0000023028/10/2017		EL CABALLO SOCIAL GOLF CLUB INC	SENIOR SPORT FUNDING	1	150.00	
EFT28180	10/11/2017	EMMA O'DRISCOLL	REIMBURSEMENT FOR POLICE CLEARANCE APPLICATION.	1		52.60
INV 2230652	01/11/2017	EMMA O'DRISCOLL	REIMBURSEMENT FOR POLICE CLEARANCE APPLICATION.	1	52.60	
EFT28181	10/11/2017	ENVIRONMENTAL HEALTH AUSTRALIA	WA CONFERENCE 2017 1 DAY REGISTRATION FOR CARMEN SADLIER.	1		350.00
INV 2898	23/08/2017	ENVIRONMENTAL HEALTH AUSTRALIA	WA CONFERENCE 2017 1 DAY REGISTRATION FOR CARMEN SADLIER.	1	350.00	
EFT28182	10/11/2017	ERIC DENNIS COLBUNG	REIMBURSEMENT FOR POLICE CLEARANCE APPLICATION.	1		52.60
INV 2230638	08/11/2017	ERIC DENNIS COLBUNG	REIMBURSEMENT FOR POLICE CLEARANCE APPLICATION.	1	52.60	
EFT28183	10/11/2017	GLENN STUART BEVERIDGE	APEX PARK TOILETS. REPLACE 2 X DAMAGED DOORS AND LOCKS AND REPLACE BROKEN TOILET SEAT COVERS DUE TO VANDALISM.	1		5,065.90

Date: 01/12/2017
Time: 9:08:54AM

Shire of Northam

USER: Kathy Scholz
PAGE: 13

Cheque / EFT No	Date	Name	Invoice Description	Bank Code	INV Amount	Amount
INV 536	07/11/2017	GLENN STUART BEVERIDGE	APEX PARK TOILETS. REPLACE 2 X DAMAGED DOORS AND LOCKS AND REPLACE BROKEN TOILET SEAT COVERS DUE TO VANDALISM.	1	1,232.00	
INV 528	06/11/2017	GLENN STUART BEVERIDGE	BERNARD PARK TOILETS. REPLACE GLOBE IN PARENTS TOILET.	1	165.00	
INV 35	06/11/2017	GLENN STUART BEVERIDGE	SUSPENSION BRIDGE. REPLACE 2 X BOARDS DUE TO VANDALISM.	1	275.00	
INV 532	06/11/2017	GLENN STUART BEVERIDGE	VISITORS CENTRE - SUPPLY & INSTALL DECKING TO FRONT RAMP	1	990.00	
INV 534	06/11/2017	GLENN STUART BEVERIDGE	RELOCATE BLACK POOL FENCING ON OUTSIDE COURTS	1	759.00	
INV 526	26/10/2017	GLENN STUART BEVERIDGE	REPAIRS TO HOLE IN FENCE ON OUTSIDE COURTS	1	99.00	
INV 33	06/11/2017	GLENN STUART BEVERIDGE	NORTHAM POOL INSTALL EMERGENCY EXIT SIGNS	1	132.00	
INV 527	26/10/2017	GLENN STUART BEVERIDGE	REPAIR OF BASKETBALL RING ON COURT 7.	1	150.00	
INV 530	06/11/2017	GLENN STUART BEVERIDGE	WUNDOWIE POOL - CONCRETE STEELE BRACKETS TO ANCHOR	1	933.90	
INV 531	06/11/2017	GLENN STUART BEVERIDGE	FLUFFY DUCKLINGS. REPLACE LOCK TO SECURITY SCREEN.	1	264.00	
INV 529	06/11/2017	GLENN STUART BEVERIDGE	REPAIR TO HOLE UNDER DOWN PIPE	1	66.00	
EFT28184	10/11/2017	GROVE WESLEY DESIGN ART	STOCK PURCHASES FOR VISITORS CENTRE.	1		242.00
INV 4595	07/07/2017	GROVE WESLEY DESIGN ART	STOCK PURCHASES FOR VISITORS CENTRE.	1	242.00	
EFT28185	10/11/2017	HOST AUTO REPAIRS	REPAIRS TO N2014/STH BK 1.4 - LIGHT TANKER BUSH FIRE ANNUAL SERVICE.	1		744.00
INV 60888	26/09/2017	HOST AUTO REPAIRS	CLACKLINE 1.4 - ADJUST NEW PLATFORM DOOR KNOB TO OPERATE CORRECTLY	1	54.45	
INV 61018	15/10/2017	HOST AUTO REPAIRS	IRISHTOWN 2.4 - REPAIR FUEL LEAK ON AXILLURY PUMP	1	124.10	
INV 61023	20/10/2017	HOST AUTO REPAIRS	REPAIRS TO MIRROR ASSEMBLY ON ICIG323/C/LINE 2.4.	1	176.05	
INV 61061	30/10/2017	HOST AUTO REPAIRS	REPAIRS TO N2014/STH BK 1.4 - LIGHT TANKER BUSH FIRE ANNUAL SERVICE.	1	389.40	
EFT28186	10/11/2017	JEAN MCGREADY	REFUND OF REGISTRATION FEES DUE TO REDUCTION OF FEES AS STERILIZATION CERTIFICATE HAS BEEN PROVIDED.	1		150.00

Date: 01/12/2017
Time: 9:08:54AM

Shire of Northam

USER: Kathy Scholz
PAGE: 14

Cheque / EFT No	Date	Name	Invoice Description	Bank Code	INV Amount	Amount
INV KW0311203/11/2017		JEAN MCGREADY	REFUND OF REGISTRATION FEES DUE TO REDUCTION OF FEES AS STERILIZATION CERTIFICATE HAS BEEN PROVIDED.	1	150.00	
EFT28187	10/11/2017	KATHY DAVIS	WORKSHOP/MEETING FEE - TO IDENTIFY A NUMBER OF SPECIMEN FOR THE AEIC DISPLAY 17/10/2017.	1		50.00
INV JW201020/10/2017		KATHY DAVIS	WORKSHOP/MEETING FEE - TO IDENTIFY A NUMBER OF SPECIMEN FOR THE AEIC DISPLAY 17/10/2017.	1	50.00	
EFT28188	10/11/2017	KERBTECH P/L T/A GDR CIVIL CONTRACTING	CRUSHED LIMESTONE 75MM FOR ROAD MAINTENANCE.	1		849.92
INV 001236	09/10/2017	KERBTECH P/L T/A GDR CIVIL CONTRACTING	CRUSHED LIMESTONE 75MM FOR ROAD MAINTENANCE.	1	849.92	
EFT28189	10/11/2017	KIM COLBOURNE	RASPBERRY PI FOR CATALOGUE COMPUTER & 5 WIFI DONGLES FOR PUBLIC ACCESS COMPUTERS.	1		206.93
INV RR211020/10/2017		KIM COLBOURNE	GARDEN ARCH TO FORM GATEWAY INTO CHILDRENS AREA.	1	85.00	
INV RR0610206/10/2017		KIM COLBOURNE	RASPBERRY PI FOR CATALOGUE COMPUTER & 5 WIFI DONGLES FOR PUBLIC ACCESS COMPUTERS.	1	121.93	
EFT28190	10/11/2017	KIMBERLEY MICHAEL JOHNSON	REIMBURSEMENT FOR POLICE CLEARANCE APPLICATION.	1		52.60
INV 586671	16/10/2017	KIMBERLEY MICHAEL JOHNSON	REIMBURSEMENT FOR POLICE CLEARANCE APPLICATION.	1	52.60	
EFT28191	10/11/2017	KOORI KIDS PTY LIMITED	ANNUAL CONTRIBUTION TO NAIDOC INITIATIVES 2017, TOWARDS DESIGN PRINTING AND DISTRIBUTION OF INFORMATION PACKS, ENTRY FORMS TO ALL SCHOOLS ACROSS THE STATE.	1		450.00
INV N177/20109/11/2017		KOORI KIDS PTY LIMITED	ANNUAL CONTRIBUTION TO NAIDOC INITIATIVES 2017, TOWARDS DESIGN PRINTING AND DISTRIBUTION OF INFORMATION PACKS, ENTRY FORMS TO ALL SCHOOLS ACROSS THE STATE.	1	450.00	
EFT28192	10/11/2017	LGIS - LOCAL GOVERNMENT INSURANCE SERVICES	2016-2017 MOTOR VEHICLE PREMIUM ADJUSTMENT ADDITIONAL PREMIUM AS AT JUNE 2017.	1		4,212.37
INV 062-197231/10/2017		LGIS - LOCAL GOVERNMENT INSURANCE SERVICES	2016-2017 MOTOR VEHICLE PREMIUM ADJUSTMENT ADDITIONAL PREMIUM AS AT JUNE 2017.	1	4,212.37	
EFT28193	10/11/2017	LGIS WA	WAGES ADJUSTMENT TO WORKCARE YEAR ENDED 30/06/2017.	1		15,536.79

Date: 01/12/2017
Time: 9:08:54AM

Shire of Northam

USER: Kathy Scholz
PAGE: 15

Cheque / EFT No	Date	Name	Invoice Description	Bank Code	INV Amount	Amount
INV 100-130202/11/2017		LGIS WA	WAGES ADJUSTMENT TO WORKCARE YEAR ENDED 30/06/2017.	1	15,536.79	
EFT28194	10/11/2017	MALINOWSKI HOLDINGS PTY LTD	RENT - 174 FITZGERALD STREET, NORTHAM - NOVEMBER 2017.	1		916.66
INV 02566	29/10/2017	MALINOWSKI HOLDINGS PTY LTD	RENT - 174 FITZGERALD STREET, NORTHAM - NOVEMBER 2017.	1	916.66	
EFT28195	10/11/2017	MAYBERRY HAMMOND & CO	DRAWING UP THE LEASE FOR CLACKLINE HALL, CLACKLINE PROGRESS ASSOCIATION	1		924.00
INV 40935	06/11/2017	MAYBERRY HAMMOND & CO	DRAWING UP THE LEASE FOR CLACKLINE HALL, CLACKLINE PROGRESS ASSOCIATION	1	462.00	
INV 40936	06/11/2017	MAYBERRY HAMMOND & CO	DRAWING UP THE LEASE FOR BAKERS HILL PROGRESS ASSOC. FOR BAKERS HILL PAVILLION 17 BERRY BROW ROAD	1	462.00	
EFT28196	10/11/2017	MOORE STEPHENS (WA) PTY LTD	FINAL BILLING IN RESPECT OF THE AUDIT FOR THE YEAR ENDED 30TH JUNE 2017 IN ACCORDANCE WITH OUR AGREEMENT.	1		11,610.50
INV 304562	31/10/2017	MOORE STEPHENS (WA) PTY LTD	FINAL BILLING IN RESPECT OF THE AUDIT FOR THE YEAR ENDED 30TH JUNE 2017 IN ACCORDANCE WITH OUR AGREEMENT.	1	11,610.50	
EFT28197	10/11/2017	MR FESTOON LIGHTS	HEAVY DUTY LOW VOLTAGE FESTOON KIT (240M - 2 X TRANSFORMER, 2 X 2M TAIL INCLUDED)	1		3,995.00
INV 63283	21/07/2017	MR FESTOON LIGHTS	HEAVY DUTY LOW VOLTAGE FESTOON KIT (240M - 2 X TRANSFORMER, 2 X 2M TAIL INCLUDED)	1	3,995.00	
EFT28198	10/11/2017	NETSIGHT	MYOSH MONTHLY SUBSCRIPTION - NOVEMBER 2017.	1		671.00
INV INV-218601/11/2017		NETSIGHT	MYOSH MONTHLY SUBSCRIPTION - NOVEMBER 2017.	1	671.00	
EFT28199	10/11/2017	NORTHAM AMATEUR BASKETBALL ASSOCIATION	KIDSPORT FUNDING FOR J BROOM, L COLLINS, A DAVIS, A DIMMER, T JONES, J KICKETT, T LAWSON, H NARRIER, Q PICKETT, K RYDER, R SHAW, S SHAW, S TODD, D UGLE, S YATES	1		1,250.00
INV KS0148267/11/2017		NORTHAM AMATEUR BASKETBALL ASSOCIATION	KIDSPORT FUNDING FOR J BROOM, L COLLINS, A DAVIS, A DIMMER, T JONES, J KICKETT, T LAWSON, H NARRIER, Q PICKETT, K RYDER, R SHAW, S SHAW, S TODD, D UGLE, S YATES	1	1,250.00	
EFT28200	10/11/2017	NORTHAM AND DISTRICTS GUN CLUB	SENIOR SPORT FUNDING.	1		450.00

Date: 01/12/2017
Time: 9:08:54AM

Shire of Northam

USER: Kathy Scholz
PAGE: 16

Cheque / EFT No	Date	Name	Invoice Description	Bank Code	INV Amount	Amount
INV 0033	06/11/2017	NORTHAM AND DISTRICTS GUN CLUB	SENIOR SPORT FUNDING.	1	450.00	
EFT28201	10/11/2017	NORTHAM BETTA HOME LIVING	BAGLESS VAX VACUUM CLEANER FOR NORTHAM POOL.	1		149.00
INV 2957 L55601	11/11/2017	NORTHAM BETTA HOME LIVING	BAGLESS VAX VACUUM CLEANER FOR NORTHAM POOL.	1	149.00	
EFT28202	10/11/2017	NORTHAM COUNTRY CLUB INC	SENIOR SPORT FUNDING FOR ROGER	1		450.00
INV 1909	26/10/2017	NORTHAM COUNTRY CLUB INC	SENIOR SPORT FUNDING FOR ROGER	1	150.00	
INV 1910	27/10/2017	NORTHAM COUNTRY CLUB INC	SENIOR SPORT FUNDING	1	150.00	
INV 1920	03/11/2017	NORTHAM COUNTRY CLUB INC	SENIOR SPORT FUNDING	1	150.00	
EFT28203	10/11/2017	NORTHAM FAMILY PRACTICE	PRE-EMPLOYMENT MEDICAL FOR SAM NEALE	1		236.50
INV 65100	12/10/2017	NORTHAM FAMILY PRACTICE	PRE-EMPLOYMENT MEDICAL FOR SAM NEALE	1	236.50	
EFT28204	10/11/2017	NORTHAM INDOOR HOCKEY ASSOCIATION	KIDSPORT FUNDING FOR JORDON HUBON & CARLO GIORAI.	1		100.00
INV KS003	07/11/2017	NORTHAM INDOOR HOCKEY ASSOCIATION	KIDSPORT FUNDING FOR JORDON HUBON & CARLO GIORAI.	1	100.00	
EFT28205	10/11/2017	NORTHAM MITRE 10 SOLUTIONS	PAINT FOR FOOTBALL MARKING	1		23.43
INV 1021829715	09/2017	NORTHAM MITRE 10 SOLUTIONS	PAINT FOR FOOTBALL MARKING	1	23.43	
EFT28206	10/11/2017	NORTHAM NURSERY	TABLE CENTRE PIECES AND MATURE TREES FOR ROOM DECORATION AT 2017 SENIORS GALA CONCERT 03/11/2017	1		200.00
INV 78	03/11/2017	NORTHAM NURSERY	TABLE CENTRE PIECES AND MATURE TREES FOR ROOM DECORATION AT 2017 SENIORS GALA CONCERT 03/11/2017	1	200.00	
EFT28207	10/11/2017	NORTHAM SENIOR CITIZENS SOCIAL CLUB INC	SENIOR SPORT FUNDING	1		150.00
INV 206	06/10/2017	NORTHAM SENIOR CITIZENS SOCIAL CLUB INC	SENIOR SPORT FUNDING	1	150.00	
EFT28208	10/11/2017	NORTHAM VETERINARY CENTRE	EUTHANASIA OF A CAT	1		82.00
INV 61541	10/10/2017	NORTHAM VETERINARY CENTRE	EUTHANASIA OF A CAT	1	82.00	

Date: 01/12/2017
Time: 9:08:54AM

Shire of Northam

USER: Kathy Scholz
PAGE: 17

Cheque / EFT No	Date	Name	Invoice Description	Bank Code	INV Amount	Amount
EFT28209	10/11/2017	OXTER SERVICES	VISITORS CENTRE. SUPPLY 3 CARTONS OF TOILET PAPER AND 3 CARTONS OF HAND TOWELL.	1		1,249.28
INV 18797	24/10/2017	OXTER SERVICES	BERNARD PARK TOILETS. SUPPLY 3 X TOILET PAPER. SHIRE ADMIN TOILET PAPER & MEMORIAL HALL TOILET PAPER.	1	399.85	
INV 18838	01/11/2017	OXTER SERVICES	VISITORS CENTRE. SUPPLY 3 CARTONS OF TOILET PAPER AND 3 CARTONS OF HAND TOWELL.	1	849.43	
EFT28210	10/11/2017	PERFECT COMPUTER SOLUTIONS PTY LTD	23/10/2017 - CONFIGURE EDGEROUTER AND TPLINK MODEM FOR DEPOT. DO INITIAL CONFIG. COME UP WITH CONFIG TO MAKE THE SITE TO SITE VPN'S WORK.	1		297.50
INV 23015	31/10/2017	PERFECT COMPUTER SOLUTIONS PTY LTD	MONTHLY FEE FOR DAILY MONITORING, FOR OCTOBER 2017.	1	85.00	
INV 23038	02/11/2017	PERFECT COMPUTER SOLUTIONS PTY LTD	23/10/2017 - CONFIGURE EDGEROUTER AND TPLINK MODEM FOR DEPOT. DO INITIAL CONFIG. COME UP WITH CONFIG TO MAKE THE SITE TO SITE VPN'S WORK.	1	212.50	
EFT28211	10/11/2017	PERTH AMUSEMENT & EVENT HIRE	1 X COMBO CASTLE, 1 X ARMY OBSTACLE WITH OPERATORS FOR 2017 DOG'S DAY OUT. SATURDAY 21ST OCTOBER FROM 0900-1300, BERNARD PARK NORTHAM	1		980.00
INV C0127	23/10/2017	PERTH AMUSEMENT & EVENT HIRE	1 X COMBO CASTLE, 1 X ARMY OBSTACLE WITH OPERATORS FOR 2017 DOG'S DAY OUT. SATURDAY 21ST OCTOBER FROM 0900-1300, BERNARD PARK NORTHAM	1	980.00	
EFT28212	10/11/2017	PROFESSIONAL LOCKSERVICE	WUNDOWIE HALL. SUPPLY 2 X KEY BAA-C05A.	1		153.45
INV 0010209901/11/2017		PROFESSIONAL LOCKSERVICE	WUNDOWIE HALL. SUPPLY 2 X KEY BAA-C05A.	1	153.45	
EFT28213	10/11/2017	PUBLIC TRANSPORT AUTHORITY	TRAIN TICKET SALES FOR OCTOBER 2017.	1		78.64
INV OCTOBE01/11/2017		PUBLIC TRANSPORT AUTHORITY	TRAIN TICKET SALES FOR OCTOBER 2017.	1	78.64	
EFT28214	10/11/2017	RED DOT STORES	3 TIERED SHELF FOR LIBRARY.	1		25.00
INV 3284581426/10/2017		RED DOT STORES	3 TIERED SHELF FOR LIBRARY.	1	25.00	
EFT28215	10/11/2017	SGS AUSTRALIA PTY LTD	OLD QUARRY RD TIP BORE MONITORING SEPTEMBER 2017.	1		1,172.60
INV NE0006610/10/2017		SGS AUSTRALIA PTY LTD	OLD QUARRY RD TIP BORE MONITORING SEPTEMBER 2017.	1	1,172.60	

Date: 01/12/2017
Time: 9:08:54AM

Shire of Northam

USER: Kathy Scholz
PAGE: 18

Cheque / EFT No	Date	Name	Invoice Description	Bank Code	INV Amount	Amount
EFT28216	10/11/2017	THE WORKWEAR GROUP	UNIFORMS FOR LAURA WALSH.	1		394.40
INV 0281150325/10/2017		THE WORKWEAR GROUP	UNIFORMS FOR LAURA WALSH.	1	344.25	
INV 0300717601/11/2017		THE WORKWEAR GROUP	UNIFORM FOR LAURA WALSH.	1	50.15	
EFT28217	10/11/2017	TRISSET BOSS BUSINESS FORMS PTY LTD	7500X RATES INSTALMENT NOTICES 3 BOXES	1		1,452.00
INV 12044	26/10/2017	TRISSET BOSS BUSINESS FORMS PTY LTD	7500X RATES INSTALMENT NOTICES 3 BOXES	1	1,452.00	
EFT28218	10/11/2017	TYRECYCLE PTY LTD	RECYCLING OF TYRES AT OLD QUARRY.	1		3,658.01
INV 654212	06/10/2017	TYRECYCLE PTY LTD	RECYCLING OF TYRES AT OLD QUARRY.	1	3,658.01	
EFT28219	10/11/2017	VISIT MERCHANDISE	STOCK PURCHASES FOR VISITORS CENTRE.	1		424.28
INV 139109	01/11/2017	VISIT MERCHANDISE	STOCK PURCHASES FOR VISITORS CENTRE.	1	424.28	
EFT28220	10/11/2017	WA CONTRACT RANGER SERVICES	CAT MANGEMENT EXPENSE OCTOBER 2017.	1		660.00
INV 01224	02/11/2017	WA CONTRACT RANGER SERVICES	CAT MANGEMENT EXPENSE OCTOBER 2017.	1	660.00	
EFT28221	10/11/2017	WHEATBELT PARTY AND EVENT HIRE	TABLE CLOTH HIRE FOR 2017 SENIORS GALA CONCERT	1		480.00
INV 1011	02/11/2017	WHEATBELT PARTY AND EVENT HIRE	TABLE CLOTH HIRE FOR 2017 SENIORS GALA CONCERT	1	480.00	
EFT28222	10/11/2017	WHEATBELT SAFETYWEAR	PROTECTIVE CLOTHING FOR DEPOT STAFF.	1		792.00
INV 7769	05/10/2017	WHEATBELT SAFETYWEAR	BOOTS ALLOWANCE FOR HAROLD GODDARD	1	150.00	
INV 7795	19/10/2017	WHEATBELT SAFETYWEAR	BOOTS ALLOWANCE FOR COLIN LEWIS	1	150.00	
INV 7779	11/10/2017	WHEATBELT SAFETYWEAR	SMALL RIGGERS GLOVES	1	48.00	
INV 7816	30/10/2017	WHEATBELT SAFETYWEAR	PROTECTIVE CLOTHING FOR DEPOT STAFF.	1	444.00	
EFT28223	10/11/2017	WUNDOWIE AND DISTRICT'S MENS SHED INC	REPAIRS TO 4 WOODEN PICNIC BENCHES	1		800.00
INV 0102	30/10/2017	WUNDOWIE AND DISTRICT'S MENS SHED INC	REPAIRS TO 4 WOODEN PICNIC BENCHES	1	800.00	
EFT28224	10/11/2017	YOMBICH DESIGN	30% OF BALLADONG PAINTING COMMISSION	1		690.00
INV 800012	07/11/2017	YOMBICH DESIGN	30% OF BALLADONG PAINTING COMMISSION	1	690.00	

Date: 01/12/2017
Time: 9:08:54AM

Shire of Northam

USER: Kathy Scholz
PAGE: 19

Cheque / EFT No	Date	Name	Invoice Description	Bank Code	INV Amount	Amount
EFT28225	10/11/2017	YORK & DISTRICT COMMUNITY MATTERS	1/4 ADVERT IN AUGUST EDITION OF COMMUNITY MATTERS FOR 2017 BALLOON FIESTA	1		356.00
INV 0001012029/07/2017		YORK & DISTRICT COMMUNITY MATTERS	1/4 ADVERT IN AUGUST EDITION OF COMMUNITY MATTERS FOR 2017 BALLOON FIESTA	1	356.00	
EFT28226	13/11/2017	AVON VALLEY CONTRACTORS	GRADER DRY HIRE FOR THE PERIOD 01/10/17 TO 31/10/17 WHILST SHIRE GRADER UNDER REPAIRS.	1		11,000.00
INV 2032	01/11/2017	AVON VALLEY CONTRACTORS	GRADER DRY HIRE FOR THE PERIOD 01/10/17 TO 31/10/17 WHILST SHIRE GRADER UNDER REPAIRS.	1	11,000.00	
EFT28227	13/11/2017	COUNTRYWIDE POOLS	20 X 10KG PUREX POOL CHLORINE, 10 X 15LT PUREX LIQUID CHLORINE & 5 X 25KG PUREX STABILISER FOR NORTHAM POOL.	1		2,424.67
INV 24051	11/10/2017	COUNTRYWIDE POOLS	REPAIR CHAINSAW MS311 (EXHAUST)	1	52.50	
INV 24038	11/10/2017	COUNTRYWIDE POOLS	20 X 10KG PUREX POOL CHLORINE, 10 X 15LT PUREX LIQUID CHLORINE & 5 X 25KG PUREX STABILISER FOR NORTHAM POOL.	1	1,972.74	
INV 24225	31/10/2017	COUNTRYWIDE POOLS	REPAIR STIHL BRUSHCUTTER, SHINDAWA BRUSHCUTTER & HUSQVARNA CHAINSAW.	1	399.43	
EFT28228	13/11/2017	FRAMESWEST	REWELD STAINLESS STEEL WHEELCHAIR RAMP BACK ON AT BERNARD PARK.	1		539.00
INV 0001401430/10/2017		FRAMESWEST	REWELD STAINLESS STEEL WHEELCHAIR RAMP BACK ON AT BERNARD PARK.	1	539.00	
EFT28229	13/11/2017	KERBTECH P/L T/A GDR CIVIL CONTRACTING	GRADING FIREBREAKS AT TROTTING TRACK AND ROAD TRAIN ASSEMBLY AREA PRIOR TO BURN	1		1,496.00
INV 1238	11/10/2017	KERBTECH P/L T/A GDR CIVIL CONTRACTING	GRADING FIREBREAKS AT TROTTING TRACK AND ROAD TRAIN ASSEMBLY AREA PRIOR TO BURN	1	1,001.00	
INV 1240	17/10/2017	KERBTECH P/L T/A GDR CIVIL CONTRACTING	HIRE OF FLOAT TO TRANSPORT TYRE ROLLER FROM TRIMMER ROAD TO CHRISTMASS ROAD	1	495.00	
EFT28230	13/11/2017	KLEENWEST DISTRIBUTORS	240LT BIN LINERS & BLUE STRETCH VINYL FOR NORTHAM REC CENTRE.	1		119.90
INV 0002725710/10/2017		KLEENWEST DISTRIBUTORS	240LT BIN LINERS & BLUE STRETCH VINYL FOR NORTHAM REC CENTRE.	1	119.90	
EFT28231	13/11/2017	LANDGATE	GROSS RENTAL VALUATIONS CHARGEABLE SCHEDULE NO:G2017/9 DATED 29/07/2017 TO 25/08/2017.	1		583.54
INV 334076-1Q28/09/2017		LANDGATE	GROSS RENTAL VALUATIONS CHARGEABLE SCHEDULE NO:G2017/9 DATED 29/07/2017 TO 25/08/2017.	1	583.54	

Date: 01/12/2017
Time: 9:08:54AM

Shire of Northam

USER: Kathy Scholz
PAGE: 20

Cheque / EFT No	Date	Name	Invoice Description	Bank Code	INV Amount	Amount
EFT28232	13/11/2017	LLOYDS EARTHMOVING	3T CONCRETE MIX FOR FOOTPATH	1		132.40
INV INV-023112/10/2017		LLOYDS EARTHMOVING	3T CONCRETE MIX FOR FOOTPATH	1	119.90	
INV INV-024520/10/2017		LLOYDS EARTHMOVING	1 X NATIVE PLANT FOR CITIZENSHIP CEREMONY ON 20/10/2017.	1	12.50	
EFT28233	13/11/2017	MICRO PRODUCTS AUSTRALIA	REACHARABLE BLUETOOTH READER/WRITER FOR RANGERS.	1		889.50
INV 0000543901/11/2017		MICRO PRODUCTS AUSTRALIA	REACHARABLE BLUETOOTH READER/WRITER FOR RANGERS.	1	889.50	
EFT28234	13/11/2017	NAVMAN WIRELESS PTY LTD	MONTHLY SUBSCRIPTION SERVICE FEE FLEET TRACKING SYSTEM 15/10/2017 TO 14/11/2017.	1		1,264.29
INV 9108125505/10/2017		NAVMAN WIRELESS PTY LTD	MONTHLY SATELLITE SERVICE FEE FLEET TRACKING SYSTEM	1	417.67	
INV 9108634415/10/2017		NAVMAN WIRELESS PTY LTD	MONTHLY SUBSCRIPTION SERVICE FEE FLEET TRACKING SYSTEM 15/10/2017 TO 14/11/2017.	1	846.62	
EFT28235	13/11/2017	NORTHAM FEED & HIRE	DOG FOOD	1		77.00
INV 0000091131/10/2017		NORTHAM FEED & HIRE	DOG FOOD	1	55.00	
INV 0000089926/10/2017		NORTHAM FEED & HIRE	DOG TREATS	1	22.00	
EFT28236	13/11/2017	SCOPE TRAINING	CERTIFICATE IV IN PROCUREMENT & CONTRACTING PSP40616 RPL FOR LEASA OSBORNE.	1		2,520.00
INV IV00001509/11/2017		SCOPE TRAINING	CERTIFICATE IV IN PROCUREMENT & CONTRACTING PSP40616 RPL FOR LEASA OSBORNE.	1	2,520.00	
EFT28237	13/11/2017	SOUTHERN CROSS AUSTEREO PTY LTD	2 WEEK RADIO ADVERT CAMPAIGN FOR 2017 DOG'S DAY OUT.	1		602.80
INV 7054976731/10/2017		SOUTHERN CROSS AUSTEREO PTY LTD	2 WEEK RADIO ADVERT CAMPAIGN FOR 2017 DOG'S DAY OUT.	1	602.80	
EFT28238	13/11/2017	WESTERN AUSTRALIAN LOCAL GOVERNMENT ASSOCIATION	2017 WALGA PEOPLE & CULTURE SEMINAR 13/10/2017 - BEV JONES, ALYSHA MAXWELL & ANASTASIA WILLIAMS.	1		750.00
INV I3068001 17/10/2017		WESTERN AUSTRALIAN LOCAL GOVERNMENT ASSOCIATION	2017 WALGA PEOPLE & CULTURE SEMINAR 13/10/2017 - BEV JONES, ALYSHA MAXWELL & ANASTASIA WILLIAMS.	1	750.00	

Date: 01/12/2017
Time: 9:08:54AM

Shire of Northam

USER: Kathy Scholz
PAGE: 21

Cheque / EFT No	Date	Name	Invoice Description	Bank Code	INV Amount	Amount
EFT28239	14/11/2017	FIRM CONSTRUCTION PTY LTD	CONSTRUCTION OF THE ABORIGINAL & ENVIRONMENTAL INTERPRETIVE CENTRE - PROGRESS CLAIM 8 WORKS COMPLETED AS AT 27/10/2017.	1		467,461.35
INV 0000129427/10/2017	14/11/2017	FIRM CONSTRUCTION PTY LTD	CONSTRUCTION OF THE ABORIGINAL & ENVIRONMENTAL INTERPRETIVE CENTRE - PROGRESS CLAIM 8 WORKS COMPLETED AS AT 27/10/2017.	1	467,461.35	
EFT28240	14/11/2017	BUILDER'S REGISTRATION BOARD OF WA	MONTHLY BSL FEES COLLECTED FOR THE BUILDING COMMISSION FOR THE MONTH OF OCTOBER 2017	2		4,658.97
INV T995	14/11/2017	BUILDER'S REGISTRATION BOARD OF WA	MONTHLY BSL FEES COLLECTED FOR THE BUILDING COMMISSION FOR THE MONTH OF OCTOBER 2017	2	4,658.97	
EFT28241	14/11/2017	BUILDING AND CONSTRUCTION INDUSTRY TRAINING FUND	MONTHLY BCITF FEES COLLECTED FOR THE CONSTRUCTION TRAINING FUND FOR THE MONTH OF OCTOBER 2017.	2		6,972.67
INV T994	14/11/2017	BUILDING AND CONSTRUCTION INDUSTRY TRAINING FUND	MONTHLY BCITF FEES COLLECTED FOR THE CONSTRUCTION TRAINING FUND FOR THE MONTH OF OCTOBER 2017.	2	6,972.67	
EFT28242	14/11/2017	G ZUCCHETTO	REFUND OF BOND FOR 17116 BUILDING PERMIT.	2		1,000.00
INV T981	14/11/2017	G ZUCCHETTO	REFUND OF BOND FOR 17116 BUILDING PERMIT.	2	1,000.00	
EFT28243	14/11/2017	PHOEBE RYDER	REFUND OF BOND ON TOWN HALL BOOKING #3237 03/11/2017.	2		500.00
INV T1022	14/11/2017	PHOEBE RYDER	REFUND OF BOND ON TOWN HALL BOOKING #3237 03/11/2017.	2	500.00	
EFT28244	14/11/2017	SHIRE OF TOODYAY	AROC SECRETERIAT SUPPORT 2017/2018.	2		8,250.00
INV T957	14/11/2017	SHIRE OF TOODYAY	AROC SECRETERIAT SUPPORT 2017/2018.	2	8,250.00	
EFT28245	14/11/2017	ST JOSEPH'S SCHOOL PARENTS & FRIENDS ASSOCIATION	REFUND OF BOND ON BOOKING #3144.	2		100.00
INV T998	14/11/2017	ST JOSEPH'S SCHOOL PARENTS & FRIENDS ASSOCIATION	REFUND OF BOND ON BOOKING #3144.	2	100.00	
EFT28246	14/11/2017	WESTERN AUSTRALIAN LOCAL GOVERNMENT ASSOCIATION	SERVING ON COUNCIL ONSITE TRAINING - MEETING PROCEDURES AND DEBATING 27/10/2017.	2		8,690.00
INV T957	14/11/2017	WESTERN AUSTRALIAN LOCAL GOVERNMENT ASSOCIATION	SERVING ON COUNCIL ONSITE TRAINING - MEETING PROCEDURES AND DEBATING 27/10/2017.	2	8,690.00	

Date: 01/12/2017
Time: 9:08:54AM

Shire of Northam

USER: Kathy Scholz
PAGE: 22

Cheque / EFT No	Date	Name	Invoice Description	Bank Code	INV Amount	Amount
EFT28247	17/11/2017	ARTISTS REVOLUTION	FOUR DRAWINGS FOR INTERPRETIVE CENTER	1		300.00
INV #133	10/11/2017	ARTISTS REVOLUTION	FOUR DRAWINGS FOR INTERPRETIVE CENTER	1	300.00	
EFT28248	17/11/2017	AUSTRALIA POST	POSTAGE FOR ADMIN & KILLARA FOR OCTOBER 2017.	1		3,461.06
INV 1006899603/11/2017	17/11/2017	AUSTRALIA POST	POSTAGE FOR ADMIN & KILLARA FOR OCTOBER 2017.	1	3,461.06	
EFT28249	17/11/2017	AUSTRALIAN CIVILS PTY LTD	TEMPORARY FENCING FROM BERNARD PARK - 185 HEAVY DUTY FENCING PANELS, 145 BLOW MOULDED CONCRETE SUPPORT FEET & 180 GALVANISED CLAMPS.	1		4,400.00
INV 3017	13/11/2017	AUSTRALIAN CIVILS PTY LTD	TEMPORARY FENCING FROM BERNARD PARK - 185 HEAVY DUTY FENCING PANELS, 145 BLOW MOULDED CONCRETE SUPPORT FEET & 180 GALVANISED CLAMPS.	1	4,400.00	
EFT28250	17/11/2017	AUSTRALIAN TAXATION OFFICE - PAYG	PAYG PAY RUN WEEK END 14/11/2017.	1		60,627.00
INV PAYG 1414/11/2017	17/11/2017	AUSTRALIAN TAXATION OFFICE - PAYG	PAYG PAY RUN WEEK END 14/11/2017.	1	60,627.00	
EFT28251	17/11/2017	AVON VALLEY ARTS SOCIETY (INC)	STOCK PURCHASES FOR VISITORS CENTRE.	1		67.50
INV 0004797709/11/2017	17/11/2017	AVON VALLEY ARTS SOCIETY (INC)	STOCK PURCHASES FOR VISITORS CENTRE.	1	67.50	
EFT28252	17/11/2017	AVON VALLEY PLANT & EQUIPMENT PTY LTD	REPAIR CARTER ROAD CULVERT	1		3,223.00
INV IV10183	20/10/2017	AVON VALLEY PLANT & EQUIPMENT PTY LTD	REPAIR CARTER ROAD CULVERT	1	3,223.00	
EFT28253	17/11/2017	AVON YOUTH COMMUNITY AND FAMILY SERVICES	RATES REFUND FOR ASSESSMENT A11172 371 FITZGERALD STREET NORTHAM 6401	1		6,674.08
INV A11172	15/11/2017	AVON YOUTH COMMUNITY AND FAMILY SERVICES	RATES REFUND FOR ASSESSMENT A11172 371 FITZGERALD STREET NORTHAM 6401		2,852.52	
INV A12739	15/11/2017	AVON YOUTH COMMUNITY AND FAMILY SERVICES	RATES REFUND FOR ASSESSMENT A12739 39 ROBINSON STREET NORTHAM 6401		1,885.82	
INV A12166	15/11/2017	AVON YOUTH COMMUNITY AND FAMILY SERVICES	RATES REFUND FOR ASSESSMENT A12166 46 THROSSELL STREET NORTHAM 6401		1,935.74	
EFT28254	17/11/2017	AVW ELECTRICAL	CLACKLINE HALL, DISCONNECT HOT WATER SERVICE THEN CONNECT NEWLY INSTALLED.	1		159.50
INV A2145	08/11/2017	AVW ELECTRICAL	CLACKLINE HALL, DISCONNECT HOT WATER SERVICE THEN CONNECT NEWLY INSTALLED.	1	159.50	

Date: 01/12/2017
Time: 9:08:54AM

Shire of Northam

USER: Kathy Scholz
PAGE: 23

Cheque / EFT No	Date	Name	Invoice Description	Bank Code	INV Amount	Amount
EFT28255	17/11/2017	BEAUREPAIRES	TYRES FOR PN1501.	1		3,723.30
INV U524347925/10/2017		BEAUREPAIRES	REPLACE 2 TYRES ON KILLARA 2 - PN1202 KILLARA WHEELCHAIR BUS	1	1,113.78	
INV U524347923/10/2017		BEAUREPAIRES	REPAIR ON TYRE PN001	1	50.00	
INV U52434831/10/2017		BEAUREPAIRES	TYRES FOR PN1501.	1	2,559.52	
EFT28256	17/11/2017	BLUE FORCE PTY LTD	PROVISION OF CCTV INFRASTRUCTURE AS PER 4 OF 2016	1		23,715.03
INV 74330	31/08/2017	BLUE FORCE PTY LTD	PROVISION OF CCTV INFRASTRUCTURE AS PER 4 OF 2016	1	19,488.08	
INV 75056	29/09/2017	BLUE FORCE PTY LTD	PROVISION OF CCTV INFRASTRUCTURE AS PER 4 OF 2016	1	4,226.95	
EFT28257	17/11/2017	BOB WADDELL & ASSOCIATES PTY LTD	ASSISTANCE WITH HACC & CHSP ANNUAL REPORTS FOR KILLARA HOURLY RATE	1		3,333.00
INV 1218	13/11/2017	BOB WADDELL & ASSOCIATES PTY LTD	ASSISTANCE WITH HACC & CHSP ANNUAL REPORTS FOR KILLARA HOURLY RATE	1	264.00	
INV 1206	30/10/2017	BOB WADDELL & ASSOCIATES PTY LTD	ASSISTANCE WITH HACC & CHSP ANNUAL REPORTS FOR KILLARA HOURLY RATE	1	3,069.00	
EFT28258	17/11/2017	BOYD KICKETT	NORTHAM ABORIGINAL & ENVIRONMENTAL INTERPRETIVE CENTRE ABORIGINAL ADVISORY GROUP MEETING FEES 14/11/2017.	1		100.00
INV JW15112015/11/2017		BOYD KICKETT	NORTHAM ABORIGINAL & ENVIRONMENTAL INTERPRETIVE CENTRE ABORIGINAL ADVISORY GROUP MEETING FEES 14/11/2017.	1	100.00	
EFT28259	17/11/2017	CADD'S FASHIONS	KAYAK PADDLE FOR BOAT FOR ENGINEERING SERVICES.	1		50.00
INV 17-0000718/10/2017		CADD'S FASHIONS	KAYAK PADDLE FOR BOAT FOR ENGINEERING SERVICES.	1	50.00	
EFT28260	17/11/2017	CENTRAL REGIONAL TAFE	FEES FOR KATE BURTON & LEE-ELLEN FOMIATTI- PROCESS FINANCIAL TRANSACTIONS UNIT	1		460.12
INV I000275719/10/2017		CENTRAL REGIONAL TAFE	BOOKSHOP ITEMS FOR CERT IV HUMAN RESOURCES FOR ANASTASIA WILLIAMS	1	145.50	
INV I000297413/11/2017		CENTRAL REGIONAL TAFE	FEES FOR KATE BURTON & LEE-ELLEN FOMIATTI- PROCESS FINANCIAL TRANSACTIONS UNIT	1	314.62	
EFT28261	17/11/2017	CLACKLINE FENCING CONTRACTORS	REPAIR TO PERIMETER FENCE OF INKPEN WASTE FACILITY	1		300.00

Date: 01/12/2017
Time: 9:08:54AM

Shire of Northam

USER: Kathy Scholz
PAGE: 24

Cheque / EFT No	Date	Name	Invoice Description	Bank Code	INV Amount	Amount
INV 1115	14/11/2017	CLACKLINE FENCING CONTRACTORS	REPAIR TO PERIMETER FENCE OF INKPEN WASTE FACILITY	1	300.00	
EFT28262	17/11/2017	CLAIRE ESSMORE MCGUIRE	NORTHAM ABORIGINAL & ENVIRONMENTAL INTERPRETIVE CENTRE ABORIGINAL ADVISORY GROUP MEETING FEES 14/11/2017.	1		100.00
INV JW1511205/11/2017	17/11/2017	CLAIRE ESSMORE MCGUIRE	NORTHAM ABORIGINAL & ENVIRONMENTAL INTERPRETIVE CENTRE ABORIGINAL ADVISORY GROUP MEETING FEES 14/11/2017.	1	100.00	
EFT28263	17/11/2017	CONTRAFLOW PTY LTD	UPDATE TMP FOR 2017 XMAS ON FITZGERALD'S	1		165.00
INV T17/412930/10/2017	17/11/2017	CONTRAFLOW PTY LTD	UPDATE TMP FOR 2017 XMAS ON FITZGERALD'S	1	165.00	
EFT28264	17/11/2017	COUNTRYWIDE LANDSCAPING	BERNARD PARK RETICULATION UPGRADES COMPLETED 13TH OCTOBER 2017.	1		4,465.20
INV 23721	18/08/2017	COUNTRYWIDE LANDSCAPING	BERNARD PARK RETICULATION UPGRADES COMPLETED 13TH OCTOBER 2017.	1	4,465.20	
EFT28265	17/11/2017	COUNTRYWIDE POOLS	CHLORINE FOR NORTHAM POOL.	1		2,122.79
INV 24107	19/10/2017	COUNTRYWIDE POOLS	ROLL WHIPPER SNIPPER CORD FOR ENGINEERING SERVICES.	1	90.00	
INV 24226	01/11/2017	COUNTRYWIDE POOLS	10 X BPMR6A SPARK PLUGS FOR CHAINSAWS.	1	80.00	
INV 24210	30/10/2017	COUNTRYWIDE POOLS	5 X 20LT PUREX LIQUID CHLORINE FOR BAKERS HILL OVAL.	1	175.00	
INV 24194	26/10/2017	COUNTRYWIDE POOLS	CHLORINE FOR NORTHAM POOL	1	1,657.79	
INV 24120	20/10/2017	COUNTRYWIDE POOLS	CHAINSAW BAR OIL	1	120.00	
EFT28266	17/11/2017	DALLAS PHILLIPS	PROFESSIONAL FEES - TEXT DEVELOPMENT FOR EXHIBITION - AEIC.	1		150.00
INV RR1411204/11/2017	17/11/2017	DALLAS PHILLIPS	PROFESSIONAL FEES - TEXT DEVELOPMENT FOR EXHIBITION - AEIC.	1	150.00	
EFT28267	17/11/2017	DEBORAH MOODY	NORTHAM ABORIGINAL & ENVIRONMENTAL INTERPRETIVE CENTRE ABORIGINAL ADVISORY GROUP MEETING FEES 14/11/2017.	1		100.00
INV JW15112015/11/2017	17/11/2017	DEBORAH MOODY	NORTHAM ABORIGINAL & ENVIRONMENTAL INTERPRETIVE CENTRE ABORIGINAL ADVISORY GROUP MEETING FEES 14/11/2017.	1	100.00	

Date: 01/12/2017
Time: 9:08:54AM

Shire of Northam

USER: Kathy Scholz
PAGE: 25

Cheque / EFT No	Date	Name	Invoice Description	Bank Code	INV Amount	Amount
EFT28268	17/11/2017	DEPENDABLE LAUNDRY SOLUTIONS	TRAVEL TO SITE	1		511.50
INV 2017534827/10/2017	17/11/2017	DEPENDABLE LAUNDRY SOLUTIONS	CHECK COMMERCIAL WASHING MACHINE FOR LEAKS TRAVEL TO SITE CHECK COMMERCIAL WASHING MACHINE FOR LEAKS	1	511.50	
EFT28269	17/11/2017	DUNNING INVESTMENTS PTY LTD	FUEL CHARGES FOR OCTOBER 2017.	1		20,011.05
INV OCTOBE31/10/2017	17/11/2017	DUNNING INVESTMENTS PTY LTD	FUEL CHARGES FOR OCTOBER 2017.		20,011.05	
EFT28270	17/11/2017	EASIFLEET	Payroll deductions	1		1,064.47
INV DEDUCT14/11/2017	17/11/2017	EASIFLEET	Payroll deductions		783.95	
INV DEDUCT14/11/2017	17/11/2017	EASIFLEET	Payroll deductions		280.52	
EFT28271	17/11/2017	EASTERN HILLS SAWS & MOWERS	PULL START FOR BRIGGS & STRATTON PUMP MOTOR (608C).	1		115.00
INV 39965 # 431/10/2017	17/11/2017	EASTERN HILLS SAWS & MOWERS	PULL START FOR BRIGGS & STRATTON PUMP MOTOR (608C).	1	115.00	
EFT28272	17/11/2017	FLAT OUT FREIGHT	PICK UP CHAINS FROM THE RIGGING SHED AND RETURN TO SHIRE DEPOT	1		49.70
INV 0000624004/10/2017	17/11/2017	FLAT OUT FREIGHT	PICK UP CHAINS FROM THE RIGGING SHED AND RETURN TO SHIRE DEPOT	1	49.70	
EFT28273	17/11/2017	FULL BOAR SAFETY PTY LTD	PICK UP & REACHING TOOL SU001127	1		3,355.00
INV SINV058302/10/2017	17/11/2017	FULL BOAR SAFETY PTY LTD	PICK UP & REACHING TOOL SU001127	1	3,355.00	
EFT28274	17/11/2017	HOLLETT & LAWRENCE	RATES REFUND FOR ASSESSMENT A15284 12 GOLF CRESCENT NORTHAM 6401	1		816.41
INV A15284	15/11/2017	HOLLETT & LAWRENCE	RATES REFUND FOR ASSESSMENT A15284 12 GOLF CRESCENT NORTHAM 6401		816.41	
EFT28275	17/11/2017	IMMACU SWEEP	SWEEPING OF TOWN CENTRE FOOTPATHS 5 DAYS PER WEEK 23/10/2017 TO 28/10/2017.	1		16,117.20
INV 4342	01/11/2017	IMMACU SWEEP	SWEEPING OF TOWN CENTRE FOOTPATHS 5 DAYS PER WEEK 23/10/2017 TO 28/10/2017.	1	-4,029.30	
INV 4341	01/11/2017	IMMACU SWEEP	SWEEPING OF TOWN CENTRE FOOTPATHS 5 DAYS PER WEEK AS PER CONTRACT FOR THE PERIOD 16/10/2017 TO 21/10/2017.	1	-4,029.30	

Date: 01/12/2017
Time: 9:08:54AM

Shire of Northam

USER: Kathy Scholz
PAGE: 26

Cheque / EFT No	Date	Name	Invoice Description	Bank Code	INV Amount	Amount
INV 4340	01/11/2017	IMMACU SWEEP	SWEEPING OF TOWN CENTRE FOOTPATHS 5 DAYS PER WEEK AS PER CONTRACT FOR THE PERIOD 09/10/2017 TO 14/10/2017.	1	4,029.30	
INV 4339	01/11/2017	IMMACU SWEEP	SWEEPING OF TOWN CENTRE FOOTPATHS 5 DAYS PER WEEK AS PER CONTRACT FOR THE PERIOD 02/10/2017 TO 07/10/2017	1	4,029.30	
EFT28276	17/11/2017	IREDALE PEDERSEN HOOK ARCHITECTS	PROJECT MANAGEMENT - ABORIGINAL AND ENVIRONMENTAL INTERPRETIVE DESIGN	1		14,506.13
INV 0000479401/11/2017	17/11/2017	IREDALE PEDERSEN HOOK ARCHITECTS	PROJECT MANAGEMENT - ABORIGINAL AND ENVIRONMENTAL INTERPRETIVE DESIGN	1	1,175.63	
INV 0000479301/11/2017	17/11/2017	IREDALE PEDERSEN HOOK ARCHITECTS	PROJECT MANAGEMENT - ABORIGINAL AND ENVIRONMENTAL INTERPRETIVE DESIGN	1	3,074.50	
INV 0000479201/11/2017	17/11/2017	IREDALE PEDERSEN HOOK ARCHITECTS	PROJECT MANAGEMENT - ABORIGINAL AND ENVIRONMENTAL INTERPRETIVE DESIGN	1	2,310.00	
INV 0004791	01/11/2017	IREDALE PEDERSEN HOOK ARCHITECTS	PROJECT MANAGEMENT - ABORIGINAL AND ENVIRONMENTAL INTERPRETIVE DESIGN	1	675.00	
INV 0000479001/11/2017	17/11/2017	IREDALE PEDERSEN HOOK ARCHITECTS	PROJECT MANAGEMENT - ABORIGINAL AND ENVIRONMENTAL INTERPRETIVE DESIGN	1	7,271.00	
EFT28277	17/11/2017	JANET VOST	CURATORIAL SERVICES FOR NAEIC	1		2,716.00
INV 0017-4	10/11/2017	JANET VOST	CURATORIAL SERVICES FOR NAEIC	1	2,716.00	
EFT28278	17/11/2017	JITTO JOHN	CROSSOVER REBATE PAYMENT FOR 17 GOLF CRESCENT.	1		600.00
INV CK1411244/11/2017	17/11/2017	JITTO JOHN	CROSSOVER REBATE PAYMENT FOR 17 GOLF CRESCENT.	1	600.00	
EFT28279	17/11/2017	JONES CONTRACTING PTY LTD	140.80 TONNE OF 19MM SCREENED ROADBASE ON 02/10/17 DOCKET# 18232.	1		2,570.70
INV 3780	31/10/2017	JONES CONTRACTING PTY LTD	140.80 TONNE OF 19MM SCREENED ROADBASE ON 02/10/17 DOCKET# 18232.	1	1,548.60	
INV 3780	31/10/2017	JONES CONTRACTING PTY LTD	48.05 TONNE OF 19MM SCREENED ROAD BASED ON 20/10/217 DOCKET# 18350 FOR TRIMMER ROAD & 44.85 TONNE ON DOCKET# 17759 & 17763 FOR ROAD MAINTENANCE.	1	1,022.10	
EFT28280	17/11/2017	JTAGZ PTY LTD	DOG TAGS	1		158.40
INV 0000645106/11/2017	17/11/2017	JTAGZ PTY LTD	DOG TAGS	1	158.40	

Date: 01/12/2017
Time: 9:08:54AM

Shire of Northam

USER: Kathy Scholz
PAGE: 27

Cheque / EFT No	Date	Name	Invoice Description	Bank Code	INV Amount	Amount
EFT28281	17/11/2017	KATHY DAVIS	NORTHAM ABORIGINAL & ENVIRONMENTAL INTERPRETIVE CENTRE ABORIGINAL ADVISORY GROUP MEETING FEES 14/11/2017.	1		100.00
INV JW15112015/11/2017		KATHY DAVIS	NORTHAM ABORIGINAL & ENVIRONMENTAL INTERPRETIVE CENTRE ABORIGINAL ADVISORY GROUP MEETING FEES 14/11/2017.	1	100.00	
EFT28282	17/11/2017	KERBTECH P/L T/A GDR CIVIL CONTRACTING	HIRE OF FLOAT TO MOVE ROLLER FROM TROTting TRACK TO RACE TRACK AND FROM RACE TRACK TO LUNT STREET	1		1,320.00
INV 1241	19/10/2017	KERBTECH P/L T/A GDR CIVIL CONTRACTING	MOVE ROLLER FROM DEMPSTER TO MITCHELL AVENUE PARKING BAY.	1	330.00	
INV 1244	25/10/2017	KERBTECH P/L T/A GDR CIVIL CONTRACTING	HIRE OF FLOAT TO MOVE ROLLER FROM TROTting TRACK TO RACE TRACK AND FROM RACE TRACK TO LUNT STREET	1	660.00	
INV 1245	26/10/2017	KERBTECH P/L T/A GDR CIVIL CONTRACTING	HIRE OF FLOAT TO MOVE ROLLER FROM NORTHAM AIRFIELD TO THROSSELL STREET	1	330.00	
EFT28283	17/11/2017	LEISURE INSTITUTE OF W A AQUATICS	RENEWAL OF MEMBERSHIP FEES FOR POOL SEASON 2017-2018 FOR KIM JOHNSON.	1		120.00
INV 2283	06/11/2017	LEISURE INSTITUTE OF W A AQUATICS	RENEWAL OF MEMBERSHIP FEES FOR POOL SEASON 2017-2018 FOR KIM JOHNSON.	1	120.00	
EFT28284	17/11/2017	LLOYD INVESTMENT GROUP	AV FOR 2017 SENIORS GALA CONCERT	1		700.00
INV 0001032730/10/2017		LLOYD INVESTMENT GROUP	AV FOR 2017 SENIORS GALA CONCERT	1	700.00	
EFT28285	17/11/2017	LOCAL GOVERNMENT AND RACECOURSE EMPLOYEES UNION	Payroll deductions	1		20.50
INV DEDUCT14/11/2017		LOCAL GOVERNMENT AND RACECOURSE EMPLOYEES UNION	Payroll deductions		20.50	
EFT28286	17/11/2017	MARIA NICKELS	NORTHAM ABORIGINAL & ENVIRONMENTAL INTERPRETIVE CENTRE ABORIGINAL ADVISORY GROUP MEETING FEES 14/11/2017.	1		100.00
INV JW15112015/11/2017		MARIA NICKELS	NORTHAM ABORIGINAL & ENVIRONMENTAL INTERPRETIVE CENTRE ABORIGINAL ADVISORY GROUP MEETING FEES 14/11/2017.	1	100.00	
EFT28287	17/11/2017	MATHEW MACQUEEN	FIREBREAK INSPECTIONS FOR THE 2017/2018 FIRE SEASON.	1		3,355.00

Date: 01/12/2017
Time: 9:08:54AM

Shire of Northam

USER: Kathy Scholz
PAGE: 28

Cheque / EFT No	Date	Name	Invoice Description	Bank Code	INV Amount	Amount
INV 639	10/11/2017	MATHEW MACQUEEN	FIREBREAK INSPECTIONS FOR THE 2017/2018 FIRE SEASON.	1	3,355.00	
EFT28288	17/11/2017	MAYBERRY HAMMOND & CO	LEASE AGREEMENT FOR HANGAR 31	1		693.00
INV 40634	23/06/2017	MAYBERRY HAMMOND & CO	DEED OF SURRENDER FOR BASHAM HANGAR 6	1	231.00	
INV 40937	07/11/2017	MAYBERRY HAMMOND & CO	LEASE AGREEMENT FOR HANGAR 31	1	462.00	
EFT28289	17/11/2017	MCDOWALL AFFLECK PTY LTD	KING CREEK STAGE 3 SITE INSPECTIONS AND CONSTRUCTION SUPPORT 27 SEPTEMBER TO 25 OCTOBER 2017.	1		2,161.50
INV 608227	25/10/2017	MCDOWALL AFFLECK PTY LTD	KING CREEK STAGE 3 SITE INSPECTIONS AND CONSTRUCTION SUPPORT 27 SEPTEMBER TO 25 OCTOBER 2017.	1	2,161.50	
EFT28290	17/11/2017	MICHAEL PATRICK RYAN	REIMBURSEMENT IF ITUNES VOUCHERS LOADED TO COUNCILLOR 2 ACCOUNT TO PURCHASE AP "LIQUID TEXT PRO" PDF READER.	1		60.00
INV JW13112013/11/2017	17/11/2017	MICHAEL PATRICK RYAN	REIMBURSEMENT IF ITUNES VOUCHERS LOADED TO COUNCILLOR 2 ACCOUNT TO PURCHASE AP "LIQUID TEXT PRO" PDF READER.	1	60.00	
EFT28291	17/11/2017	MIDLAND MOWERS	PART S FOR LAWN MOWERS.	1		1,300.51
INV 24490#4	08/11/2017	MIDLAND MOWERS	DISCHARGE CHUTE 61 IN.	1	61.65	
INV 24476#4	07/11/2017	MIDLAND MOWERS	PART S FOR LAWN MOWERS.	1	1,238.86	
EFT28292	17/11/2017	MOORE STEPHENS (WA) PTY LTD	ADDITIONAL TIME SPEND ON THE AUDIT OF THE FINANACIAL REPORT FIR THE YEAR ENDED 30 JUNE 2017.	1		2,491.50
INV 304650	14/11/2017	MOORE STEPHENS (WA) PTY LTD	ADDITIONAL TIME SPEND ON THE AUDIT OF THE FINANACIAL REPORT FIR THE YEAR ENDED 30 JUNE 2017.	1	2,491.50	
EFT28293	17/11/2017	MORRIS PEST AND WEED CONTROL	SPRAY WUNDOWIE & BAKERS HILL OVAL WITH KAMBA M AND LONTREL	1		1,696.00
INV 8439	03/11/2017	MORRIS PEST AND WEED CONTROL	SPRAY WUNDOWIE & BAKERS HILL OVAL WITH KAMBA M AND LONTREL	1	1,696.00	
EFT28294	17/11/2017	NORTHAM DISCOLNT DRUG STORE	MEDICATION FOR CLIENTS AT KILLARA.	1		124.38

Date: 01/12/2017
Time: 9:08:54AM

Shire of Northam

USER: Kathy Scholz
PAGE: 29

Cheque / EFT No	Date	Name	Invoice Description	Bank Code	INV Amount	Amount
INV 968217	10/11/2017	NORTHAM DISCOUNT DRUG STORE	MEDICATION FOR CLIENTS AT KILLARA.	1	124.38	
EFT28295	17/11/2017	NORTHAM THEATRE GROUP	GRANT FOR COSTS INCURRED WITH THE NORTHAM PERFORMING ARTS FESTIVAL 2018 & GRANT FOR PRODUCTION PERFORMING RIGHTS.	1		3,000.00
INV 00230	05/11/2017	NORTHAM THEATRE GROUP	GRANT FOR COSTS INCURRED WITH THE NORTHAM PERFORMING ARTS FESTIVAL 2018 & GRANT FOR PRODUCTION PERFORMING RIGHTS.	1	3,000.00	
EFT28296	17/11/2017	OCTAGON-BKG LIFTS	NORTHAM LIBRARY - ATTEND SITE ON TUESDAY 31ST OCTOBER 2017 AT 9:00AM TO COMPLETE ROUTINE MAINTENANCE ON CIBESLIFT A5000 HANDICAPPED ACCESS PLATFORM.	1		655.60
INV 0001533107/11/2017		OCTAGON-BKG LIFTS	NORTHAM LIBRARY - ATTEND SITE ON TUESDAY 31ST OCTOBER 2017 AT 9:00AM TO COMPLETE ROUTINE MAINTENANCE ON CIBESLIFT A5000 HANDICAPPED ACCESS PLATFORM.	1	655.60	
EFT28297	17/11/2017	OXTER SERVICES	CLEANING AT VARIOUS SHIRE TOILETS.	1		4,345.00
INV 18847	03/11/2017	OXTER SERVICES	CLEANING AT VARIOUS SHIRE TOILETS.	1	3,564.00	
INV 18849	03/11/2017	OXTER SERVICES	NEW GRAVE FOR THE BURIAL OF RUSSELL RYDER 3/11/2017.	1	781.00	
EFT28298	17/11/2017	RAPID CRUSHING & SCREENING CONTRACTORS PTY LTD	RATES REFUND FOR ASSESSMENT A16276 5 SELICK DRIVE WUNDOWIE WA 6560	1		1,752.25
INV A16276	15/11/2017	RAPID CRUSHING & SCREENING CONTRACTORS PTY LTD	RATES REFUND FOR ASSESSMENT A16276 5 SELICK DRIVE WUNDOWIE WA 6560.		1,752.25	
EFT28299	17/11/2017	REGIONAL PHYSIOTHERAPY & SPORTS INJURY CLINIC & IN BALANCE FITNESS	SENIOR SPORT FUNDING	1		150.00
INV 0013150	09/11/2017	REGIONAL PHYSIOTHERAPY & SPORTS INJURY CLINIC & IN BALANCE FITNESS	SENIOR SPORT FUNDING	1	150.00	
EFT28300	17/11/2017	RETAIL DECISIONS (COLES)	COLES CARDS FOR OCTOBER 2017 - MILTON BROOKS, SUSAN BURLEY, BEV BULL, ALISON ROWLAND, CHRISTINE WATERS, KRISTY ROBINSON, ALYSHA MAXWELLM WENDY SOPOULIS, KIM COLBOURNE, VICTORIA JONES.	1		4,005.27

Date: 01/12/2017
Time: 9:08:54AM

Shire of Northam

USER: Kathy Scholz
PAGE: 30

Cheque / EFT No	Date	Name	Invoice Description	Bank Code	INV Amount	Amount
INV OCTOBE31/10/2017		RETAIL DECISIONS (COLES)	COLES CARDS FOR OCTOBER 2017 - MILTON BROOKS, SUSAN BURLEY, BEV BULL, ALISON ROWLAND, CHRISTINE WATERS, KRISTY ROBINSON, ALYSHA MAXWELLM WENDY SOPOULIS, KIM COLBOURNE, VICTORIA JONES.	1	4,005.27	
EFT28301	17/11/2017	ROAD AND TRAFFIC SERVICES	INSTALL PAVEMENT MARKINGS AS PER DRAWING SUPPLIED WELLINGTON STREET (OPPOSITE COURTHOUSE).	1		1,639.00
INV 0000710419/10/2017		ROAD AND TRAFFIC SERVICES	INSTALL PAVEMENT MARKINGS AS PER DRAWING SUPPLIED WELLINGTON STREET (OPPOSITE COURTHOUSE).	1	1,639.00	
EFT28302	17/11/2017	RURAL PRESS REGIONAL MEDIA (WA) PTY LTD	MONTHLY NEWSLETTER FULL PAGE AD	1		5,063.42
INV 5180692	02/08/2017	RURAL PRESS REGIONAL MEDIA (WA) PTY LTD	1/4 PAGE ADVERTISING IN AVON VALLEY ADVOCATE AUGUST 2ND EDITIONS.	1	218.22	
INV 5222741	02/08/2017	RURAL PRESS REGIONAL MEDIA (WA) PTY LTD	INCLUSION INTO 2017 AVON DESCENT WRAP	1	800.00	
INV 5224165	02/08/2017	RURAL PRESS REGIONAL MEDIA (WA) PTY LTD	MONTHLY NEWSLETTER FULL PAGE AD	1	997.57	
INV 5224166	02/08/2017	RURAL PRESS REGIONAL MEDIA (WA) PTY LTD	QUARTERLY REPORT -	1	997.57	
INV 5180693	16/08/2017	RURAL PRESS REGIONAL MEDIA (WA) PTY LTD	1/4 ADVERT INSERTION INTO AVON VALLEY ADVOCATE,	1	218.22	
INV 5232249	16/08/2017	RURAL PRESS REGIONAL MEDIA (WA) PTY LTD	ADVERT IN THE AVON VALLEY ADVOCATE ON 16/08/2017 FOR THE LOCAL GOVERNMENT ORDINARY ELECTION	1	349.27	
INV 5238051	30/08/2017	RURAL PRESS REGIONAL MEDIA (WA) PTY LTD	1/4 ADVERT INSERTION INTO AVON VALLEY ADVOCATE	1	485.00	
INV 5238443	30/08/2017	RURAL PRESS REGIONAL MEDIA (WA) PTY LTD	MONTHLY NEWSLETTER FULL PAGE AD	1	997.57	
EFT28303	17/11/2017	SCHWEPPE PTY LTD	GATORADE & WATER FOR NOTHAM REC CENTRE.	1		436.38
INV 1900142423/10/2017		SCHWEPPE PTY LTD	GATORADE & WATER FOR NOTHAM REC CENTRE.	1	436.38	
EFT28304	17/11/2017	ST JOHN AMBULANCE AUSTRALIA	FIRST AID GRAB BAG FOR VARIOUS SITES.	1		480.00
INV CYINVOC19/07/2017		ST JOHN AMBULANCE AUSTRALIA	FIRST AID GRAB BAG FOR VARIOUS SITES.	1	480.00	

Date: 01/12/2017
Time: 9:08:54AM

Shire of Northam

USER: Kathy Scholz
PAGE: 31

Cheque / EFT No	Date	Name	Invoice Description	Bank Code	INV Amount	Amount
INV CYINV0016/05/2017		ST JOHN AMBULANCE AUSTRALIA	SERVICING FIRST AID KITS AT KILLARA.	1	82.86	
INV CYRTN018/05/2017		ST JOHN AMBULANCE AUSTRALIA	CREDIT NOTE ISSUED AS TWO TAX INVOICES WERE ISSUED TO SERVICE THE FIRST AID KITS AT KILLARA REFERS TO TAX INVOICE# CYINV00012576.	1	-55.00	
INV CYRTN014/11/2017		ST JOHN AMBULANCE AUSTRALIA	CREDIT NOTE ISSUED AS TWO TAX INVOICES WERE ISSUED TO SERVICE THE FIRST AID KITS AT KILLARA REFERS TO TAX INVOICE# CYINV00012576.	1	-27.86	
EFT28305	17/11/2017	THE WATERSHED	IRRIGATION PARTS FOR BERNARD PARK WATER FEATURE	1		239.75
INV 1015649827/10/2017		THE WATERSHED	IRRIGATION PARTS FOR BERNARD PARK WATER FEATURE	1	239.75	
EFT28306	17/11/2017	TOWN PLANNING URBAN DESIGN AND HERITAGE	PREPARATION OF THE CBD DEVELOPMENT AND CONNECTIVITY STRATEGY - PROJECT GENERAL - TASK 6 (PHASE 7) PUBLIC SUBMISSION PERIOD.	1		1,956.72
INV 44834	31/10/2017	TOWN PLANNING URBAN DESIGN AND HERITAGE	PREPARATION OF THE CBD DEVELOPMENT AND CONNECTIVITY STRATEGY - PROJECT GENERAL - TASK 6 (PHASE 7) PUBLIC SUBMISSION PERIOD.	1	1,956.72	
EFT28307	17/11/2017	TYRECYCLE PTY LTD	RUBBER TRACK MEDIUM TYRE	1		440.00
INV 656904	20/10/2017	TYRECYCLE PTY LTD	RUBBER TRACK MEDIUM TYRE	1	440.00	
EFT28308	17/11/2017	VODAFONE	HARVEST BAN LINE 01/11/2017 TO 30/11/2017.	1		289.52
INV 1117951706/11/2017		VODAFONE	HARVEST BAN LINE 01/11/2017 TO 30/11/2017.	1	289.52	
EFT28309	17/11/2017	WARCA INC	WARCA MEMBERSHIP FEE 2017/2018	1		9,350.00
INV 18	09/11/2017	WARCA INC	WARCA MEMBERSHIP FEE 2017/2018	1	9,350.00	
EFT28310	17/11/2017	WARRICKS NEWSAGENCY	STATIONERY ORDER FOR KILLARA	1		196.35
INV 48071	13/10/2017	WARRICKS NEWSAGENCY	STATIONERY ORDER FOR KILLARA	1	196.35	
EFT28311	17/11/2017	WESTWIDE AUTO ELECTRICS AND AIR CONDITIONING	PN1201 - AIR CON NOT WORKING, RADIO NOT WORKING, REVERSE CAMERA NOT WORKING	1		1,388.00
INV 7294	06/10/2017	WESTWIDE AUTO ELECTRICS AND AIR CONDITIONING	PN1201 - AIR CON NOT WORKING, RADIO NOT WORKING, REVERSE CAMERA NOT WORKING	1	936.00	
INV 7292	09/10/2017	WESTWIDE AUTO ELECTRICS AND AIR CONDITIONING	PN1603 - REPAIR REMOTE FOR SWEEPER	1	276.00	

Date: 01/12/2017
Time: 9:08:54AM

Shire of Northam

USER: Kathy Scholz
PAGE: 32

Cheque / EFT No	Date	Name	Invoice Description	Bank Code	INV Amount	Amount
INV 7291	09/10/2017	WESTWIDE AUTO ELECTRICS AND AIR CONDITIONING	ASSESS AND RECTIFY TAIL LIGHTS NOT WORKING (PN1611)	1	176.00	
EFT28312	17/11/2017	WRIGHT EXPRESS AUSTRALIA PTY LTD (PUMA ENERGY)	FUEL PURCHASED FROM PUMA - OCTOBER 2017.	1		1,973.04
INV OCTOBE31/10/2017		WRIGHT EXPRESS AUSTRALIA PTY LTD (PUMA ENERGY)	FUEL PURCHASED FROM PUMA - OCTOBER 2017.	1	1,973.04	
EFT28313	17/11/2017	YVONNE KICKETT	NORTHAM ABORIGINAL & ENVIRONMENTAL INTERPRETIVE CENTRE ABORIGINAL ADVISORY GROUP MEETING FEES 14/11/2017.	1		100.00
INV JW15112015/11/2017		YVONNE KICKETT	NORTHAM ABORIGINAL & ENVIRONMENTAL INTERPRETIVE CENTRE ABORIGINAL ADVISORY GROUP MEETING FEES 14/11/2017.	1	100.00	
EFT28314	22/11/2017	ATTILA JOHN MENCSELYI	REFUND OF 2017 ELECTION NOMINATIONS	2		80.00
INV T1002	22/11/2017	ATTILA JOHN MENCSELYI	REFUND OF 2017 ELECTION NOMINATIONS	2	80.00	
EFT28315	22/11/2017	CARL PHILLIP DELLA	REFUND OF 2017 ELECTION NOMINATIONS	2		80.00
INV T1009	22/11/2017	CARL PHILLIP DELLA	REFUND OF 2017 ELECTION NOMINATIONS	2	80.00	
EFT28316	22/11/2017	COLIN DAVID HASSELL	REFUND OF 2017 ELECTION NOMINATIONS	2		80.00
INV T1011	22/11/2017	COLIN DAVID HASSELL	REFUND OF 2017 ELECTION NOMINATIONS	2	80.00	
EFT28317	22/11/2017	DENIS GRAHAM BERESFORD	REFUND OF 2017 ELECTION NOMINATIONS	2		80.00
INV T1004	22/11/2017	DENIS GRAHAM BERESFORD	REFUND OF 2017 ELECTION NOMINATIONS	2	80.00	
EFT28318	22/11/2017	DESMOND ARNOLD HUGHES	REFUND OF 2017 ELECTION NOMINATIONS	2		80.00
INV T1006	22/11/2017	DESMOND ARNOLD HUGHES	REFUND OF 2017 ELECTION NOMINATIONS	2	80.00	
EFT28319	22/11/2017	MICHAEL PATRICK RYAN	REFUND OF 2017 ELECTION NOMINATIONS	2		80.00
INV T1001	22/11/2017	MICHAEL PATRICK RYAN	REFUND OF 2017 ELECTION NOMINATIONS	2	80.00	
EFT28320	22/11/2017	STEVEN BRUCE POLLARD	REFUND OF 2017 ELECTION NOMINATIONS	2		80.00
INV T1010	22/11/2017	STEVEN BRUCE POLLARD	REFUND OF 2017 ELECTION NOMINATIONS	2	80.00	

Date: 01/12/2017
Time: 9:08:54AM

Shire of Northam

USER: Kathy Scholz
PAGE: 33

Cheque / EFT No	Date	Name	Invoice Description	Bank Code	INV Amount	Amount
EFT28321	22/11/2017	TERRY MATTHEW LITTLE	REFUND OF 2017 ELECTION NOMINATIONS	2		80.00
INV T1003	22/11/2017	TERRY MATTHEW LITTLE	REFUND OF 2017 ELECTION NOMINATIONS	2	80.00	
EFT28322	22/11/2017	ULO RUMJANTSEV	REFUND OF 2017 ELECTION NOMINATIONS	2		80.00
INV T1005	22/11/2017	ULO RUMJANTSEV	REFUND OF 2017 ELECTION NOMINATIONS	2	80.00	
EFT28323	23/11/2017	AVON VALLEY VINTAGE VEHICLE ASSOCIATION OF WA INC	COMMUNITY GRANT 2017/2018.	1		3,300.00
INV SJ00001415/11/2017	23/11/2017	AVON VALLEY VINTAGE VEHICLE ASSOCIATION OF WA INC	COMMUNITY GRANT 2017/2018.	1	3,300.00	
EFT28324	23/11/2017	ANDY'S PLUMBING SERVICE	CLACKLINE HALL. REPLACE HOT WATER UNIT AS PER QUOTE 02/11/2017.	1		2,062.50
INV A17786	10/11/2017	ANDY'S PLUMBING SERVICE	BERNARD PARK TOILETS. UNBLOCK MALE TOILET AND SEVICE ALL URINALS.	1	390.50	
INV A17785	10/11/2017	ANDY'S PLUMBING SERVICE	CLACKLINE HALL. REPAIR HWS CUTTING IN AND OUT.	1	297.00	
INV A17784	10/11/2017	ANDY'S PLUMBING SERVICE	CLACKLINE HALL. REPLACE HOT WATER UNIT AS PER QUOTE 02/11/2017.	1	1,375.00	
EFT28325	23/11/2017	AVON PAPER SHRED	EMPTYING OF ADMIN SHREDDER BIN	1		60.00
INV 677	08/11/2017	AVON PAPER SHRED	EMPTYING OF ADMIN SHREDDER BIN	1	60.00	
EFT28326	23/11/2017	AVON VALLEY CONTRACTORS	HIRE OF GRADER FROM 1 SEPTEMBER 2017 TO 30 SEPTEMBER 2017 @ \$500 PER DAY WHILST GRADER IS UNDER REPAIRS (16 DAYS)- LESS TRAINING DAYS, RDO, PUBLIC HOLIDAY AND WEEKENDS	1		3,300.00
INV 2048	09/11/2017	AVON VALLEY CONTRACTORS	HIRE OF GRADER FROM 1 SEPTEMBER 2017 TO 30 SEPTEMBER 2017 @ \$500 PER DAY WHILST GRADER IS UNDER REPAIRS (16 DAYS)- LESS TRAINING DAYS, RDO, PUBLIC HOLIDAY AND WEEKENDS	1	3,300.00	
EFT28327	23/11/2017	BALLANTYNES JEWELLERS	JEWELRY GIFT FOR STACEY SARGEANT (GOING AWAY)	1		480.00
INV 001-3278:16/11/2017	23/11/2017	BALLANTYNES JEWELLERS	JEWELRY GIFT FOR STACEY SARGEANT (GOING AWAY)	1	480.00	
EFT28328	23/11/2017	BLOOMY'S FLORIST	WREATHS FOR REMEMBERANCE DAY SERVICES (BAKERS HILL, WUNDOWIE AND NORTHAM)	1		180.00

Date: 01/12/2017
Time: 9:08:54AM

Shire of Northam

USER: Kathy Scholz
PAGE: 34

Cheque / EFT No	Date	Name	Invoice Description	Bank Code	INV Amount	Amount
INV 18874	09/11/2017	BLOOMY'S FLORIST	WREATHS FOR REMEMBERANCE DAY SERVICES (BAKERS HILL, WUNDOWIE AND NORTHAM)	1	180.00	
EFT28329	23/11/2017	CLACKLINE FENCING CONTRACTORS	RIVERBANK FENCING BROOME TERRACE - SHIRE OF NORTHAM TO ARRANGE REMOVAL & DISPOSAL OF EXISTING RAIL TYPE FENCING ALONG FOOTPATH. SUPPLY & INSTALL APPROX 350.00M BLACK PVC/POWDERCOATED CHAINMESH FENCING AT 1200MM WITH LACED TOP & BOTTOM RAILING (INCLUDES (3) STAIRWELL APPLICATIONS AS PER QUOTE: Q_NSC.BROOMETERRACERE VISED.2017 DATED 23/03/2017.	1		36,789.80
INV 1116	14/11/2017	CLACKLINE FENCING CONTRACTORS	RIVERBANK FENCING BROOME TERRACE - SHIRE OF NORTHAM TO ARRANGE REMOVAL & DISPOSAL OF EXISTING RAIL TYPE FENCING ALONG FOOTPATH. SUPPLY & INSTALL APPROX 350.00M BLACK PVC/POWDERCOATED CHAINMESH FENCING AT 1200MM WITH LACED TOP & BOTTOM RAILING (INCLUDES (3) STAIRWELL APPLICATIONS AS PER QUOTE: Q_NSC.BROOMETERRACERE VISED.2017 DATED 23/03/2017.	1	36,789.80	
EFT28330	23/11/2017	CLACKLINE/TOODYAY KARATE CLUB INC	KIDSPORT FUNDING	1		400.00
INV KS01498(15/11/2017		CLACKLINE/TOODYAY KARATE CLUB INC	KIDSPORT FUNDING	1	400.00	
EFT28331	23/11/2017	COLIN DUNCAN GRANT	CLEANING OF NORTHAM RECREATION CENTRE 2/09/2017	1		330.00
INV P884	02/11/2017	COLIN DUNCAN GRANT	CLEANING OF NORTHAM RECREATION CENTRE 2/11/2017	1	165.00	
INV P881	02/09/2017	COLIN DUNCAN GRANT	CLEANING OF NORTHAM RECREATION CENTRE 2/09/2017	1	165.00	
EFT28332	23/11/2017	COMISKEY'S CONTRACTING PTY LTD	CONTRACT 2 OF 2017 - KING CREEK DRAIN STAGE 3 CONSTRUCTION	1		100,661.93
INV 171101	25/10/2017	COMISKEY'S CONTRACTING PTY LTD	CONTRACT 2 OF 2017 - KING CREEK DRAIN STAGE 3 CONSTRUCTION	1	100,661.93	
EFT28333	23/11/2017	COUNTRY COMFORTSTYLE NORTHAM	STORAGE CABINETS & BOOKCASES.	1		1,521.00
INV 4034	25/10/2017	COUNTRY COMFORTSTYLE NORTHAM	FURNITURE FOR LIBRARY	1	521.00	
INV 4035	25/10/2017	COUNTRY COMFORTSTYLE NORTHAM	STORAGE CABINETS & BOOKCASES.	1	1,000.00	

Date: 01/12/2017
Time: 9:08:54AM

Shire of Northam

USER: Kathy Scholz
PAGE: 35

Cheque / EFT No	Date	Name	Invoice Description	Bank Code	INV Amount	Amount
EFT28334	23/11/2017	DEPARTMENT OF LOCAL GOVERNMENT, SPORT & CULTURAL INDUSTRIES	UNSPENT CLGF YOUTH DEVELOPMENT SCHOLARSHIP FUNDS FOR DAVID SLATER (ROUND 3 2016/2017)	1		9,900.00
INV 0000059015/09/2017		DEPARTMENT OF LOCAL GOVERNMENT, SPORT & CULTURAL INDUSTRIES	UNSPENT CLGF YOUTH DEVELOPMENT SCHOLARSHIP FUNDS FOR DAVID SLATER (ROUND 3 2016/2017)	1	9,900.00	
EFT28335	23/11/2017	E FIRE & SAFETY	MONTHLY FIRE PANEL TEST FOR OCTOBER - REC CENTRE.	1		412.50
INV 0021006025/10/2017		E FIRE & SAFETY	TOWN HALL. MONTHLY FIRE PANEL TEST FOR OCTOBER 2017.	1	126.50	
INV 0021007125/10/2017		E FIRE & SAFETY	MONTHLY FIRE PANEL TEST FOR OCTOBER AT KILLARA.	1	126.50	
INV 0021007325/10/2017		E FIRE & SAFETY	MONTHLY FIRE PANEL TEST FOR OCTOBER - REC CENTRE.	1	159.50	
EFT28336	23/11/2017	EMERG SOLUTIONS PTY LTD	BART APP - LICENCES FOR 80 USERS SHIRE OF NORTHAM BUSHFIRE BRIGADES	1		1,200.00
INV INV-068521/11/2017		EMERG SOLUTIONS PTY LTD	BART APP - LICENCES FOR 80 USERS SHIRE OF NORTHAM BUSHFIRE BRIGADES	1	1,200.00	
EFT28337	23/11/2017	FULTON HOGAN INDUSTRIES PTY LTD	1000L - IBC OF EMULSION	1		4,478.36
INV 1108070924/10/2017		FULTON HOGAN INDUSTRIES PTY LTD	3T OF 7MM DENSE GRADE BLACK ASPHALT	1	617.36	
INV 1110140630/10/2017		FULTON HOGAN INDUSTRIES PTY LTD	1000L - IBC OF EMULSION	1	3,861.00	
EFT28338	23/11/2017	GLENN STUART BEVERIDGE	REPAIR WHITE ANT DAMAGED POST & RAILS ON OLD YORK ROAD BRIDGE.	1		6,714.40
INV 541	14/11/2017	GLENN STUART BEVERIDGE	WUNDOWIE LIBRARY. REPAIR LATCH GUARD ON EXTERIOR DOOR.	1	229.90	
INV 540	14/11/2017	GLENN STUART BEVERIDGE	SUSPENSION BRIDGE. REPLACE 12 X DAMAGED BOARDS.	1	957.00	
INV 543	20/11/2017	GLENN STUART BEVERIDGE	NORTHAM DEPOT. RAISE THE HEIGHT OF SHELVES IN JOHNS OFFICE. INSTALL NEW WHITE BOARD IN JOHNS OFFICE, BOARD AT SHANES BUILDING. REPAIR FRONT DOOR LOCK. REPAIR SHELF IN SANTOS OFFICE.	1	264.00	
INV 544	20/11/2017	GLENN STUART BEVERIDGE	FIX HOLES AND CRACKS IN GYPROCK WALL ABOVE STADIUM and REPLACE BROKEN COACH HOOK ON STORAGE UNDER STADIUM	1	319.00	
INV 545	20/11/2017	GLENN STUART BEVERIDGE	ADMIN BUILDING. RELOCATE SAFE AND CUPBOARD, VARIOUS PIN UP BOARD INSTALLATION, OTHER MINOR REPAIRS.	1	511.50	

Date: 01/12/2017
Time: 9:08:54AM

Shire of Northam

USER: Kathy Scholz
PAGE: 36

Cheque / EFT No	Date	Name	Invoice Description	Bank Code	INV Amount	Amount
INV 547	20/11/2017	GLENN STUART BEVERIDGE	NORTHAM LIBRARY RELOCATE OFFICE EQUIPMENT AND HANG PICTURES.	1	297.00	
INV 515	23/10/2017	GLENN STUART BEVERIDGE	REPAIR SHADE SAIL AT FLUFFY DUCKS DAY CARE - REPLACE ATTACHMENTS	1	132.00	
INV 520	27/10/2017	GLENN STUART BEVERIDGE	REMOVE DAMAGED SHADE SAIL FROM GRASS VALLEY PARK AND DELIVER TO OLLY'S UPHOLSTERERS FOR REPAIRS.	1	264.00	
INV 37	08/11/2017	GLENN STUART BEVERIDGE	REINSTALL ONCE REPAIRED. REPAIR WHITE ANT DAMAGED POST & RAILS ON OLD YORK ROAD BRIDGE.	1	3,740.00	
EFT28339	23/11/2017	GROVE WESLEY DESIGN ART	2000 CHRISTMAS ON FITZGERALD FLYERS	1		407.00
INV 4767	20/11/2017	GROVE WESLEY DESIGN ART	2000 CHRISTMAS ON FITZGERALD FLYERS	1	407.00	
EFT28340	23/11/2017	HIRE KING	4 X COCKTAIL GLOW TABLES AND 16 X GLOW CUBE SEATS FOR 2017 BALLOON FIESTA VIP FUNCTION	1		860.00
INV 019609	04/09/2017	HIRE KING	4 X COCKTAIL GLOW TABLES AND 16 X GLOW CUBE SEATS FOR 2017 BALLOON FIESTA VIP FUNCTION	1	860.00	
EFT28341	23/11/2017	HOST AUTO REPAIRS	ANNUAL SERVICE & MAINTENANCE OF 1GAZ650 - ISUZU GRASS VALLEY BUSH FIRE BRIGADES.	1		630.30
INV 61099	07/11/2017	HOST AUTO REPAIRS	ANNUAL SERVICE & MAINTENANCE OF 1GAZ650 - ISUZU GRASS VALLEY BUSH FIRE BRIGADES.	1	630.30	
EFT28342	23/11/2017	JENNIFER MAHER	REIMBURSEMENT FOR POLICE CLEARANCE APPLICATION.	1		52.60
INV 2272276	15/11/2017	JENNIFER MAHER	REIMBURSEMENT FOR POLICE CLEARANCE APPLICATION.	1	52.60	
EFT28343	23/11/2017	KIM COLBOURNE	COUCH COVER FOR CHILDRENS LIBRARY & DESK FOR CATALOGUE COMPUTER.	1		392.95
INV RR15112(15/11/2017		KIM COLBOURNE	IMAC COMPUTER - FOR CHILDRENS LIBRARY.	1	153.95	
INV 5100440511(11/2017		KIM COLBOURNE	COUCH COVER FOR CHILDRENS LIBRARY & DESK FOR CATALOGUE COMPUTER.	1	239.00	
EFT28344	23/11/2017	LUCY'S TEAROOMS	50 X PINK RIBBON CUPCAKES AND FINGER FOOD FOR 2017 PINK RIBBON WALK	1		1,337.00
INV 1540	15/11/2017	LUCY'S TEAROOMS	CATERING 23/10/2017 SPECIAL COUNCIL MEETING	1	375.00	
INV 1511	06/10/2017	LUCY'S TEAROOMS	CATERING FOR COUNCIL MEETING 13/9/2017.	1	250.00	

Date: 01/12/2017
Time: 9:08:54AM

Shire of Northam

USER: Kathy Scholz
PAGE: 37

Cheque / EFT No	Date	Name	Invoice Description	Bank Code	INV Amount	Amount
INV 1512	06/10/2017	LUCY'S TEAROOMS	CATERING FOR WA REGIONAL CAPITAL ALLIANCE MEETING - 14 SEPTEMBER 2017	1	162.00	
INV 1543	15/11/2017	LUCY'S TEAROOMS	50 X PINK RIBBON CUPCAKES AND FINGER FOOD FOR 2017 PINK RIBBON WALK	1	550.00	
EFT28345	23/11/2017	LUPTONS LIQUID WASTE	CLEAN OUT OF GREASE TRAP FOR KILLARA	1		550.00
INV 50030	20/11/2017	LUPTONS LIQUID WASTE	CLEAN OUT OF GREASE TRAP FOR KILLARA	1	550.00	
EFT28346	23/11/2017	MARK ROBINSON	REIMBURSEMENT FOR PRE-EMPLOYMENT MEDICAL - MARK ROBINSON	1		224.20
INV NPC-504916	11/2017	MARK ROBINSON	POLICE CLEARANCE REIMBURSEMENT.	1	52.60	
INV 111471	09/11/2017	MARK ROBINSON	REIMBURSEMENT FOR PRE-EMPLOYMENT MEDICAL - MARK ROBINSON	1	171.60	
EFT28347	23/11/2017	MOORE STEPHENS (WA) PTY LTD	AVON HEALTH & EMERGENCY SERVICES PRECINCT PROJECT & ROYALTIES FOR REGIONS - AVON RIVER REVITALISATION AND RIVERFRONT DEVELOPMENT.	1		5,915.84
INV 3047140	15/11/2017	MOORE STEPHENS (WA) PTY LTD	PREPARATION FOR AND ATTENDANCE AT AUDIT COMMITTEE MEETING HELD ON 13 NOVEMBER 2017.	1	690.84	
INV 304747	21/11/2017	MOORE STEPHENS (WA) PTY LTD	AVON HEALTH & EMERGENCY SERVICES PRECINCT PROJECT & ROYALTIES FOR REGIONS - AVON RIVER REVITALISATION AND RIVERFRONT DEVELOPMENT.	1	5,225.00	
EFT28348	23/11/2017	NORTH METROPOLITAN TAFE	CERTIFICATE IV IN MARKETING AND COMMUNICATION SEMESTER 2.	1		1,154.15
INV 10003831	15/11/2017	NORTH METROPOLITAN TAFE	CERTIFICATE IV IN MARKETING AND COMMUNICATION SEMESTER 2.	1	1,154.15	
EFT28349	23/11/2017	NORTHAM HOLDEN	27000KM SERVICE TO HOLDEN TRAIL BLAZER PN1618 - N10721	1		355.38
INV 117511	06/11/2017	NORTHAM HOLDEN	EXEC MANAGER ENGINEERING SERVICES. 27000KM SERVICE TO HOLDEN TRAIL BLAZER PN1618 - N10721	1	355.38	
EFT28350	23/11/2017	NORTHAM INDOOR HOCKEY ASSOCIATION	KIDS SPORT FUNDING	1		100.00
INV KS004	13/11/2017	NORTHAM INDOOR HOCKEY ASSOCIATION	KIDS SPORT FUNDING	1	100.00	
EFT28351	23/11/2017	NORTHAM MAZDA	30000KM SERVICE TO MAZDA BT50 PN1516 - N11196	1		295.13
			BUILDING & PROJECTS SUPERVISOR UTE			

Date: 01/12/2017
Time: 9:08:54AM

Shire of Northam

USER: Kathy Scholz
PAGE: 38

Cheque / EFT No	Date	Name	Invoice Description	Bank Code	INV Amount	Amount
INV 116695	08/09/2017	NORTHAM MAZDA	30000KM SERVICE TO MAZDA BT50 PN1516 - NI1196 BUILDING & PROIECTS SUPERVISOR.UTE	1	295.13	
EFT28352	23/11/2017	OLLY'S CAR & FURNITURE UPHOLSTERY'S	REPAIR SHADE SAIL FROM GRASS VALLEY TOWNSITE.	1		330.00
INV 3005	27/10/2017	OLLY'S CAR & FURNITURE UPHOLSTERY'S	REPAIR SHADE SAIL FROM GRASS VALLEY TOWNSITE.	1	330.00	
EFT28353	23/11/2017	OXTER SERVICES	BAKERS HILL TOILETS. 3X CARTONS OF TOILET TISSUE, 1 X DISINFECTANC, 1 X BOX OF VINYL GLOVES.	1		384.56
INV 18861	07/11/2017	OXTER SERVICES	ADMIN BUILDING. SUPPLY 2 X PLASTIC SLIMLINE PAPER TOWEL DISPENSERS.	1	124.52	
INV 18764	17/10/2017	OXTER SERVICES	BAKERS HILL TOILETS. 3X CARTONS OF TOILET TISSUE, 1 X DISINFECTANC, 1 X BOX OF VINYL GLOVES.	1	260.04	
EFT28354	23/11/2017	PRESTIGE ALARMS	ADMIN BUILDING. ATTENDS SITE AND REPAIR TITAN SOFTWARE.	1		549.50
INV 0000191709/11/2017		PRESTIGE ALARMS	NORTHAM SHIRE ADMIN BUILDING. 24 HOUR MONITORING OF SECURITY ALARM SYSTEM. QUARTERLY ACCOUNT 01/12/2017 TO 28/02/2018.	1	115.00	
INV 0009481117/11/2017		PRESTIGE ALARMS	ADMIN BUILDING. ATTENDS SITE AND REPAIR TITAN SOFTWARE.	1	434.50	
EFT28355	23/11/2017	RURAL PRESS REGIONAL MEDIA (WA) PTY LTD	QUARTERLY REPORT - SEPTEMBER 2017	1		3,394.82
INV 5267691	25/10/2017	RURAL PRESS REGIONAL MEDIA (WA) PTY LTD	QUARTERLY REPORT - SEPTEMBER 2017	1	997.57	
INV 5257215	04/10/2017	RURAL PRESS REGIONAL MEDIA (WA) PTY LTD	ADVERT IN THE AVON VALLEY ADVOCATE ON 4TH AND 11TH OCTOBER FOR THE DRAFT NORTHAM TOWN CENTRE DEVELOPMENT AND CONNECTIVITY STRATEGY	1	436.59	
INV 5258275	04/10/2017	RURAL PRESS REGIONAL MEDIA (WA) PTY LTD	EMPLOYMENT ADVERT IN THE AVON VALLEY ADVOCATE - 4/10/2017	1	526.50	
INV 5257215	11/10/2017	RURAL PRESS REGIONAL MEDIA (WA) PTY LTD	ADVERT IN THE AVON VALLEY ADVOCATE ON 4TH AND 11TH OCTOBER FOR THE DRAFT NORTHAM TOWN CENTRE DEVELOPMENT AND CONNECTIVITY STRATEGY	1	436.59	
INV 5267688825/10/2017		RURAL PRESS REGIONAL MEDIA (WA) PTY LTD	MONTHLY NEWSLETTER FULL PAGE AD	1	997.57	
EFT28356	23/11/2017	SIGMA CHEMICALS	COMMERCIAL PICTO ALUMIN STENCIL KIT	1		203.50

Date: 01/12/2017
Time: 9:08:54AM

Shire of Northam

USER: Kathy Scholz
PAGE: 39

Cheque / EFT No	Date	Name	Invoice Description	Bank Code	INV Amount	Amount
INV 108712025/10/2017		SIGMA CHEMICALS	COMMERCIAL PICTO ALUMIN STENCIL KIT	1	203.50	
EFT28357	23/11/2017	SPECIALISED TREE SERVICE	GRASS VALLEY SOUTH ROAD CLEAN UP AFTER STORM DAMAGE AND REMOVE HANGER FROM TREE	1		1,260.00
INV 2666	09/11/2017	SPECIALISED TREE SERVICE	GRASS VALLEY SOUTH ROAD CLEAN UP AFTER STORM DAMAGE AND REMOVE HANGER FROM TREE	1	1,260.00	
EFT28358	23/11/2017	THE WORKWEAR GROUP	UNIFORM FOR JENNY BECKER	1		245.65
INV 0302835209/11/2017		THE WORKWEAR GROUP	UNIFORM FOR JENNY BECKER	1	245.65	
EFT28359	23/11/2017	TREVOR EASTWELL	DRIVER FOR NIGHT HOOPS ON 21ST & 28TH OCTOBER 2017.	1		240.00
INV RR2111221/11/2017		TREVOR EASTWELL	DRIVER FOR NIGHT HOOPS ON 21ST & 28TH OCTOBER 2017.	1	240.00	
EFT28360	23/11/2017	VINCELEC	REPLACE FAN FORCE ELEMENT TO OVEN IN KILLARA COTTAGE	1		165.00
INV 423	08/11/2017	VINCELEC	REPLACE FAN FORCE ELEMENT TO OVEN IN KILLARA COTTAGE	1	165.00	
EFT28361	23/11/2017	WA HINO SALES & SERVICES	5,000KM FIRST SERVICE TO PN1612	1		380.30
INV HTCS11107/11/2017		WA HINO SALES & SERVICES	5,000KM FIRST SERVICE TO PN1612	1	380.30	
EFT28362	23/11/2017	WARRICKS NEWSAGENCY	STATIONERY FOR SHIRE ADMIN.	1		1,230.86
INV SN0000601/11/2017		WARRICKS NEWSAGENCY	NEWSPAPERS FOR OCTOBER 2017 FOR ADMIN.	1	75.80	
INV SN00017301/11/2017		WARRICKS NEWSAGENCY	COPIES OF NEWSPAPERS FOR KILLARA - OCTOBER 2017.	1	39.40	
INV SN00017301/11/2017		WARRICKS NEWSAGENCY	NEWSPAPERS & MAGAZINES FOR LIBRARY OCTOBER 2017.	1	140.82	
INV 48059	10/11/2017	WARRICKS NEWSAGENCY	STATIONERY FOR ADMIN.	1	445.96	
INV 47760	22/10/2017	WARRICKS NEWSAGENCY	STATIONERY FOR SHIRE ADMIN.	1	528.88	
EFT28363	23/11/2017	WESTWIDE AUTO ELECTRICS AND AIR CONDITIONING	PN1003 - REVERSE BEEPER NOT WORKING, NO HEADLIGHTS AND ONE BEACON NOT WORKING	1		696.00
INV 7293	09/10/2017	WESTWIDE AUTO ELECTRICS AND AIR CONDITIONING	PN1003 - REVERSE BEEPER NOT WORKING, NO HEADLIGHTS AND ONE BEACON NOT WORKING	1	696.00	
EFT28364	23/11/2017	WHEATBELT OFFICE & BUSINESS MACHINES	TONER CARTRIDGES FOR PRINTERS.	1		979.20

Date: 01/12/2017
Time: 9:08:54AM

Shire of Northam

USER: Kathy Scholz
PAGE: 40

Cheque / EFT No	Date	Name	Invoice Description	Bank Code	INV Amount	Amount
INV 22720	17/11/2017	WHEATBELT OFFICE & BUSINESS MACHINES	TONER CARTRIDGES FOR PRINTERS.	1	979.20	
EFT28365	29/11/2017	ROBERT LESLIE HITCHCOCK	REPLACEMENT OF DAMAGED GATE.	1		166.65
INV 230579	16/11/2017	ROBERT LESLIE HITCHCOCK	REPLACEMENT OF DAMAGED GATE.	1	166.65	
EFT28366	29/11/2017	WESTERN AUSTRALIAN TREASURY CORPORATION	Loan No. 221 Interest payment - AIRSTRIP UPGRADE	1		6,951.22
INV 221	29/11/2017	WESTERN AUSTRALIAN TREASURY CORPORATION	Loan No. 221 Interest payment - AIRSTRIP UPGRADE		6,951.22	
EFT28367	30/11/2017	SPECIALISED TREE SERVICE	PRUNE NORTHAM TOWNSITE STREET TREES AS PER CONTRACT 19 OF 2015	1		7,602.00
INV 2665	09/11/2017	SPECIALISED TREE SERVICE	REMOVE OVERHANGING LIMB AT 13 QUELQUELLING ROAD	1	420.00	
INV 2680	17/11/2017	SPECIALISED TREE SERVICE	PRUNE NORTHAM TOWNSITE STREET TREES AS PER CONTRACT 19 OF 2015	1	7,182.00	
EFT28368	30/11/2017	WCP CIVIL PTY LTD	CARLIN VALLEY DRAINAGE IMPROVEMENTS - IMPROVEMENT WORKS PROGRESS CLAIM 2 CONTRACT 6 OF 2016.	1		22,837.84
INV 600802	14/09/2017	WCP CIVIL PTY LTD	CARLIN VALLEY DRAINAGE IMPROVEMENTS - IMPROVEMENT WORKS PROGRESS CLAIM 2 CONTRACT 6 OF 2016.	1	22,837.84	
EFT28369	30/11/2017	AGENCY HOLDINGS PTY LTD T/AS COOPER ENGRAVING	ADMIN BUILDING. ENGRAVING FOR COUNCIL HONOUR BOARD.	1		371.31
INV 102524	23/11/2017	AGENCY HOLDINGS PTY LTD T/AS COOPER ENGRAVING	ADMIN BUILDING. ENGRAVING FOR COUNCIL HONOUR BOARD.	1	371.31	
EFT28370	30/11/2017	ALL-WAYS FOODS	STOCK PURCHASES FOR NORTHAM POOL.	1		862.86
INV 33812	25/10/2017	ALL-WAYS FOODS	STOCK PURCHASES FOR NORTHAM POOL.	1	862.86	
EFT28371	30/11/2017	APPLIED INDUSTRIAL TECHNOLOGIES T/A NORTHAM BEARINGS	WIRE ROPE, FERRULE COPPER, DEE SHACKLE GALVANISED & BOW SHACKLE FOR NORTHAM AERO CLUB TO INSTALL WINDSOCK.	1		108.78

Date: 01/12/2017
Time: 9:08:54AM

Shire of Northam

USER: Kathy Scholz
PAGE: 41

Cheque / EFT No	Date	Name	Invoice Description	Bank Code	INV Amount	Amount
INV 6016098	30/10/2017	APPLIED INDUSTRIAL TECHNOLOGIES T/A NORTHAM BEARINGS	WIRE ROPE, FERRULE COPPER, D SHACKLE GALVANISED & BOW SHACKLE FOR NORTHAM AERO CLUB TO INSTALL WINDSOCK.	1	55.43	
INV 6014371	26/10/2017	APPLIED INDUSTRIAL TECHNOLOGIES T/A NORTHAM BEARINGS	BARE CO COTTER BOLT (B3728)	1	53.35	
EFT28372	30/11/2017	AUSTRALIAN SERVICES UNION	Payroll deductions	1		27.45
INV DEDUCT28/11/2017		AUSTRALIAN SERVICES UNION	Payroll deductions		27.45	
EFT28373	30/11/2017	AUSTRALIAN TAXATION OFFICE - PAYG	PAYG PAY RUN WEEK END 28/11/2017 & INTERIM PAY 22/11/2017.	1		55,872.00
INV PAYG 2828/11/2017		AUSTRALIAN TAXATION OFFICE - PAYG	PAYG PAY RUN WEEK END 28/11/2017 & INTERIM PAY 22/11/2017.	1	55,872.00	
EFT28374	30/11/2017	AUTOPRO NORTHAM	EMPLOYEE OF THE QUARTER GIFT VOUCHER -	1		250.00
INV 696612	01/11/2017	AUTOPRO NORTHAM	EMPLOYEE OF THE QUARTER GIFT VOUCHER -	1	250.00	
EFT28375	30/11/2017	AVON DEMOLITION & EARTHMOVING	MANAGEMENT OF INKPEN ROAD WASTE MANAGEMENT FACILITY: 7/11/2017 TO 19/11/2017.	1		1,568.00
INV 0067	19/11/2017	AVON DEMOLITION & EARTHMOVING	MANAGEMENT OF INKPEN ROAD WASTE MANAGEMENT FACILITY: 7/11/2017 TO 19/11/2017.	1	1,568.00	
EFT28376	30/11/2017	AVON TOURISM INCORPORATED	1/3 PAGE AD IN EXPERIENCE PERTH 2018 HOLIDAY PLANNER	1		1,350.00
INV 2018 EPH15/11/2017		AVON TOURISM INCORPORATED	1/3 PAGE AD IN EXPERIENCE PERTH 2018 HOLIDAY PLANNER	1	1,350.00	
EFT28377	30/11/2017	AVON VALLEY CONTRACTORS	HIRE OF DINGO WITH TRENCHER	1		320.00
INV 2049	09/11/2017	AVON VALLEY CONTRACTORS	HIRE OF DINGO WITH TRENCHER	1	320.00	
EFT28378	30/11/2017	AVON WASTE	DOMESTIC & COMMERCIAL RUBBISH COLLECTION IN THE SHIRE OF NORTHAM FOR THE FORTNIGHT ENDING 27/10/2017.	1		83,514.35
INV 26737	27/10/2017	AVON WASTE	DOMESTIC & COMMERCIAL RUBBISH COLLECTION IN THE SHIRE OF NORTHAM FOR THE FORTNIGHT ENDING 27/10/2017.	1	83,514.35	
EFT28379	30/11/2017	BROOKE EVANS	STATIONERY FOR COUNTRY COPIERS.	1		22.40
INV RR2711207/11/2017		BROOKE EVANS	STATIONERY FOR COUNTRY COPIERS.	1	22.40	

Date: 01/12/2017
Time: 9:08:54AM

Shire of Northam

USER: Kathy Scholz
PAGE: 42

Cheque / EFT No	Date	Name	Invoice Description	Bank Code	INV Amount	Amount
EFT28380	30/11/2017	BURGESS RAWSON (WA) PTY LTD	WATER & SEWERAGE RATES FOR DUMP POINT ON PEEL TCE FOR THE PERIOD 12/09/2017 TO 31/12/2017.	1		49.06
INV 485446	15/11/2017	BURGESS RAWSON (WA) PTY LTD	WATER & SEWERAGE RATES FOR DUMP POINT ON PEEL TCE FOR THE PERIOD 12/09/2017 TO 31/12/2017.	1	49.06	
EFT28381	30/11/2017	CHAS CLARKSON	100MM UV STABLE BAUBLE	1		465.00
INV INV2343915/11/2017		CHAS CLARKSON	100MM UV STABLE BAUBLE	1	465.00	
EFT28382	30/11/2017	COCA-COLA AMATIL (AUST) PTY LTD	STOCK PURCHASES FOR NORTHAM POOL.	1		1,923.74
INV 2161717208/11/2017		COCA-COLA AMATIL (AUST) PTY LTD	STOCK PURCHASES NORTHAM POOL.	1	449.14	
INV 2160659725/10/2017		COCA-COLA AMATIL (AUST) PTY LTD	STOCK PURCHASES FOR NORTHAM POOL.	1	1,474.60	
EFT28383	30/11/2017	COURIER AUSTRALIA	FREIGHT CHARGES FOR DEVELOPMENT SERVICES & LIBRARY.	1		486.17
INV 0330	17/11/2017	COURIER AUSTRALIA	COURIER DELIVERY CHARGES FOR ENGINEERING SERVICES FOR THE PERIOD 12/11/2017 TO 16/11/2017.	1	116.72	
INV 0328	03/11/2017	COURIER AUSTRALIA	FREIGHT CHARGES FOR DEVELOPMENT SERVICES & LIBRARY.	1	150.89	
INV 0327	27/10/2017	COURIER AUSTRALIA	FREIGHT CHARGES FOR DEVELOPMENT SERVICES, LIBRARY & ADMIN.	1	148.58	
INV 0329	10/11/2017	COURIER AUSTRALIA	FREIGHT CHARGES FOR DEVELOPMENT SERVICES AND DEPOT.	1	69.98	
EFT28384	30/11/2017	DANIELS HEALTH SERVICES PTY LTD	JUBILEE PAVILION TOILETS - SERVICING OF SHARPS SAFES OCTOBER 2017.	1		732.11
INV 1604074	31/10/2017	DANIELS HEALTH SERVICES PTY LTD	JUBILEE PAVILION TOILETS - SERVICING OF SHARPS SAFES OCTOBER 2017.	1	172.26	
INV 1604071	31/10/2017	DANIELS HEALTH SERVICES PTY LTD	BERNARD PARK PUBLIC TOILETS - SERVICING OF SHARPS SAFES OCTOBER 2017.	1	129.20	
INV 1604070	31/10/2017	DANIELS HEALTH SERVICES PTY LTD	BAKERS HILL PUBLIC TOILETS - SERVICING OF SHARPS SAFES OCTOBER 2017.	1	172.26	
INV 1604072	31/10/2017	DANIELS HEALTH SERVICES PTY LTD	APEX PARK PUBLIC TOILETS - SERVICING OF SHARPS SAFES OCTOBER 2017.	1	172.26	
INV 1604073	31/10/2017	DANIELS HEALTH SERVICES PTY LTD	WUNDOWIE PUBLIC TOILETS - SERVICING OF SHARPS SAFES OCTOBER 2017.	1	86.13	
EFT28385	30/11/2017	EASIFLEET	Payroll deductions	1		2,113.47

Date: 01/12/2017
Time: 9:08:54AM

Shire of Northam

USER: Kathy Scholz
PAGE: 43

Cheque / EFT No	Date	Name	Invoice Description	Bank Code	INV Amount	Amount
INV DEDUCT28/11/2017		EASIFLEET	Payroll deductions		1,238.30	
INV DEDUCT28/11/2017		EASIFLEET	Payroll deductions		875.17	
EFT28386	30/11/2017	ELDERS LIMITED	4 X 20LT GLYPHOSATE FOR PARKS & GARDENS.	1		396.00
INV AX48962.30/10/2017		ELDERS LIMITED	4 X 20LT GLYPHOSATE FOR PARKS & GARDENS.	1	396.00	
EFT28387	30/11/2017	FRONTLINE FIRE & RESCUE EQUIPMENT	EQUIPMENT FOR FIRE BRIGADES	1		811.97
INV 58313	27/10/2017	FRONTLINE FIRE & RESCUE EQUIPMENT	EQUIPMENT FOR FIRE BRIGADES	1	811.97	
EFT28388	30/11/2017	GEORGE PAUL	CROSSOVER REBATE PAYMENT FOR 20 OAKOVER PLACE NORTHAM	1		600.00
INV 172627	23/11/2017	GEORGE PAUL	CROSSOVER REBATE PAYMENT FOR 20 OAKOVER PLACE NORTHAM	1	600.00	
EFT28389	30/11/2017	HAYS SPECIALIST RECRUITMENT (AUSTRALIA) PTY LIMITED	LABOUR HIRE WORKS SUPERVISOR GEOFFREY COPLEY FOR WEEK ENDING 05/11/2017.	1		17,318.97
INV 6920532	11/10/2017	HAYS SPECIALIST RECRUITMENT (AUSTRALIA) PTY LIMITED	LABOUR HIRE FOR ADRIAN MUNCKTON FOR THE WEEK ENDING 08/10/2017.	1	1,384.09	
INV 7002192	15/11/2017	HAYS SPECIALIST RECRUITMENT (AUSTRALIA) PTY LIMITED	LABOUR HIRE WORKS SUPERVISOR GEOFFREY COPLEY FOR WEEK ENDING 05/11/2017.	1	3,017.27	
INV 6920531	11/10/2017	HAYS SPECIALIST RECRUITMENT (AUSTRALIA) PTY LIMITED	LABOUR HIRE FOR MARK SCHNELL FOR THE WEEK ENDING 08/10/2017.	1	1,735.27	
INV 6952732	25/10/2017	HAYS SPECIALIST RECRUITMENT (AUSTRALIA) PTY LIMITED	LABOUR HIRE FOR ADRIAN MUNCKTON FOR THE WEEK ENDING 22/10/2017.	1	1,053.56	
INV 6936558	18/10/2017	HAYS SPECIALIST RECRUITMENT (AUSTRALIA) PTY LIMITED	LABOUR HIRE FOR ADRIAN MUNCKTON FOR THE WEEK ENDING 15/10/2017.	1	1,755.93	
INV 7002193	15/11/2017	HAYS SPECIALIST RECRUITMENT (AUSTRALIA) PTY LIMITED	LABOUR HIRE WORKS SUPERVISOR GEOFFREY COPLEY FOR WEEK ENDING 12/11/2017.	1	2,455.92	
INV 6969797	01/11/2017	HAYS SPECIALIST RECRUITMENT (AUSTRALIA) PTY LIMITED	LABOUR HIRE WORKS SUPERVISOR GEOFFREY COPLEY FOR WEEK ENDING 29/10/2017.	1	2,491.01	
INV 7002191	15/11/2017	HAYS SPECIALIST RECRUITMENT (AUSTRALIA) PTY LIMITED	LABOUR HIRE FOR ADRIAN MUNCKTON FOR THE WEEK ENDING 12/11/2017.	1	616.44	
INV 6986013	08/11/2017	HAYS SPECIALIST RECRUITMENT (AUSTRALIA) PTY LIMITED	LABOUR HIRE FOR ADRIAN MUNCKTON FOR THE WEEK ENDING 05/11/2017.	1	1,404.74	
INV 6969796	01/11/2017	HAYS SPECIALIST RECRUITMENT (AUSTRALIA) PTY LIMITED	LABOUR HIRE FOR ADRIAN MUNCKTON FOR THE WEEK ENDING 29/10/2017.	1	1,404.74	
EFT28390	30/11/2017	HOST AUTO REPAIRS	REPAIRS TO FIRE TRUCK 1BNP584.	1		3,915.30

Date: 01/12/2017
Time: 9:08:54AM

Shire of Northam

USER: Kathy Scholz
PAGE: 44

Cheque / EFT No	Date	Name	Invoice Description	Bank Code	INV Amount	Amount
INV 61139	15/11/2017	HOST AUTO REPAIRS	REPAIRS TO FIRE TRUCK 1BNP584.	1	2,686.40	
INV 61143	10/11/2017	HOST AUTO REPAIRS	ANNUAL SERVICE OF FIRE TRUCK N3113/INKPEN 2.4.	1	606.55	
INV 61137	31/10/2017	HOST AUTO REPAIRS	ANNUAL SERVICE FIRE TRUCK - 1BNP584 BAKERS HILL 2.4.	1	622.35	
EFT28391	30/11/2017	IXOM OPERATIONS PTY LTD	920KG CHLORINE GAS FOR NORTHAM SWIMMING POOL.	1		2,824.80
INV 5883388	16/10/2017	IXOM OPERATIONS PTY LTD	920KG CHLORINE GAS FOR NORTHAM SWIMMING POOL.	1	2,824.80	
EFT28392	30/11/2017	JS TECHNOLOGY & DIGITAL PTY LTD	IPHONE 7 CASES & SCREEN PROTECTORS.	1		205.00
INV 2463	21/11/2017	JS TECHNOLOGY & DIGITAL PTY LTD	IPHONE 7 CASES & SCREEN PROTECTORS.	1	205.00	
EFT28393	30/11/2017	JTAGZ PTY LTD	DOG TAGS.	1		137.50
INV 0000654821/11/2017		JTAGZ PTY LTD	DOG TAGS.	1	137.50	
EFT28394	30/11/2017	KEN BLACKHURST	YOUTH SUPPORT AT NIGHT HOOPS PROGRAM 4 X \$120.00 14/10/2017 TO 18/11/2017.	1		480.00
INV RR28112028/11/2017		KEN BLACKHURST	YOUTH SUPPORT AT NIGHT HOOPS PROGRAM 4 X \$120.00 14/10/2017 TO 18/11/2017.	1	480.00	
EFT28395	30/11/2017	KERBTECH P/L T/A GDR CIVIL CONTRACTING	HIRE OF SMALL EXCAVATOR FOR 3 DAYS AT MITCHELL AVENUE.	1		924.00
INV 1225	19/09/2017	KERBTECH P/L T/A GDR CIVIL CONTRACTING	HIRE OF SMALL EXCAVATOR FOR 3 DAYS AT MITCHELL AVENUE.	1	924.00	
EFT28396	30/11/2017	KLEENWEST DISTRIBUTORS	ASSORTED CHEMICALS & ITEMS FOR KILLARA	1		393.14
INV 0002756624/10/2017		KLEENWEST DISTRIBUTORS	ASSORTED CHEMICALS & ITEMS FOR KILLARA	1	393.14	
EFT28397	30/11/2017	KOMATSU AUSTRALIA PTY LTD	FRONT GLASS PANEL ON KOMATSU LOADER WA 250PZ - 6 WHEEL LOADER	1		785.00
INV 0008398720/11/2017		KOMATSU AUSTRALIA PTY LTD	FRONT GLASS PANEL ON KOMATSU LOADER WA 250PZ - 6 WHEEL LOADER	1	785.00	
EFT28398	30/11/2017	LANDGATE	SLIP SUBSCRIPTION SERVICES AND LAND PACKAGES - SMALL	1		3,143.72
INV 334932-1027/10/2017		LANDGATE	RURAL UV INTERIM VALUATION SHARED.	1	242.70	
INV 334871-1026/10/2017		LANDGATE	GROSS RENTAL VALUATIONS CHARGEABLE SCHEDULE NO G 2017/11 DATED 23/09/2017 TO 20/10/2017.	1	336.42	

Date: 01/12/2017
Time: 9:08:54AM

Shire of Northam

USER: Kathy Scholz
PAGE: 45

Cheque / EFT No	Date	Name	Invoice Description	Bank Code	INV Amount	Amount
INV 802831	02/11/2017	LANDGATE	LAND ENQUIRY	1	50.60	
INV 6225720602	11/2017	LANDGATE	SLIP SUBSCRIPTION SERVICES AND LAND PACKAGES - SMALL	1	2,514.00	
EFT28399	30/11/2017	LANDMARK	20L DRUM OF BASTA	1		893.64
INV 9991166901	11/2017	LANDMARK	20L DRUM OF BASTA	1	893.64	
EFT28400	30/11/2017	LANDMARK ENGINEERING & DESIGN T/A EXTERIA	MANUFACTURE, SUPPLY & DELIVER 1 X GARDENS TABLE WHEELCHAIR COMPLIANT & 2 X BOARDWALK BENCHES WHEELCHAIR COMPLIANT.	1		4,359.30
INV 0000722615	11/2017	LANDMARK ENGINEERING & DESIGN T/A EXTERIA	MANUFACTURE, SUPPLY & DELIVER 1 X GARDENS TABLE WHEELCHAIR COMPLIANT & 2 X BOARDWALK BENCHES WHEELCHAIR COMPLIANT.	1	4,359.30	
EFT28401	30/11/2017	LED SIGNS	REPAIRED ANTENNA SOCKET CLEANED BUTTONS SHOWED CORRECT OPERATION OF CONTROLLERS AND PROVIDED A MANUAL.	1		667.70
INV 17165	13/11/2017	LED SIGNS	REPAIRED ANTENNA SOCKET CLEANED BUTTONS SHOWED CORRECT OPERATION OF CONTROLLERS AND PROVIDED A MANUAL.	1	667.70	
EFT28402	30/11/2017	LOCAL GOVERNMENT AND RACECOURSE EMPLOYEES UNION	Payroll deductions	1		20.50
INV DEDUCT28	11/2017	LOCAL GOVERNMENT AND RACECOURSE EMPLOYEES UNION	Payroll deductions		20.50	
EFT28403	30/11/2017	MARKETFORCE	ADVERTISING ON SEEK FOR SUPPORT WORKER, ENGINEERING SERVICES TRAINEE AND ASSET / DESIGN COORDINATOR AND COMBINED AD IN THE HILLS GAZETTE ON 6/10/2017	1		5,946.85
INV 17525	25/10/2017	MARKETFORCE	ADVERT FOR SPECIAL COUNCIL MEETING ON 23/10/2017 IN THE WEST AUSTRALIAN ON 21/10/2017	1	436.52	
INV 17520	25/10/2017	MARKETFORCE	ADVERTISING ON SEEK FOR SUPPORT WORKER, ENGINEERING SERVICES TRAINEE AND ASSET / DESIGN COORDINATOR AND COMBINED AD IN THE HILLS GAZETTE ON 6/10/2017	1	1,539.54	
INV 17522	25/10/2017	MARKETFORCE	EMPLOYMENT ADVERT - TECHNICAL OFFICER, SEEK, WEST HILLS GAZETTE 20/10/2017, ADVOCATE 25/10/2017	1	1,055.84	
INV 17524	25/10/2017	MARKETFORCE	EMPLOYMENT ADVERT - PROJECT DEVELOPMENT ENGINEER - WEST AUSTRALIAN 18/10/2017	1	791.12	

Date: 01/12/2017
Time: 9:08:54AM

Shire of Northam

USER: Kathy Scholz
PAGE: 46

Cheque / EFT No	Date	Name	Invoice Description	Bank Code	INV Amount	Amount
INV 17523	25/10/2017	MARKETFORCE	EMPLOYMENT ADVERT - COMPLIANCE OFFICER, SEEK HILLS GAZETTE 25/10/2017. ADVOCATE 25/10/2017	1	1,321.10	
INV 17521	25/10/2017	MARKETFORCE	EMPLOYMENT ADVERT - PROJECT DEVELOPMENT ENGINEER - WEST AUSTRALIAN 18/10/2017	1	802.73	
EFT28404	30/11/2017	MATHEW MACQUEEN	FIRE BREAK/PROPERTY INSPECTIONS FOR THE 2017/18 FIRE SEASON	1		1,760.00
INV 640	19/11/2017	MATHEW MACQUEEN	FIRE BREAK/PROPERTY INSPECTIONS FOR THE 2017/18 FIRE SEASON	1	1,760.00	
EFT28405	30/11/2017	MORTLOCK TIMBER GROUP	SUSPENSION BRIDGE. SUPPLY JARRAH BOARDS TO REPLACE DAMAGED ONES, AS PER QUOTE 11152.	1		639.60
INV 11124	01/11/2017	MORTLOCK TIMBER GROUP	SUSPENSION BRIDGE, SUPPLY JARRAH BOARDS TO REPLACE DAMAGED ONES, AS PER QUOTE 11152.	1	639.60	
EFT28406	30/11/2017	NORTHAM & DISTRICTS GLASS SERVICE	INSTALL INVISI GARD SECURITY FLYSCREENS AT SOUTHERN BROOK, IRISHTOWN & CLACKLINE BFB.	1		3,239.50
INV 0000432	17/11/2017	NORTHAM & DISTRICTS GLASS SERVICE	INSTALL INVISI GARD SECURITY FLYSCREENS AT SOUTHERN BROOK, IRISHTOWN & CLACKLINE BFB.	1	3,239.50	
EFT28407	30/11/2017	NORTHAM AND DISTRICTS GUN CLUB	SENIOR SPORT FUNDING	1		150.00
INV 0039	29/11/2017	NORTHAM AND DISTRICTS GUN CLUB	SENIOR SPORT FUNDING	1	150.00	
EFT28408	30/11/2017	NORTHAM FEED & HIRE	DOG & CAT FOOD AND OTHER MISCELLANEOUS ITEMS - NOVEMBER 2017.	1		22.00
INV 0000093210/11/2017		NORTHAM FEED & HIRE	DOG & CAT FOOD AND OTHER MISCELLANEOUS ITEMS - NOVEMBER 2017.	1	22.00	
EFT28409	30/11/2017	NORTHAM FLORIST	FRUIT BASKET / DELIVERY FOR KOBUS NIEUWOUDT	1		115.00
INV 18931	20/11/2017	NORTHAM FLORIST	FRUIT BASKET / DELIVERY FOR KOBUS NIEUWOUDT	1	115.00	
EFT28410	30/11/2017	NORTHAM HARDWARE	4 X SAFETY LIGHTS FOR EVENTS STAFF	1		249.67
INV 353569	19/10/2017	NORTHAM HARDWARE	ELECTRICAL TAPE, CONNECTOR STRIP 6 TERMINAL & WIRE CONNECTORS FOR BERNARD PARK RETIC.	1	21.35	
INV 354052	26/10/2017	NORTHAM HARDWARE	4 X SAFETY LIGHTS FOR EVENTS STAFF & BATTERIES	1	10.20	
INV 354051	26/10/2017	NORTHAM HARDWARE	4 X SAFETY LIGHTS FOR EVENTS STAFF	1	131.80	
INV 353473	17/10/2017	NORTHAM HARDWARE	2 X TUBE OF APOXY RESIN 4 WAY CHUCK KEY	1	37.00	

Date: 01/12/2017
Time: 9:08:54AM

Shire of Northam

USER: Kathy Scholz
PAGE: 47

Cheque / EFT No	Date	Name	Invoice Description	Bank Code	INV Amount	Amount
INV 354074	26/10/2017	NORTHAM HARDWARE	PARTS FOR THE WATER PLAYGROUND (BERNARD PARK)	1	49.32	
EFT28411	30/11/2017	NORTHAM LIQUOR BARONS	STOCK FOR COUNCIL CHAMBERS	1		560.84
INV 120319	22/11/2017	NORTHAM LIQUOR BARONS	STOCK FOR COUNCIL CHAMBERS	1	560.84	
EFT28412	30/11/2017	NORTHAM MITRE 10 SOLUTIONS	RAPID SET CONCRETE FOR ASSORTED ROAD WORKS.	1		779.93
INV 1023181227/10/2017	10/2017	NORTHAM MITRE 10 SOLUTIONS	NUT HEXAGON & BOLTS FOR CHRISTMAS DECORATIONS.	1	12.47	
INV 1023175827/10/2017	10/2017	NORTHAM MITRE 10 SOLUTIONS	BOLT & NUT HEX GALVANISED FOR NORTHAM AERO CLUB WINDSOCK INSTALLATION.	1	13.21	
INV 1023175627/10/2017	10/2017	NORTHAM MITRE 10 SOLUTIONS	CHAIN LINKS, SHACKLES & INDUSTRIAL BOLT CUTTER FOR NORTHAM AERO CLUB WINDSOCK INSTALLATION.	1	69.17	
INV 1023140326/10/2017	10/2017	NORTHAM MITRE 10 SOLUTIONS	RAPID SET CONCRETE FOR ASSORTED ROAD WORKS.	1	405.00	
INV 1023215328/10/2017	10/2017	NORTHAM MITRE 10 SOLUTIONS	BARREL UNION & PRESSURE GAUGE FOR BERNARD PARK RETIC.	1	45.14	
INV 1023149026/10/2017	10/2017	NORTHAM MITRE 10 SOLUTIONS	PARTS FOR WATER PLAYGROUND	1	116.66	
INV 1023046823/10/2017	10/2017	NORTHAM MITRE 10 SOLUTIONS	POWERBOARDS FOR NORTHAM DEPOT	1	118.28	
EFT28413	30/11/2017	NORTHAM SWIMMING CLUB	KIDSPORT FUNDING	1		200.00
INV 0002	20/11/2017	NORTHAM SWIMMING CLUB	KIDSPORT FUNDING	1	200.00	
EFT28414	30/11/2017	NORTHAM TOWING SERVICE	REMOVAL OF ABANDONED VEHICLE - BLUE HATCHBACK FROM BANKSIA AVE. WUNDOWIE, JUST PAST LESCHENAULTIA	1		661.65
INV 206324	12/10/2017	NORTHAM TOWING SERVICE	REMOVE ABANDONED WHITE MAZDA FROM LYON STREET, CROSSROAD BYFIELD STREET.	1	88.00	
INV 206346	21/10/2017	NORTHAM TOWING SERVICE	TOWING OF BURNT OUT VEHICLE FROM WESTERN POWER	1	132.00	
INV 206347	21/10/2017	NORTHAM TOWING SERVICE	TOWING OF VEHICLE FROM OUTSIDE 82	1	153.45	
INV 206384	30/10/2017	NORTHAM TOWING SERVICE	REMOVAL OF ABANDONED VEHICLE - WHITE STATION SEDAN (REGO: 9IU 964) FROM 4 FORWARD ST. NORTHAM	1	88.00	
INV 206376	28/10/2017	NORTHAM TOWING SERVICE	REMOVAL OF ABANDONED VEHICLE - BLUE HATCHBACK FROM BANKSIA AVE. WUNDOWIE, JUST PAST LESCHENAULTIA	1	200.20	
EFT28415	30/11/2017	OFFICEWORKS SUPERSTORES PTY LTD	CHAIRS FOR SES MEETING ROOMS.	1		2,074.95

Date: 01/12/2017
Time: 9:08:54AM

Shire of Northam

USER: Kathy Scholz
PAGE: 48

Cheque / EFT No	Date	Name	Invoice Description	Bank Code	INV Amount	Amount
INV 3706064027/10/2017		OFFICEWORKS SUPERSTORES PTY LTD	CHAIRS FOR SES MEETING ROOMS.	1	2,074.95	
EFT28416	30/11/2017	OXTER SERVICES	HAND TOWELS, TOILET PAPER FOR VARIOUS SHIRE BUILDINGS.	1		1,530.53
INV 18933	20/11/2017	OXTER SERVICES	HAND TOWELS, TOILET PAPER FOR VARIOUS SHIRE BUILDINGS.	1	804.53	
INV 18925	17/11/2017	OXTER SERVICES	GRAVE REOPENING FOR THE BURIAL OF AGNES CROOKS EVELYN WILLIS 13/11/2017.	1	726.00	
EFT28417	30/11/2017	PERTH ENERGY PTY LTD	ELECTRICITY CHARGES - 182 FITZGERALD STREET STATEMENT NO: 2136327 & ACCOUNT NO:601148.	1		242.53
INV 2136327	15/11/2017	PERTH ENERGY PTY LTD	ELECTRICITY CHARGES - 182 FITZGERALD STREET STATEMENT NO: 2136327 & ACCOUNT NO:601148.	1	242.53	
EFT28418	30/11/2017	PFD FOOD SERVICES PTY LTD	STOCK PURCHASES FOR NORTHAM SWIMMING POOL.	1		2,401.95
INV KH7564325/10/2017		PFD FOOD SERVICES PTY LTD	STOCK PURCHASES FOR NORTHAM SWIMMING POOL.	1	1,199.70	
INV K121864/17/11/2017		PFD FOOD SERVICES PTY LTD	STOCK PURCHASES FOR NORTHAM POOL.	1	716.05	
INV KH9076208/11/2017		PFD FOOD SERVICES PTY LTD	STOCK PURCHASES FOR NORTHAM POOL.	1	486.20	
EFT28419	30/11/2017	PRIMARIES OF WA PTY LTD	BAGS FOR ECO RED FERTILIZER	1		2,046.56
INV 2520020003/11/2017		PRIMARIES OF WA PTY LTD	BAGS FOR ECO RED FERTILIZER	1	1,462.16	
INV 2520010013/11/2017		PRIMARIES OF WA PTY LTD	FENCING STRAINERS FOR ROAD MAINTENANCE.	1	584.40	
EFT28420	30/11/2017	REGIONAL PHYSIOTHERAPY & SPORTS INJURY CLINIC & IN BALANCE FITNESS	SENIOR SPORT FUNDING	1		300.00
INV 0013334	14/11/2017	REGIONAL PHYSIOTHERAPY & SPORTS INJURY CLINIC & IN BALANCE FITNESS	SENIOR SPORT FUNDING	1	150.00	
INV 0011736	04/10/2017	REGIONAL PHYSIOTHERAPY & SPORTS INJURY CLINIC & IN BALANCE FITNESS	SENIOR SPORT FUNDING	1	150.00	
EFT28421	30/11/2017	ROADS2000	1.5 T OF 7MM RED LATERITE 2% RED OXIDE TO BE PICKED UP 21 NOVEMBER 2017	1		414.69
INV 18973	22/11/2017	ROADS2000	1.5 T OF 7MM RED LATERITE 2% RED OXIDE TO BE PICKED UP 21 NOVEMBER 2017	1	414.69	
EFT28422	30/11/2017	ROWLANDS TV & VIDEO REPAIRS	LOCATE & REPAIR FAULTY SPLITTER CONNECTIONS, REPLACE FAULTY WALL OUTLET AND POWER SUPPLY. SUPPLY NEW FLYLEADS.	1		231.90

Date: 01/12/2017
Time: 9:08:54AM

Shire of Northam

USER: Kathy Scholz
PAGE: 49

Cheque / EFT No	Date	Name	Invoice Description	Bank Code	INV Amount	Amount
INV 24054	22/11/2017	ROWLANDS TV & VIDEO REPAIRS	LOCATE & REPAIR FAULTY SPLITTER CONNECTIONS, REPLACE FAULTY WALL OUTLET AND POWER SUPPLY SUPPLY NEW FLYLEADS.	1	231.90	
EFT28423	30/11/2017	SAWYERS VALLEY BASKETBALL CLUB	KIDSPORT FUNDING	1		80.00
INV KS01521	29/11/2017	SAWYERS VALLEY BASKETBALL CLUB	KIDSPORT FUNDING	1	80.00	
EFT28424	30/11/2017	SIGMA CHEMICALS	EQUIPMENT FOR THE WUNDOWIE POOL.	1		38.24
INV 108975	01/11/2017	SIGMA CHEMICALS	EQUIPMENT FOR THE WUNDOWIE POOL.	1	38.24	
EFT28425	30/11/2017	SKILL HIRE WA PTY LTD	LABOUR HIRE - ROB WILSON - 29/10/2017.	1		17,377.45
INV AP51107	09/11/2017	SKILL HIRE WA PTY LTD	LABOUR HIRE FOR NICHOLAS SCHEER FOR THE WEEK ENDING 05/11/2017.	1	2,208.12	
INV AP51089	30/11/2017	SKILL HIRE WA PTY LTD	LABOUR HIRE FOR NICHOLAS SCHEER FOR THE WEEK ENDING 22/10/2017.	1	2,173.58	
INV AP51185	22/11/2017	SKILL HIRE WA PTY LTD	LABOUR HIRE FOR ROBERT WILSON FOR THE WEEK ENDING 19/11/2017.	1	1,676.38	
INV AP51104	09/11/2017	SKILL HIRE WA PTY LTD	LABOUR HIRE - ROB WILSON - 05/11/2017.	1	1,804.94	
INV AP51045	27/10/2017	SKILL HIRE WA PTY LTD	LABOUR HIRE - ROB WILSON - 16/10/2017.	1	1,701.34	
INV AP50927	10/10/2017	SKILL HIRE WA PTY LTD	LABOUR HIRE - ROB WILSON - 08/10/2017.	1	1,591.91	
INV AP51087	02/11/2017	SKILL HIRE WA PTY LTD	LABOUR HIRE - ROB WILSON - 29/10/2017.	1	4,013.06	
INV AP51143	16/11/2017	SKILL HIRE WA PTY LTD	LABOUR HIRE - ROB WILSON - 12/11/2017.	1	2,208.12	
EFT28426	30/11/2017	SLATER-GARTRELL SPORTS	BLACK LINE MARKING PAINT FOR SPORTS OVALS	1		492.80
INV SG24721	16/11/2017	SLATER-GARTRELL SPORTS	BLACK LINE MARKING PAINT FOR SPORTS OVALS	1	246.40	
INV SG24728	16/11/2017	SLATER-GARTRELL SPORTS	BLACK LINE MARKING PAINT FOR SPORTS OVALS	1	246.40	
EFT28427	30/11/2017	SOUTHERN METROPOLITAN REGIONAL COUNCIL.	6200 RECYCLE RIGHT WASTE CALENDARS FOR THE SHIRE OF NORTHAM. CALENDARS TO BE DELIVERED TO ZIPFORM (191 BANNISTER ROAD, CANNING VALE).	1		4,866.40
INV 12786	01/11/2017	SOUTHERN METROPOLITAN REGIONAL COUNCIL.	6200 RECYCLE RIGHT WASTE CALENDARS FOR THE SHIRE OF NORTHAM. CALENDARS TO BE DELIVERED TO ZIPFORM (191 BANNISTER ROAD, CANNING VALE).	1	4,866.40	

Date: 01/12/2017
Time: 9:08:54AM

Shire of Northam

USER: Kathy Scholz
PAGE: 50

Cheque / EFT No	Date	Name	Invoice Description	Bank Code	INV Amount	Amount
EFT28429	30/11/2017	THE WEST AUSTRALIAN	BALLOON FIESTA ADS IN THE COUNTRYMAN ON THE 24/08/17 & 31/08/17.	1		1,100.00
INV 1009587531/08/2017		THE WEST AUSTRALIAN	BALLOON FIESTA ADS IN THE COUNTRYMAN ON THE 24/08/17 & 31/08/17.	1	1,100.00	
EFT28430	30/11/2017	THE WORKWEAR GROUP	SAMPLE UNIFORMS FOR KILLARA	1		164.90
INV 0302340308/11/2017		THE WORKWEAR GROUP	SAMPLE UNIFORMS FOR KILLARA	1	164.90	
EFT28431	30/11/2017	TYRECYCLE PTY LTD	RECYCLING OF VARIOUS TYRES AT INKPEN REFUSE SITE.	1		3,967.25
INV 656846	20/10/2017	TYRECYCLE PTY LTD	Truck Tyre	1	1,447.22	
INV 659600	03/11/2017	TYRECYCLE PTY LTD	RECYCLING OF VARIOUS TYRES AT INKPEN REFUSE SITE.	1	2,520.03	
EFT28432	30/11/2017	VERNICE PTY LTD	EMERGENCY HIRE OF EXCAVATOR FOR GREEN WASTE FIRE.	1		5,668.85
INV 5485	24/10/2017	VERNICE PTY LTD	EMERGENCY HIRE OF EXCAVATOR FOR GREEN WASTE FIRE.	1	5,668.85	
EFT28433	30/11/2017	VICTORIA WILLIAMS	CHRISTMAS TREE, DECORATIONS & DOORMAT FOR CUSTOMER SERVICE AREAS AT VISITORS CENTRE.	1		36.50
INV RR2911209/11/2017		VICTORIA WILLIAMS	CHRISTMAS TREE, DECORATIONS & DOORMAT FOR CUSTOMER SERVICE AREAS AT VISITORS CENTRE.	1	36.50	
EFT28434	30/11/2017	WHEATBELT OFFICE & BUSINESS MACHINES	TP-LINK NETWORK CARD FOR NSC-FINADMIN	1		21.00
INV 22689	14/11/2017	WHEATBELT OFFICE & BUSINESS MACHINES	TP-LINK NETWORK CARD FOR NSC-FINADMIN	1	21.00	
EFT28435	30/11/2017	WINC AUSTRALIA PTY LIMITED	STATIONERY FOR SHIRE ADMIN.	1		584.16
INV 9022598827/10/2017		WINC AUSTRALIA PTY LIMITED	STATIONERY FOR SHIRE ADMIN BUILDING.	1	195.61	
INV 9022776216/11/2017		WINC AUSTRALIA PTY LIMITED	STATIONERY FOR SHIRE ADMIN.	1	388.55	
EFT28436	30/11/2017	WREN OIL	OIL WASTE DISPOSAL	1		33.00
INV 42648	31/10/2017	WREN OIL	OIL WASTE DISPOSAL	1	16.50	
INV 42650	31/10/2017	WREN OIL	OIL WASTE DISPOSAL	1	16.50	

Date: 01/12/2017
Time: 9:08:54AM

Shire of Northam

USER: Kathy Scholz
PAGE: 51

Cheque / EFT No	Date	Name	Invoice Description	Bank Code	INV Amount	Amount
34836	03/11/2017	PETTY CASH	PETTY CASH REIMBURSEMENT FOR KILLARA FROM 16/8/2017 TO 21/08/2017.	1		494.95
INV KILLAR/21/08/2017		PETTY CASH	PETTY CASH REIMBURSEMENT FOR KILLARA FROM 16/8/2017 TO 21/08/2017.	1	494.95	
34837	03/11/2017	SHIRE OF NORTHAM	AROC MEMBERSHIP FINANCIAL YEAR 2017/18	1		5,500.00
INV 009	31/10/2017	SHIRE OF NORTHAM	AROC MEMBERSHIP FINANCIAL YEAR 2017/18	1	5,500.00	
34838	03/11/2017	SYNERGY	SHIRE ADMIN BUILDING 21/09/2017 TO 19/10/2017.	1		5,726.20
INV 1819945019/10/2017		SYNERGY	KILLARA NEW BUILDING 21/09/2017 to 19/10/2017		1,243.25	
INV 9168227520/10/2017		SYNERGY	WUNDOWIE TENNIS CLUB 22/08/2017 to 20/10/2017.		50.80	
INV 3053076120/10/2017		SYNERGY	LOT 410 KURINGAL RD WUNDOWIE 23/8/2017 TO 20/10/2017		58.85	
INV 3006770720/10/2017		SYNERGY	WUNDOWIE FOOTY PAVILLION 22/08/2017 to 20/10/2017.		84.15	
INV 3619900320/10/2017		SYNERGY	WUNDOWIE OVAL PUMP 22/08/2017 to 20/10/2017.		166.10	
INV 3706392320/10/2017		SYNERGY	WUNDOWIE TOWN HALL 22/08/2017 to 20/10/2017.		467.05	
INV 4449973020/10/2017		SYNERGY	WUNDOWIE LIBRARY 22/08/2017 TO 20/10/2017		543.15	
INV 1422759520/10/2017		SYNERGY	WUNDOWIE OVAL 22/8/2017 to 20/10/2017		289.45	
INV 9626429920/10/2017		SYNERGY	MEDICAL CENTRE 22/08/2017 to 20/10/2017.		31.45	
INV 0353464123/10/2017		SYNERGY	HOOPER PARK GEH B/HILL 23/8/2017 TO 23/10/2017.		98.00	
INV 7968413419/10/2017		SYNERGY	SHIRE ADMIN BUILDING 21/09/2017 TO 19/10/2017.		1,323.85	
INV 9812925719/10/2017		SYNERGY	BAKERS HILL REC CENTRE 21/08/2017 TO 19/10/2017.		726.85	
INV 1640077120/10/2017		SYNERGY	WUNDOWIE DEPOT 22/8/2017 TO 20/10/2017.	1	603.30	
INV 4879640420/10/2017		SYNERGY	YOUTH ADVISORY 22/8/2017 TO 20/10/2017.	1	39.95	
34839	03/11/2017	WATER CORPORATION	WUNDOWIE SWIMMING POOL 23/08/2017 TO 20/10/2017	1		3,580.13
INV 9007943520/10/2017		WATER CORPORATION	STANDPIPE AT AVRO ANSON RD 19/08/2017 TO 19/10/2017		7.17	
INV 9007909708/09/2017		WATER CORPORATION	REC CENTRE 11/7/2017 TO 07/9/2017		204.73	
INV 9007872323/10/2017		WATER CORPORATION	UNIT 8/410L KURINGAL RD WUNDOWIE 23/08/2017 TO 20/10/2017		238.85	

Date: 01/12/2017
Time: 9:08:54AM

Shire of Northam

USER: Kathy Scholz
PAGE: 52

Cheque / EFT No	Date	Name	Invoice Description	Bank Code	INV Amount	Amount
INV 9007872323/10/2017		WATER CORPORATION	UNIT 7/410L KURINGAL RD WUNDOWIE 23/08/2017 TO 20/10/2017		232.58	
INV 9007872223/10/2017		WATER CORPORATION	UNIT 6/410L KURINGAL RD WUNDOWIE 23/08/2017 TO 20/10/2017		234.64	
INV 9007872223/10/2017		WATER CORPORATION	UNIT 5/410L KURINGAL RD WUNDOWIE 23/8/2017 TO 20/10/2017.		235.48	
INV 9007872223/10/2017		WATER CORPORATION	UNIT 4/410L KURINGAL RD WUNDOWIE 23/08/2017 TO 20/10/2017		234.64	
INV 9007872223/10/2017		WATER CORPORATION	UNIT 3/410L KURINGAL RD WUNDOWIE 23/08/2017 TO 20/10/2017		228.76	
INV 9007872223/10/2017		WATER CORPORATION	UNIT 2/410L KURINGAL RD WUNDOWIE 23/08/2017 TO 20/10/2017		214.09	
INV 9007872223/10/2017		WATER CORPORATION	410L KURINGAL RD WUNDOWIE 23/08/2017 TO 20/10/2017		41.85	
INV 9007871923/10/2017		WATER CORPORATION	DEPOT - WUNDOWIE 23/08/2017 TO 20/10/2017		19.13	
INV 9007871923/10/2017		WATER CORPORATION	WUNDOWIE OVAL 23/08/2017 TO 20/10/2017		193.13	
INV 9007871823/10/2017		WATER CORPORATION	RESERVE AT BANKSIA AVE 23/08/2017 TO 20/10/2017		190.74	
INV 9007869123/10/2017		WATER CORPORATION	HALL AT BANKSIA AV WUNDOWIE 23/08/2017 TO 20/10/2017		241.51	
INV 9007869123/10/2017		WATER CORPORATION	LIBRARY - WUNDOWIE 23/08/2017 TO 20/10/2017		141.51	
INV 9007869123/10/2017		WATER CORPORATION	KINDERGARDEN - WUNDOWIE 23/08/2017 TO 20/10/2017		91.85	
INV 9007868923/10/2017		WATER CORPORATION	TOILETS AT BANKSIA AV WUNDOWIE 23/08/2017 TO 20/10/2017		121.25	
INV 9007868623/10/2017		WATER CORPORATION	WUNDOWIE YOUTH CENTRE 23/08/2017 TO 20/10/2017		4.78	
INV 9007868523/10/2017		WATER CORPORATION	WUNDOWIE SWIMMING POOL 23/08/2017 TO 20/10/2017		496.08	
INV 9007872223/10/2017		WATER CORPORATION	UNIT 1/410 KURINGAL RD WUNDOWIE - 23/8/2017 TO 20/10/2017	1	207.36	
34840	10/11/2017	SHIRE OF NORTHAM	10 X WALGA COUNCILLOR TRAINING 26 & 27 OCTOBER 2017 - FOR TERRY LITTLE, CARL DELLA, ATILLA MENCSELYI, CHRIS ANTONIO & MICHAEL RYAN (TO BE BANKED IN TRUST T957).	1		4,345.00
INV 013	08/11/2017	SHIRE OF NORTHAM	10 X WALGA COUNCILLOR TRAINING 26 & 27 OCTOBER 2017 - FOR TERRY LITTLE, CARL DELLA, ATILLA MENCSELYI, CHRIS ANTONIO & MICHAEL RYAN (TO BE BANKED IN TRUST T957).	1	4,345.00	

Date: 01/12/2017
Time: 9:08:54AM

Shire of Northam

USER: Kathy Scholz
PAGE: 53

Cheque / EFT No	Date	Name	Invoice Description	Bank Code	INV Amount	Amount
34841	10/11/2017	SYNERGY	STREET LIGHTS - 02/10/2017 TO 01/11/2017.	1		22,897.90
INV 9152416401/11/2017		SYNERGY	AUXILLARY LIGHTING - 02/10/2017 TO 01/11/2017.	1	125.50	
INV 1686149901/11/2017		SYNERGY	STREET LIGHTS - 02/10/2017 TO 01/11/2017.	1	22,772.40	
34842	10/11/2017	TELSTRA CORPORATION	MOBILES - OCTOBER- NOVEMBER 2017.	1		4,175.11
INV 6305302927/10/2017		TELSTRA CORPORATION	BAKERS HILL BFB - 23/9/2017 TO 22/10/2017.	1	35.54	
INV 2726008928/10/2017		TELSTRA CORPORATION	MOBILES - OCTOBER- NOVEMBER 2017.	1	4,139.57	
34843	10/11/2017	WATER CORPORATION	STANDPIPE AT IRISHTOWN RD 06/9/2017 TO 02/11/2017.	1		174.57
INV 9007948303/11/2017		WATER CORPORATION	STANDPIPE AT IRISHTOWN RD 06/9/2017 TO 02/11/2017.	1	49.02	
INV 9007948203/11/2017		WATER CORPORATION	STANDPIPE AT KATRINE TOILETS 06/09/2017 TO 02/09/2017.	1	41.85	
INV 9007946102/11/2017		WATER CORPORATION	STANDPIPE AT SPENCERS BROOK RD - 06/9/2017 TO 01/11/2017.	1	41.85	
INV 9007945602/11/2017		WATER CORPORATION	STANDPIPE NORTHAM-TOODYAY 02/09/2017 TO 01/11/2017.	1	41.85	
34844	17/11/2017	PETTY CASH	PETTY CASH REIMBURSEMENT FOR REC CENTRE - 11/9/2017 TO 21/10/2017.	1		266.16
INV P/C KILL31/10/2017		PETTY CASH	PETTY CASH REIMBURSEMENT FOR KILLARA. 21/8/2017 TO 31/10/2017.	1	79.15	
INV P/C REC 21/10/2017		PETTY CASH	PETTY CASH REIMBURSEMENT FOR REC CENTRE - 11/9/2017 TO 21/10/2017.	1	187.01	
34845	17/11/2017	SHIRE OF NORTHAM SOCIAL CLUB	Payroll deductions	1		135.00
INV DEDUCT14/11/2017		SHIRE OF NORTHAM SOCIAL CLUB	Payroll deductions		135.00	
34846	17/11/2017	SYNERGY	ELECTRICITY FOR VARIOUS SHIRE PROPERTIES FROM 05/10/2017 TO 03/11/2017.	1		3,740.21
INV 7471705309/11/2017		SYNERGY	SKATE PARK 11/9/2017 TO 09/11/2017.	1	43.75	
INV 5140678109/11/2017		SYNERGY	BERT HAWKE OVAL RETICULATION 11/9/2017 TO 09/11/2017.	1	1,015.25	
INV 0929125208/11/2017		SYNERGY	GRASS VALLEY OVAL 08/09/2017 TO 08/11/2017.	1	31.80	
INV 7921766203/11/2017		SYNERGY	ELECTRICITY FOR VARIOUS SHIRE PROPERTIES FROM 05/10/2017 TO 03/11/2017.	1	2,649.41	

Date: 01/12/2017
Time: 9:08:54AM

Shire of Northam

USER: Kathy Scholz
PAGE: 54

Cheque / EFT No	Date	Name	Invoice Description	Bank Code	INV Amount	Amount
34848	23/11/2017	DEPARTMENT OF MINES AND PETROLEUM	ANNUAL LICENCE FOR LOT 28055 COLEBATCH RD (SEWERAGE EFFLUENT TREATMENT PLANT).	1		202.00
INV DGS012626/10/2017		DEPARTMENT OF MINES AND PETROLEUM	ANNUAL LICENCE FOR LOT 28055 COLEBATCH RD (SEWERAGE EFFLUENT TREATMENT PLANT).	1	202.00	
34849	23/11/2017	PETTY CASH	PETTY CASH REIMBURSEMENT FOR SHIRE ADMIN - FROM 11/7/2017 TO 16/11/2017.	1		384.10
INV P/C ADM16/11/2017		PETTY CASH	PETTY CASH REIMBURSEMENT FOR SHIRE ADMIN - FROM 11/7/2017 TO 16/11/2017.	1	384.10	
34850	23/11/2017	SYNERGY	AIRPORT - 08/09/2017 TO 07/11/2017.	1		3,726.90
INV 9848165906/11/2017		SYNERGY	PAYMENT ON BEHALF OF CLACKLINE PROGRESS ASSOCIATION AS PER MINUTE 3141 20/9/2017.	1	62.35	
INV 1365377414/11/2017		SYNERGY	AIRPORT - 08/09/2017 TO 07/11/2017.	1	2,622.60	
INV 1819945016/11/2017		SYNERGY	KILLARA NEW BUILDINGS - 19/10/2017 TO 16/11/2017.	1	903.25	
INV 9414532308/11/2017		SYNERGY	GRASS VALLEY FIRE SHED - 05/9/2017 TO 02/11/2017.	1	138.70	
34851	23/11/2017	TELSTRA CORPORATION	MAINLINE PHONE ACCOUNT 04/11/2017 to 04/12/2017.	1		5,531.14
INV 3864754804/12/2017		TELSTRA CORPORATION	HENRY ST OVAL 04/11/2017 TO 04/12/2017.		72.32	
INV 2726008910/11/2017		TELSTRA CORPORATION	BUSHFIRE BRIGADE 10/11/2017 TO 09/12/2017.	1	176.95	
INV 9026075012/11/2017		TELSTRA CORPORATION	MAINLINE PHONE ACCOUNT 04/11/2017 to 04/12/2017.		5,241.92	
INV 2000490620/11/2017		TELSTRA CORPORATION	SES ACCOUNT 15/10/2017 TO 14/11/2017.		39.95	
34852	23/11/2017	WATER CORPORATION	RECREATION CENTRE 13/9/2017 TO 10/11/2017	1		14,266.89
INV 9007907209/11/2017		WATER CORPORATION	WATER CHARGES - 182 FITZGERALD STREET, NORTHAM ACCOUNT:90 07907 298	1	380.39	
INV 9007945309/11/2017		WATER CORPORATION	STANDPIPE AT MEENAAR FROM 14/9/2017 TO 08/11/2017.	1	41.85	
INV 9007948403/11/2017		WATER CORPORATION	IRISHTOWN AGRICULTURAL HALL. 06/9/2017 to 02/11/2017.	1	2.39	
INV 9007945102/11/2017		WATER CORPORATION	TOILETS AT KATRINE RD 02/9/2017 to 01/11/2017.	1	497.33	
INV 9007929409/11/2017		WATER CORPORATION	AVON MALL 12/9/2017 to 08/11/2017.	1	671.87	
INV 9012642709/11/2017		WATER CORPORATION	GARDEN AT NIND ST 08/9/2017 to 08/11/2017.	1	4.78	
INV 9007909708/11/2017		WATER CORPORATION	JUBILEE OVAL 08/9/2017 to 07/11/2017.	1	541.69	

Date: 01/12/2017
Time: 9:08:54AM

Shire of Northam

USER: Kathy Scholz
PAGE: 55

Cheque / EFT No	Date	Name	Invoice Description	Bank Code	INV Amount	Amount
INV 9007908608/11/2017		WATER CORPORATION	KILLARA 08/9/2017 to 07/11/2017.	1	1,123.20	
INV 9007908008/11/2017		WATER CORPORATION	OLD GIRLS SCHOOL 08/9/2017 to 07/11/2017.	1	60.77	
INV 9007908008/11/2017		WATER CORPORATION	OLD POST OFFICE BUILDING 08/9/2017 to 07/11/2017.	1	84.68	
INV 9011070409/11/2017		WATER CORPORATION	SNACKBAR AT GREY ST 01/11/2017 to 31/12/2017.	1	198.93	
INV 9007907409/11/2017		WATER CORPORATION	BERNARD PARK PLAYCENTRE 12/9/2017 to 08/11/2017.	1	115.21	
INV 9007907409/11/2017		WATER CORPORATION	BERNARD PARK 12/9/2017 to 08/11/2017.	1	1,246.60	
INV 9007907309/11/2017		WATER CORPORATION	RIVERBANK TO BROOME TCE 12/9/2017 to 08/11/2017.	1	38.26	
INV 9007906908/11/2017		WATER CORPORATION	OLD INFANT HEALTH CLINIC 08/9/2017 to 07/11/2017.	1	58.95	
INV 9007906708/11/2017		WATER CORPORATION	OLD FIRE STATION 08/9/2017 to 07/11/2017.	1	137.28	
INV 9007904009/11/2017		WATER CORPORATION	LIBRARY 12/9/2017 to 08/11/2017.	1	106.20	
INV 9007904009/11/2017		WATER CORPORATION	OLD TOWN BUILDING 12/9/2017 to 08/11/2017.	1	99.59	
INV 9007904009/11/2017		WATER CORPORATION	MEMORIAL HALL 12/9/2017 to 08/11/2017.	1	247.57	
INV 9007903909/11/2017		WATER CORPORATION	ST JOHN'S HALL 12/9/2017 to 08/11/2017.	1	148.11	
INV 9007903707/11/2017		WATER CORPORATION	TOWN & LESSER HALL 07/9/2017 to 06/11/2017.	1	356.63	
INV 9007901706/11/2017		WATER CORPORATION	PURSLOWE PARK 06/9/2017 to 03/11/2017.	1	184.11	
INV 9007901606/11/2017		WATER CORPORATION	RAILWAY MUSEUM 06/9/2017 to 03/11/2017.	1	142.21	
INV 9007899906/11/2017		WATER CORPORATION	GIRL GUIDES HALL 06/9/2017 to 03/11/2017.	1	65.55	
INV 9008729809/11/2017		WATER CORPORATION	VISITORS CENTRE 12/9/2017 to 08/11/2017.	1	642.01	
INV 9008729706/11/2017		WATER CORPORATION	SHIRE ADMIN 06/9/2017 to 03/11/2017.	1	268.86	
INV 9007904007/11/2017		WATER CORPORATION	VACANT LAND 274 FITZGERALD STREET 07/9/2017 to 06/11/2017.	1	5.60	
INV 9007923414/11/2017		WATER CORPORATION	APEX PARK TOILETS 15/9/2017 TO 13/11/2017		100.86	
INV 9007917014/11/2017		WATER CORPORATION	CEMETERY 14/9/2017 TO 13/11/2017		94.34	
INV 9007916614/11/2017		WATER CORPORATION	MORBY COTTAGE 14/9/2017 TO 13/11/2017		63.70	
INV 9007915514/11/2017		WATER CORPORATION	AIRPORT 15/9/2017 TO 13/11/2017		1,275.66	
INV 9012475715/11/2017		WATER CORPORATION	GARDEN AT TAYLOR ST (VACANT LAND) 14/9/2017 TO 13/11/2017		33.47	

Date: 01/12/2017
Time: 9:08:54AM

Shire of Northam

USER: Kathy Scholz
PAGE: 56

Cheque / EFT No	Date	Name	Invoice Description	Bank Code	INV Amount	Amount
INV 9007913510/11/2017		WATER CORPORATION	DEPOT AT 116 PEEB TCE 13/9/2017 TO 09/11/2017		1,468.07	
INV 9007913110/11/2017		WATER CORPORATION	DEPOT BUILDING 67 BYFIELD ST 13/9/2017 TO 09/11/2017		138.68	
INV 9007909713/11/2017		WATER CORPORATION	RECREATION CENTRE 13/9/2017 TO 10/11/2017		3,126.04	
INV 9007908710/11/2017		WATER CORPORATION	MAY STREET PRE-PRIMARY 12/9/2017 TO 11/11/2017	1	453.60	
INV 9007951310/11/2017		WATER CORPORATION	STANDPIPE AT MEENAAR SOUTH RD 14/9/2017 TO 09/11/2017		-41.85	
34853	29/11/2017	COMMISSIONER OF POLICE	APPLICATION FOR CATERGORY 4 ROAD CLOSURE.	1		80.60
INV VW2411224/11/2017		COMMISSIONER OF POLICE	APPLICATION FOR CATERGORY 4 ROAD CLOSURE.	1	80.60	
34854	30/11/2017	SHIRE OF NORTHAM SOCIAL CLUB	Payroll deductions	1		145.00
INV DEDUCT28/11/2017		SHIRE OF NORTHAM SOCIAL CLUB	Payroll deductions		145.00	
34855	30/11/2017	SYNERGY	SHIRE ADMIN BUILDING 19/10/2017 TO 16/11/2017.	1		1,494.45
INV 7968413416/11/2017		SYNERGY	SHIRE ADMIN BUILDING 19/10/2017 TO 16/11/2017.	1	1,494.45	
34856	30/11/2017	WATER CORPORATION	NORTHAM SWIMMING POOL MITCHELL 22/09/2017 TO 17/11/2017.	1		8,129.81
INV 9021499420/11/2017		WATER CORPORATION	NORTHAM SWIMMING POOL MITCHELL 22/09/2017 TO 17/11/2017.		6,357.71	
INV 9007938920/11/2017		WATER CORPORATION	STANDPIPE BODEGUERO WAY 28/09/2017 TO 17/11/2017.		41.85	
INV 9007927520/11/2017		WATER CORPORATION	RUBBISH DEPOT AT OLD QUARRY RD 22/09/2017 TO 17/11/2017.		66.95	
INV 9007925920/11/2017		WATER CORPORATION	ANIMAL POUND AT OLD QUARRY 22/09/2017 TO 17/11/2017.		62.17	
INV 9007925917/11/2017		WATER CORPORATION	LOT 28472 RES NEWCASTLE RD 21/9/2017 TO 16/11/2017.		322.79	
INV 9007923620/11/2017		WATER CORPORATION	HOUSE AT 55 MITCHELL AVE 22/09/2017 TO 17/11/2017.		237.32	
INV 9007923520/11/2017		WATER CORPORATION	MEDIAN STRIP ON NEWCASTLE RD 21/09/2017 TO 17/11/2017.		4.78	
INV 9007918417/11/2017		WATER CORPORATION	PLAYGROUND AT PERINA WAY 21/9/2017 TO 16/11/2017.		133.90	
INV 9007917216/11/2017		WATER CORPORATION	BERT HAWKE OVAL 21/09/2017 TO 15/11/2017.		396.91	
INV 9007909708/11/2017		WATER CORPORATION	SES BUILDING 08/09/2017 TO 07/11/2017.		138.68	

Date: 01/12/2017
Time: 9:08:54AM

Shire of Northam

USER: Kathy Scholz
PAGE: 57

Cheque / EFT No	Date	Name	Invoice Description	Bank Code	INV Amount	Amount
INV 9012562920/11/2017		WATER CORPORATION	ROAD VERGE AT MITCHELL AVENUE 22/09/2017 TO 17/11/2017.	1	102.81	
INV 9022053216/11/2017		WATER CORPORATION	STANDPIPE AT CLARKE STREET 16/9/2017 TO 15/11/2017	1	261.55	
INV 9007909908/11/2017		WATER CORPORATION	SHED AT HENRY ST NORTHAM 08/9/2017 TO 07/11/2017	1	2.39	
DD11877.1	13/11/2017	BANKWEST	ROSS RAYSON MASTERCARD 22/9/17 TO 23/10/17	1		8,363.60
INV C HUNT	13/11/2017	BANKWEST	CHADD HUNT MASTERCARD 22/9/17 TO 23/10/17	1	1,847.38	
INV J WHITE.	13/11/2017	BANKWEST	JASON WHITEAKER MASTERCARD 22/9/17 TO 23/10/17	1	2,871.61	
INV C YOUNG	13/11/2017	BANKWEST	COLIN YOUNG MASTERCARD 22/9/17 TO 23/10/17	1	19.99	
INV C KLEYM	13/11/2017	BANKWEST	C KLEYNHANS MASTERCARD 22/9/17 TO 23/10/17	1	353.47	
INV D HENRI	13/11/2017	BANKWEST	DANIEL HENDRIKSEN MASTERCARD 22/9/17 TO 23/10/17	1	663.94	
INV R RAYSC	13/11/2017	BANKWEST	ROSS RAYSON MASTERCARD 22/9/17 TO 23/10/17	1	2,607.21	
DD11883.1	14/11/2017	WA SUPER	Payroll deductions	1		23,718.56
INV SUPER	14/11/2017	WA SUPER	Superannuation contributions	1	20,946.74	
INV DEDUCT	14/11/2017	WA SUPER	Payroll deductions	1	1,599.25	
INV DEDUCT	14/11/2017	WA SUPER	Payroll deductions	1	94.69	
INV DEDUCT	14/11/2017	WA SUPER	Payroll deductions	1	37.98	
INV DEDUCT	14/11/2017	WA SUPER	Payroll deductions	1	295.73	
INV DEDUCT	14/11/2017	WA SUPER	Payroll deductions	1	25.00	
INV DEDUCT	14/11/2017	WA SUPER	Payroll deductions	1	349.77	
INV DEDUCT	14/11/2017	WA SUPER	Payroll deductions	1	44.40	
INV DEDUCT	14/11/2017	WA SUPER	Payroll deductions	1	323.00	
DD11883.2	14/11/2017	NETWEALTH SUPERANNUATION	Superannuation contributions	1		258.59
INV SUPER	14/11/2017	NETWEALTH SUPERANNUATION	Superannuation contributions	1	258.59	
DD11883.3	14/11/2017	BENDIGO SMART START SUPER	Superannuation contributions	1		191.36
INV SUPER	14/11/2017	BENDIGO SMART START SUPER	Superannuation contributions	1	191.36	

Date: 01/12/2017
Time: 9:08:54AM

Shire of Northam

USER: Kathy Scholz
PAGE: 58

Cheque / EFT No	Date	Name	Invoice Description	Bank Code	INV Amount	Amount
DD11883.4	14/11/2017	SUNSUPER	Superannuation contributions	1		450.84
INV SUPER	14/11/2017	SUNSUPER	Superannuation contributions	1	450.84	
DD11883.5	14/11/2017	VISION SUPER	Superannuation contributions	1		148.55
INV SUPER	14/11/2017	VISION SUPER	Superannuation contributions	1	148.55	
DD11883.6	14/11/2017	HSTPLUS SUPER	Superannuation contributions	1		84.76
INV SUPER	14/11/2017	HSTPLUS SUPER	Superannuation contributions	1	84.76	
DD11883.7	14/11/2017	HESTA SUPER FUND	Superannuation contributions	1		144.69
INV SUPER	14/11/2017	HESTA SUPER FUND	Superannuation contributions	1	144.69	
DD11883.8	14/11/2017	KINETIC SUPER	Superannuation contributions	1		144.30
INV SUPER	14/11/2017	KINETIC SUPER	Superannuation contributions	1	144.30	
DD11883.9	14/11/2017	ESSENTIAL SUPER	Superannuation contributions	1		146.79
INV SUPER	14/11/2017	ESSENTIAL SUPER	Superannuation contributions	1	146.79	
DD11902.1	14/11/2017	WA SUPER	Superannuation contributions	1		83.42
INV SUPER	22/11/2017	WA SUPER	Superannuation contributions	1	83.42	
DD11920.1	29/11/2017	TENNANT AUSTRALIA	LEASE CLEANING FEE NOVEMBER 2017 -NORTHAM RECREATION CENTRE	1		1,046.85
INV NOVEM129/11/2017	29/11/2017	TENNANT AUSTRALIA	LEASE CLEANING FEE NOVEMBER 2017 -NORTHAM RECREATION CENTRE	1	1,046.85	
DD11927.1	28/11/2017	WA SUPER	Payroll deductions	1		23,111.09
INV SUPER	28/11/2017	WA SUPER	Superannuation contributions	1	20,344.70	
INV DEDUCT28/11/2017	28/11/2017	WA SUPER	Payroll deductions	1	1,590.22	
INV DEDUCT28/11/2017	28/11/2017	WA SUPER	Payroll deductions	1	97.69	
INV DEDUCT28/11/2017	28/11/2017	WA SUPER	Payroll deductions	1	39.11	
INV DEDUCT28/11/2017	28/11/2017	WA SUPER	Payroll deductions	1	295.73	

Date: 01/12/2017
Time: 9:08:54AM

Shire of Northam

USER: Kathy Scholz
PAGE: 59

Cheque / EFT No	Date	Name	Invoice Description	Bank Code	INV Amount	Amount
INV DEDUCT28/11/2017		WA SUPER	Payroll deductions	1	25.00	
INV DEDUCT28/11/2017		WA SUPER	Payroll deductions	1	349.24	
INV DEDUCT28/11/2017		WA SUPER	Payroll deductions	1	44.40	
INV DEDUCT28/11/2017		WA SUPER	Payroll deductions	1	325.00	
DD11927.2	28/11/2017	AMG UNIVERSAL SUPER	Superannuation contributions	1		173.95
INV SUPER	28/11/2017	AMG UNIVERSAL SUPER	Superannuation contributions	1	173.95	
DD11927.3	28/11/2017	NET WEALTH SUPERANNUATION	Superannuation contributions	1		258.59
INV SUPER	28/11/2017	NET WEALTH SUPERANNUATION	Superannuation contributions	1	258.59	
DD11927.4	28/11/2017	BENDIGO SMART START SUPER	Superannuation contributions	1		191.96
INV SUPER	28/11/2017	BENDIGO SMART START SUPER	Superannuation contributions	1	191.96	
DD11927.5	28/11/2017	SUNSUPER	Superannuation contributions	1		451.40
INV SUPER	28/11/2017	SUNSUPER	Superannuation contributions	1	451.40	
DD11927.6	28/11/2017	VISION SUPER	Superannuation contributions	1		191.39
INV SUPER	28/11/2017	VISION SUPER	Superannuation contributions	1	191.39	
DD11927.7	28/11/2017	HOSTPLUS SUPER	Superannuation contributions	1		370.28
INV SUPER	28/11/2017	HOSTPLUS SUPER	Superannuation contributions	1	370.28	
DD11927.8	28/11/2017	UNISUPER	Superannuation contributions	1		68.25
INV SUPER	28/11/2017	UNISUPER	Superannuation contributions	1	68.25	
DD11927.9	28/11/2017	KINETIC SUPER	Superannuation contributions	1		144.30
INV SUPER	28/11/2017	KINETIC SUPER	Superannuation contributions	1	144.30	
DD11883.10	14/11/2017	ANZ SMART CHOICE SUPER (ONEPATH MASTERFUND)	Superannuation contributions	1		204.41
INV SUPER	14/11/2017	ANZ SMART CHOICE SUPER (ONEPATH MASTERFUND)	Superannuation contributions	1	204.41	

Date: 01/12/2017
Time: 9:08:54AM

Shire of Northam

USER: Kathy Scholz
PAGE: 60

Cheque / EFT No	Date	Name	Invoice Description	Bank Code	INV Amount	Amount
DD1883.11	14/11/2017	CBUS	Superannuation contributions	1		188.54
INV SUPER	14/11/2017	CBUS	Superannuation contributions	1	188.54	
DD1883.12	14/11/2017	AUSTRALIAN SUPER PTY LTD	Superannuation contributions	1		1,868.36
INV SUPER	14/11/2017	AUSTRALIAN SUPER PTY LTD	Superannuation contributions	1	1,868.36	
DD1883.13	14/11/2017	REST INDUSTRY SUPER	Superannuation contributions	1		649.76
INV SUPER	14/11/2017	REST INDUSTRY SUPER	Superannuation contributions	1	649.76	
DD1883.14	14/11/2017	CONCEPT ONE THE INDUSTRY SUPERANNUATION FUND	Superannuation contributions	1		292.89
INV SUPER	14/11/2017	CONCEPT ONE THE INDUSTRY SUPERANNUATION FUND	Superannuation contributions	1	292.89	
DD1883.15	14/11/2017	ZURICH AUSTRALIA LIMITED	Superannuation contributions	1		254.29
INV SUPER	14/11/2017	ZURICH AUSTRALIA LIMITED	Superannuation contributions	1	254.29	
DD1883.16	14/11/2017	IOOF PORTFOLIO SERVICE SUPERANNUATION FUND	Superannuation contributions	1		351.46
INV SUPER	14/11/2017	IOOF PORTFOLIO SERVICE SUPERANNUATION FUND	Superannuation contributions	1	351.46	
DD1883.17	14/11/2017	(THE QUEENSLAND LOCAL GOVERNMENT SUPERANNUATION BOARD) LG SUPER	Superannuation contributions	1		208.24
INV SUPER	14/11/2017	(THE QUEENSLAND LOCAL GOVERNMENT SUPERANNUATION BOARD) LG SUPER	Superannuation contributions	1	208.24	
DD1883.18	14/11/2017	AMP LIFE LIMITED	Superannuation contributions	1		390.64
INV SUPER	14/11/2017	AMP LIFE LIMITED	Superannuation contributions	1	390.64	
DD1883.19	14/11/2017	AMG UNIVERSAL SUPER	Superannuation contributions	1		174.54
INV SUPER	14/11/2017	AMG UNIVERSAL SUPER	Superannuation contributions	1	174.54	
DD1927.10	28/11/2017	ESSENTIAL SUPER	Superannuation contributions	1		150.75
INV SUPER	28/11/2017	ESSENTIAL SUPER	Superannuation contributions	1	150.75	

Date: 01/12/2017
Time: 9:08:54AM

Shire of Northam

USER: Kathy Scholz
PAGE: 61

Cheque / EFT No	Date	Name	Invoice Description	Bank Code	INV Amount	Amount
DD11927.11	28/11/2017	ANZ SMART CHOICE SUPER (ONEPATH MASTERFUND)	Superannuation contributions	1		204.80
INV SUPER	28/11/2017	ANZ SMART CHOICE SUPER (ONEPATH MASTERFUND)	Superannuation contributions	1	204.80	
DD11927.12	28/11/2017	HESTA SUPER FUND	Superannuation contributions	1		173.35
INV SUPER	28/11/2017	HESTA SUPER FUND	Superannuation contributions	1	173.35	
DD11927.13	28/11/2017	CBUS	Superannuation contributions	1		188.12
INV SUPER	28/11/2017	CBUS	Superannuation contributions	1	188.12	
DD11927.14	28/11/2017	AUSTRALIAN SUPER PTY LTD	Superannuation contributions	1		1,498.12
INV SUPER	28/11/2017	AUSTRALIAN SUPER PTY LTD	Superannuation contributions	1	1,498.12	
DD11927.15	28/11/2017	REST INDUSTRY SUPER	Superannuation contributions	1		744.39
INV SUPER	28/11/2017	REST INDUSTRY SUPER	Superannuation contributions	1	744.39	
DD11927.16	28/11/2017	CONCEPT ONE THE INDUSTRY SUPERANNUATION FUND	Superannuation contributions	1		302.62
INV SUPER	28/11/2017	CONCEPT ONE THE INDUSTRY SUPERANNUATION FUND	Superannuation contributions	1	302.62	
DD11927.17	28/11/2017	ZURICH AUSTRALIA LIMITED	Superannuation contributions	1		254.29
INV SUPER	28/11/2017	ZURICH AUSTRALIA LIMITED	Superannuation contributions	1	254.29	
DD11927.18	28/11/2017	IOOF PORTFOLIO SERVICE SUPERANNUATION FUND	Superannuation contributions	1		365.78
INV SUPER	28/11/2017	IOOF PORTFOLIO SERVICE SUPERANNUATION FUND	Superannuation contributions	1	365.78	
DD11927.19	28/11/2017	(THE QUEENSLAND LOCAL GOVERNMENT SUPERANNUATION BOARD) LG SUPER	Superannuation contributions	1		208.24
INV SUPER	28/11/2017	(THE QUEENSLAND LOCAL GOVERNMENT SUPERANNUATION BOARD) LG SUPER	Superannuation contributions	1	208.24	
DD11927.20	28/11/2017	AMP LIFE LIMITED	Superannuation contributions	1		390.64
INV SUPER	28/11/2017	AMP LIFE LIMITED	Superannuation contributions	1	390.64	

Date: 01/12/2017
Time: 9:08:54AM

Shire of Northam

USER: Kathy Scholz
PAGE: 62

Cheque / EFT No	Date	Name	Invoice Description	Bank Code	INV Amount	Amount
-----------------	------	------	---------------------	-----------	------------	--------

REPORT TOTALS

Bank Code	Bank Name	TOTAL
1	MUNI FUND	1,867,556.98
2	TRUST FUND	31,505.89
TOTAL		1,899,062.87

Attachment 2

Payment dates 1st November 2017 to 30th November 2017

- Municipal Fund payment cheque numbers 34836 to 34856 total \$84,996.12.
- Trust Fund payment cheque numbers 2027 to 2032 total \$614.25.

Electronic Funds Transfer

- Municipal Fund EFT28101 to EFT28436 total \$1,713,753.11.
- Trust Fund \$30,891.64.

Direct Debits total \$68,807.75.

All have been made in accordance with delegated authority reference number (M/F/F/Regs LGA 1995 S5.42):

Month	Cheques	EFT Payments	Direct Debits	Payroll	Total Payments
	2017/2018	2017/2018	2017/2018	2017/2018	2017/2018
July	\$ 145,110.71	\$2,083,341.31	\$ 59,063.47	\$ 391,344.81	\$ 2,678,860.30
August	\$ 120,443.60	\$1,945,745.15	\$ 59,266.02	\$ 367,520.50	\$ 2,492,975.27
September	\$ 92,808.84	\$ 1,797,504.44	\$ 63,419.26	\$ 377,666.43	\$ 2,331,398.97
October	\$ 115,632.21	\$ 2,241,443.48	\$ 65,410.08	\$ 384,440.60	\$ 2,806,926.37
November	\$ 85,610.37	\$1,744,644.75	\$ 68,807.75	\$ 610,482.28	\$ 2,509,545.15
December					\$ -
January					\$ -
February					\$ -
March					\$ -
April					\$ -
May					\$ -
June					\$ -
Total	\$559,605.73	\$9,812,679.13	\$315,966.58	\$2,131,454.62	\$12,819,706.06

The Following table presents all payments made for the month from Council Credit cards paid by Direct Debit 11877.1:

Summary Credit Card Payments	\$	Total
Executive Manager Engineering Services		
PUMA ENERGY SAWYERS 20/9/17	25.19	
SHIRE OF NORTHAM - REMAKE PLATE N.001	29.70	
SHIRE OF NORTHAM -NEW PLATE NUMBER 1GHX714	25.70	
LIQUOR BARONS NORTHAM - DEPOT QUARTERLY BBG	98.98	
COLES - DEPOT QUARTERLY BBG	38.28	
COLES - DEPOT QUARTERLY BBG	55.62	
WA HEALTH DEPARTMENT - POISONS PERMIT	80.00	353.47

Summary Credit Card Payments	\$	Total
CESM		
FCO MEETING	142.50	
AUSSIE NG PTY LTD - LANDFILL FIRE	52.00	
AUSSIE NG PTY LTD - LANDFILL FIRE	227.15	
PUMA ENERGY - BFB TRAINING REFRESHMENTS	154.29	
CLACKLINE STORE - TRAINING	88.00	663.94
Executive Manager Corporate Services		
FELTER HOLDINGS PTY LTD - WUNDOWIE DEPOT	19.99	19.99
Executive Manager Community Services		
CV CHECK - NATIONAL POLICE CHECK - JARED WYNNE	49.50	
SHIRE OF NORTHAM - N11131	327.35	
SHIRE OF NORTHAM - N11131	41.40	
FACEBOOK - DOWERIN FIELD DAY	30.68	
FACEBOOK - DOWERIN FIELD DAY	25.32	
INFLUENCING COMMUNITY BEHAVIORS TICKETS	70.00	
INFLUENCING COMMUNITY BEHAVIORS TICKETS	140.00	
ADOBE CREATVIE CLOUD MONTHLY CHARGES	233.16	
ROYAL LIFE SSWA - STAFF TRAINING	140.00	
ROYAL LIFE SSWA - STAFF TRAINING	280.00	
ROYAL LIFE SSWA - STAFF TRAINING	140.00	
ROYAL LIFE SSWA - STAFF TRAINING	140.00	
TELSTRA - RECHARGE INTERNET	30.00	
SUBWAY - NIGHT HOOPS	376.00	
PERTH ZOO KILLARA CONSUMABLES	288.00	
PANDA - CATERING	295.80	2,607.21
Executive Manager Development Services		
SAI GLOBAL LIMITED - RISK MANAGEMENT	251.39	
BUDGET CAR AND TRUCK - WHITE 4WD DUAL CAB - RANGER	1595.99	1,847.38
Chief Executive Officer		
SAFFRON(WA) - COFFEE WITH AVON VALLEY ADVOCATE	6.00	
ICTC SOCIETY INC - CTC MAIN STREET 2017	1386.44	
PRZCHARGE PREZI MONTHLY FEE	25.58	
CHEAPAIR.COM.AU MELB 24/10/17 JASON WHITEAKER	706.92	
CHEAPAIR.COM.AU MELB 24/10/17 CHADD HUNT	706.92	
ANNUAL FEE CARD	39.00	
FOREIGN TRANSACTION FEE	0.75	2,871.61
Total Credit Card Expenditure		\$ 8,363.60

CERTIFICATION OF THE PRESIDENT

I hereby certify that this schedule of account covering vouchers and electronic fund transfer payments as per above and totalling \$2,509,545.15 was submitted to the Ordinary Meeting of Council on Wednesday, 20 December 2017.

_____ CERTIFICATION OF THE PRESIDENT

CERTIFICATE OF THE CHIEF EXECUTIVE OFFICER

This schedule of accounts paid covering vouchers and electronic funds transfer payments as per above and totalling \$2,509,545.15 was submitted to each member of the Council on Wednesday, 20 December 2017, has been checked and is fully supported by vouchers and invoices which are submitted herewith and which have been duly certified as to the receipt of goods and the rendition of services and as to prices, computations and casting and the amounts shown are due for payment.

_____ CHIEF EXECUTIVE OFFICER



12.4.2 Financial Statements for the Period Ending 31st October 2017

Address:	N/A
Owner:	N/A
File Reference:	2.1.3.4
Reporting Officer:	Zoe Macdonald Accountant
Responsible Officer:	Colin Young Executive Manager Corporate Services
Voting Requirement	Simple Majority

BRIEF

For Council to receive the Financial Statement for the period ending 31st October 2017.

ATTACHMENTS

Attachment 1: Financial Statement for the period ending 31st October 2017.

BACKGROUND / DETAILS

The reporting of monthly financial information is a requirement under section 6.4 of the Local Government Act 1995, and Regulation 34 of the Local Government (Financial Management) Regulations.

The Statement of Financial Activity for the period ending 31st October 2017 is included as Attachment 1 to this Agenda and includes the following reports:

- Statement of Financial Activity;
- Operating Statements;
- Balance Sheet;
- Acquisition of Assets;
- Disposal of Assets;
- Information on Borrowings;
- Reserves; and
- Net Current Assets;
- Rating Information

The report includes a summary of the financial position along with comments relating to the statements. If Councillors wish to discuss the report contents or any other matters relating to this please contact Council Finance staff prior to the meeting.

Notes to the Financial Statements (Items in bold represent new notes)

Operating Income

1. Governance is over budget by \$27,364, this is directly due to a grant received from Northam Wheatbelt Development Commission for urban renewal planning that was omitted from the budget, this allocation will be accounted for in the 2017/18 Budget Review.
2. General Purpose Funding is under budget \$23,107 predominantly due to a reduction in the Federal Assistance Grant, this will be accounted for at the 2017/18 budget review.
- 3. Law, Order and Public safety is under budget by \$79,428 predominantly due to the timing of DFES, SEMC and CCTV grants.
- 4. Rec and Culture is over budget by \$418,521 due to the receipt of \$420,000 from the Department of Infrastructure and Regional Development for the 3rd milestone of the AIEC (timing).
- 5. Transport is under budget by \$56,734 due to the funding cut in the Mainroads direct grant receipt, this will be accounted for in the 2017/2018 Budget Review.
- 6. Other Property & Services over budget \$56,556 this is directly related to the receipt of insurance income for the Wundowie Pool claim of \$37,824 and Private works income from the upgrade of Byfield Street, \$4,844 received but not budgeted for

Operating Expenditure

- 7. Governance is under budget by \$162,977 due to salaries and wages of \$72,299, the timing of expenditure of Consultants \$45,483, Audit Fees \$12,498, and Office maintenance. \$6,213.
- 8. General Purpose Funding is under budget by \$17,382 due to the timing of Legal Costs recoverable of \$12,135.
- 9. Community Amenities is under budget by \$241,769 predominantly due to the timing of expenditure on the items presented below;
 - Refuse Collection of \$46,363
 - Refuse Site maintenance of \$100,971
 - Green Waste of \$8,333
 - Verge Bins of \$20,617,
 - Septage Pond maintenance of \$37,635,
 - Consultants of \$22,011
 - Town Planning Salaries of \$21,990.
- 10. Recreation and Culture is \$221,506 under budget, predominantly due to the items disclosed below;
 - Wundowie and Northam pool salaries of \$61,667
 - Wundowie and Northam pool operating expenditure of \$25,953
 - Recreation control of \$12,155
 - Public parks and gardens of \$49,342
 - Jubilee Pavilion maintenance of \$13,882

- Wundowie Oval building of \$10,428
- Public Halls of \$13,782.
- 11. Economic Services is under budget by \$124,163 due to the items presented below;
 - Festivals are under by \$12,703
 - Buildings Salaries by \$18,584
 - Main Street Heritage by \$20,406
 - Maintenance of Council Property by \$10,466
 - Reticulation by \$12,707
 - Interest repayment on the loan is timing of \$10,275
 - Visitors Centre salaries is under by \$18,815
- 12. Other Property & Services is over budget \$122,570 due predominantly to public works overhead balance costing and recovery \$34,827 and Plant over allocation of \$14,251.

Operating Income by Nature and Type

- 13. Operating Grants and subsidies is under budget by \$114,263 due to the items disclosed at points 2, 3 and 5 above.
- 15. Other revenue is over budget by \$24,158, item disclosed in point 6.

Operating Expenditure by Nature and Type

- 16. Employee Costs are under budget by 15%, \$434,723 predominantly due to timing.
- 17. Materials and contracts are under budget by 22%, due to a timing issues between budget and actual expenditure as disclosed in the notes 7 and 9 as presented above.
- 18. Other expenditure is over budget by \$112,897 due to timing of overhead recovery.

Capital Expenditure Item reporting

There were no significant items to report in October.

CONSIDERATIONS

Strategic Community / Corporate Business Plan

Theme Area 6: Governance & Leadership.

Outcome 6.3: The Shire of Northam council is a sustainable, responsive, innovative and transparent organisation.

Financial / Resource Implications

The Financial Statements have been prepared in accordance with Council's 2017/18 Budget.

Legislative Compliance

Section 6.4 and 6.26(2)(g) of the Local Government Act.

Local Government (Financial Management) Regulations 1996.

Policy Implications

Nil.

Stakeholder Engagement / Consultation

N/A.

Risk Implications

Nil.

OFFICER'S COMMENT

Nil.

RECOMMENDATION

That Council receive the Financial Statements, prepared in accordance with the Local Government (Financial Management) Regulations, for the period ending 30th October 2017.

Attachment 1



Shire of Northam

SHIRE OF NORTHAM
MONTHLY STATEMENT OF FINANCIAL ACTIVITY
FOR THE PERIOD ENDING 31 OCTOBER 2017

TABLE OF CONTENTS

	Page
Statement of Financial Activity	2
Notes to and Forming Part of the Statement	
1 Acquisition of Assets	3 to 6
2 Disposal of Assets	7 to 8
3 Information on Borrowings	9 to 10
4 Reserves	11 to 16
5 Net Current Assets	17
6 Rating Information	18 to 19
7 Trust Funds	20
8 Operating Statement	21
9 Balance Sheet	22
10 Financial Ratio	23
11 Material Variances Notes	24 to 25



**SHIRE OF NORTHAM
STATEMENT OF FINANCIAL ACTIVITY
FOR THE PERIOD ENDING 31 OCTOBER 2017**

	NOTE	17/18 Budget \$	Ytd Budget \$	Ytd Actual \$	Variances Actuals to Budget \$	Variances Actuals to Budget %
Operating						
Revenues						
Governance	1	27,558	3,720	31,084	27,364	735.58%
General Purpose Funding Other	2	2,174,578	636,514	613,408	(23,107)	(3.63%)
General Purpose Funding Rates		9,703,740	9,588,489	9,564,552	(23,937)	(0.25%)
Law, Order, Public Safety	3	536,812	166,767	87,339	(79,428)	(47.63%)
Health		56,000	10,594	7,133	(3,461)	(32.67%)
Education and Welfare		1,289,027	624,042	636,958	12,916	2.07%
Housing		40,842	13,612	13,742	130	0.96%
Community Amenities		2,618,347	1,816,534	1,772,360	(44,174)	(2.43%)
Recreation and Culture	4	6,861,744	2,158,096	2,576,617	418,521	19.39%
Transport	5	2,051,333	296,621	239,887	(56,734)	(19.13%)
Economic Services	6	551,897	191,288	167,273	(24,015)	(12.55%)
Other Property and Services		60,200	20,060	76,616	56,556	281.93%
Total Operating Revenue		25,972,078	15,526,338	15,786,967	260,630	1.66%
Expenses						
Governance	7	(1,311,641)	(546,428)	(383,451)	162,977	29.83%
General Purpose Funding	8	(260,267)	(88,353)	(70,971)	17,382	19.67%
Law, Order, Public Safety		(1,207,854)	(420,130)	(402,583)	17,547	4.18%
Health		(301,754)	(106,648)	(110,338)	(3,690)	(3.46%)
Education and Welfare		(1,396,885)	(486,371)	(422,008)	64,363	13.23%
Housing		(70,533)	(25,424)	(34,155)	(8,731)	(34.34%)
Community Amenities	9	(3,530,116)	(1,047,442)	(805,673)	241,769	23.08%
Recreation & Culture	10	(4,696,688)	(1,636,321)	(1,436,676)	199,645	12.20%
Transport		(4,926,851)	(1,817,346)	(1,815,843)	1,503	0.08%
Economic Services	11	(2,245,885)	(929,395)	(815,507)	113,888	12.25%
Other Property and Services	12	(27,089)	(96,323)	(218,893)	(122,570)	(127.25%)
Total Operating Expenses		(19,975,563)	(7,200,182)	(6,516,098)	684,084	9.50%
Removal of Non-Cash Items						
(Profit)/Loss on Asset Disposals		(80,555)	31,476	20,587	(10,889)	
Movement in Employee Benefit Provisions		(29,403)	0	0	0	
Depreciation on Assets		4,035,413	1,345,080	1,456,243	111,163	(8.26%)
Non Operating Items						
Purchase Land Held for Resale		0	0	0	0	
Purchase Land and Buildings		(5,873,402)	(2,195,348)	(1,601,666)	593,682	27.04%
Purchase Plant and Equipment		(1,302,051)	(537,728)	(169,248)	368,480	68.53%
Purchase Furniture and Equipment		(55,128)	(1,164)	0	1,164	100.00%
Purchase Bush Fire Equipment		0	0	0	0	
Purchase Playground Equipment		0	0	0	0	
Purchase Infrastructure Assets - Roads		(3,793,771)	(1,036,722)	(242,518)	794,204	76.61%
Purchase Infrastructure Assets - Bridges		0	0	0	0	
Purchase Infrastructure Assets - Footpaths		(442,344)	(147,412)	(660)	146,752	99.55%
Purchase Infrastructure Assets - Drainage		(2,277,051)	(947,872)	(849,928)	97,944	10.33%
Purchase Infrastructure Assets - Parks & Ovals		(362,595)	(120,852)	(46,613)	74,239	61.43%
Purchase Infrastructure Assets - Airfields		0	0	0	0	
Purchase Infrastructure Assets - Streetscape		(13,500)	(4,500)	0	4,500	100.00%
Purchase Infrastructure Assets - Other		(5,213,767)	(444,117)	(27,978)	416,139	93.70%
Proceeds from Disposal of Assets		732,363	244,112	18,056	(226,056)	92.60%
Repayment of Debentures		(227,611)	(111,588)	(86,465)	15,123	13.55%
Proceeds from New Debentures		1,500,000	0	0	0	
Advances to Community Groups		0	0	0	0	
Self-Supporting Loan Principal Income		24,073	8,024	2,795	(5,229)	65.17%
Transfers to Restricted Assets (Reserves)		(1,576,282)	0	(51,258)	(51,258)	
Transfers from Restricted Asset (Reserves)		2,095,126	0	0	0	
Transfers from Restricted Asset (Other)		0	0	0	0	0.00%
ADD Net Current Assets July 1 B/Fwd		6,863,970	6,863,970	6,793,607	(70,363)	
LESS Net Current Assets Year to Date		0	11,239,136	14,421,331	3,182,195	
Surplus		0	32,379	(44,587)	(76,968)	

This statement is to be read in conjunction with the accompanying notes.

SHIRE OF NORTHAM

NOTES TO AND FORMING PART OF THE STATEMENT OF FINANCIAL ACTIVITY

FOR THE PERIOD ENDING 31 OCTOBER 2017

1. OPERATING STATEMENT

	Note	17/18 Budget \$	Ytd Budget	Ytd Actual \$	Variances Actuals to Budget \$	Variances Actual to Budget %
OPERATING REVENUES						
Rates		9,704,740	9,578,072	9,577,777	(295)	0%
Operating Grants Subsidies and Contributions		4,120,264	1,347,216	1,232,953	(114,263)	-8%
Fees and Charges		3,830,578	2,238,299	2,136,926	(101,373)	-5%
Proceeds from Sale of Assets				0	0	
Service Charges		0		0	0	
Interest Earnings		370,000	173,996	166,951	(7,045)	-4%
Other Revenue		676,777	187,998	212,156	24,158	13%
TOTAL OPERATING REVENUE		18,702,359	13,525,582	13,326,762	(198,819)	-1%
OPERATING EXPENSES						
Employee Costs	16	(7,919,244)	(2,810,564)	(2,375,841)	434,723	15%
Materials and Contracts	17	(6,239,140)	(2,095,230)	(1,638,163)	457,067	22%
Utility Charges		(851,187)	(262,980)	(260,697)	2,283	1%
Depreciation of Non Current Assets		(4,035,413)	(1,345,080)	(1,456,243)	(111,163)	-8%
Interest Expenses		(148,149)	(37,269)	(36,745)	524	1%
Insurance Expenses		(471,331)	(444,201)	(442,299)	1,902	0%
Other Expenditure	18	(215,384)	(172,626)	(285,523)	(112,897)	-65%
TOTAL OPERATING EXPENSE		(19,879,848)	(7,167,950)	(6,495,511)	672,439	-9%
Non Operating Grants Subsidies and Contributions		7,093,449	2,000,000	2,460,205	460,205	-23%
Profit on Asset Disposals		177,271	756		(756)	100%
Loss on Asset Disposals		(96,716)	(32,232)	(20,587)	11,645	36%
RESULTING FROM OPERATIONS		5,996,515	8,326,156	9,270,870	944,714	11%

SHIRE OF NORTHAM

NOTES TO AND FORMING PART OF THE STATEMENT OF FINANCIAL ACTIVITY

FOR THE PERIOD ENDING 31 OCTOBER 2017

2. BALANCE SHEET

	Ytd Actual \$	Actual 2016/2017 Actual \$
CURRENT ASSETS		
Cash Assets	12,724,215	11,700,546
Receivables	7,845,831	2,441,368
Inventories	631	631
TOTAL CURRENT ASSETS	<u>20,570,677</u>	<u>14,142,545</u>
NON-CURRENT ASSETS		
Receivables	547,357	547,356
Inventories	0	0
Land and Buildings	51,347,494	50,003,006
Property, Plant and Equipment	6,191,438	5,830,177
Infrastructure	145,221,005	145,527,705
TOTAL NON-CURRENT ASSETS	<u>203,307,294</u>	<u>201,908,244</u>
TOTAL ASSETS	<u>223,877,971</u>	<u>216,050,789</u>
CURRENT LIABILITIES		
Payables	189,318	1,516,537
Interest-bearing Liabilities	128,144	224,611
Provisions	1,049,953	1,049,952
TOTAL CURRENT LIABILITIES	<u>1,347,415</u>	<u>2,791,100</u>
NON-CURRENT LIABILITIES		
Interest-bearing Liabilities	2,011,062	2,011,062
Provisions	248,832	248,832
TOTAL NON-CURRENT LIABILITIES	<u>2,259,894</u>	<u>2,259,894</u>
TOTAL LIABILITIES	<u>3,607,309</u>	<u>5,050,994</u>
NET ASSETS	<u>220,270,662</u>	<u>210,999,795</u>
EQUITY		
Retained Surplus	93,464,907	84,238,303
Reserves - Cash Backed	5,517,050	5,472,789
Reserves - Asset Revaluation	121,288,705	121,288,703
TOTAL EQUITY	<u>220,270,662</u>	<u>210,999,795</u>



SHIRE OF NORTHAM

NOTES TO AND FORMING PART OF THE STATEMENT OF FINANCIAL ACTIVITY

FOR THE PERIOD ENDING 31 OCTOBER 2017

3. ACQUISITION OF ASSETS	17/18 Budget \$	Ytd Actual \$
The following assets have been acquired during the period under review:		
By Program		
Governance		
Admin Building	337,500	0
New Telephone System	42,276	0
Intramaps GIS	9,352	0
Law, Order & Public Safety		
CESM Vehicle	89,363	0
Electronic Conversion of Standpipe	12,500	0
CCTV - Fitzgerald St & Peel Tce	91,838	3,890
Education & Welfare		
Fluffy Ducks	232,954	6,658
Killara Commuter Bus	73,539	0
Housing		
Kurringal Units Upgrade	19,000	1,750
Community Amenities		
Cemetery Toilet	53,972	0
Community Coaster Bus	120,903	0
King Creek Drainage	824,040	412,938
Area Drainage	186,669	0
Design of Recycling Station Inkpen	10,000	6,095
Inkpen Site Drainage	110,000	0
Upgrade Riverbank Fencing	30,318	2,748
Upgrade Aerators	6,000	0
NRM Grant Capital Expenditure	40,100	0
Exec Mgr Community Services Vehicle	45,000	44,675
Cemetery Lot development	28,600	0
Cemetery Car Parking	40,000	0
CBD Works - Street Scaping	75,000	0
Avon Mall Upgrade & Street Scaping	90,000	0

SHIRE OF NORTHAM

NOTES TO AND FORMING PART OF THE STATEMENT OF FINANCIAL ACTIVITY

FOR THE PERIOD ENDING 31 OCTOBER 2017

3. ACQUISITION OF ASSETS (Continued)	17/18 Budget \$	2017 Actual \$
<u>By Program (Continued)</u>		
Recreation & Culture		
Paint Eaves & Fascia Wundowie Hall	5,500	0
Replace Veranda Ceilings Wundowie Hall	2,200	0
Town Hall Render Remedial Works c/wd	98,423	30,759
Painting Window Frames Northam Town Hall	3,200	0
Painting and Patching Internal Walls Town Hall	4,200	0
External Turnstil Outdoor Courts Northam Rec Centre	7,450	0
Downlights Hospitality Area Northam Rec Centre	4,800	0
Replace Lights Stadium, Northam Rec Centre	6,000	0
Install Security Screens to Club Office Windows	5,865	4,851
Bert Hawke Pavilion - Upgrade, Including Kitchen C/wd	40,000	0
Replace Sewer Line Wundowie Library C/wd	14,300	0
Repairs to Exterior Steps Northam Library	20,000	0
Old Railway Station Precinct Upgrade C/wd	63,000	0
AVVVA - Roof Replacement	145,000	0
Northam Library Server Cabinet	3,500	0
Executive Manager Community Services Vehicle	45,000	44,675
Recreation Manager Vehicle	35,000	0
Purchase of Land Boulevard Shopping Centre	175,000	15,909
Bernard Park Bridge Refurbishment	15,000	0
Wundowie Basketball Surface Upgrade	80,000	0
Upgrade Bernard Park Reticulation	37,578	9,472
Bridge Crossing Fixings	10,000	0
POS Playground Improvements	140,017	37,141
BMX Lighting	20,000	0
Bert Hawke - Drainage	40,000	0
Bert Hawke - Lighting	20,000	0
Northam Youth Space	859,411	15,245
Swimming Pool Redevelopment	3,800,000	0

SHIRE OF NORTHAM

NOTES TO AND FORMING PART OF THE STATEMENT OF FINANCIAL ACTIVITY

FOR THE PERIOD ENDING 31 OCTOBER 2017

3. ACQUISITION OF ASSETS (Continued)	17/18 Budget \$	2017 Actual \$
<u>By Program (Continued)</u>		
Transport		
Northam Depot Redesign	10,000	0
GEH Deproclamation	55,870	0
Jennapullin Road	94,465	0
Irishtown Road	105,193	0
Irishtown Road	133,216	0
Spencers Brook Road	157,825	2,670
Spencers Brook Road	304,215	0
Maintenance Capitalised	100,000	0
GEH BS Contribution	64,500	0
Bedford Street C/fwd	109,280	1,402
Fermoy Avenue	126,133	0
Trimmer Road C/fwd	131,822	115,614
Rushton Crescent	97,130	0
Katrine Road	221,593	0
Carter Road	222,151	0
Mitchell Avenue C/fwd	96,247	48,643
Chidlow/Hawes/Burgoyne Street C/fwd	118,598	0
Newman Road - Spray Seal C/fwd	116,258	60,706
O'Neill Road C/fwd	286,229	2,748
Mount Ommanney Road C/fwd	10,600	461
Rockett Street	149,914	0
Thomas Street C/fwd	20,735	2,238
Irish Town Link Road C/fwd	0	1,470
Coates Road/ Cfw	155,317	200
Queen Street	3,000	0
Werribee Road 0.56-2.8 slk - 15/16 Blackspot C/fwd	24,889	0
Spencers Brook 1020 C/fwd	39,223	0
Spencers Brook Road	224,680	0
Kerb Renewal	134,238	6,165
Chinanning Road	80,086	200
Chedaring	323,365	0
Laneway Land Acquisition	57,000	0
Mitchell Avenue	188,782	629
Fitzgerald Street	84,127	31
Lobellia Avenue	108,882	0
Lance Street	60,553	0

SHIRE OF NORTHAM

NOTES TO AND FORMING PART OF THE STATEMENT OF FINANCIAL ACTIVITY

FOR THE PERIOD ENDING 31 OCTOBER 2017

3. ACQUISITION OF ASSETS (Continued)	17/18 Budget \$	2017 Actual \$
Drainage - Rural	1,182,104	436,991
Culvert Renewal	59,238	0
Airport Line Marking	30,000	0
Drop Down Gate Airstrip	20,000	0
PN1218 Mitsubishi Fuso	120,000	0
PN3555 Back Hoe Loader	184,835	0
PN1221 4T Truck	92,135	0
PN1302 Ferris Mower	26,950	0
PN1222 3.5T Truck	78,745	0
PN1505, 4X4 Ute	40,000	0
Posi Truck Attachment C/fwd	25,000	0
4T Excavator (drainage crew)	95,000	78,460
Grader Blade (Pozitrac)	10,800	0
Profiler Attachment (Pozitrac)	18,600	0
Single Axel Trailer Traffic Management	0	1,439
Economic Services		
AEIC Building	4,625,039	1,541,739
Waste Water Pump Station	201,181	0
Bakers Drainage	25,000	0
Upgrade Caravan Dump Site	3,500	0
Signage Tower GEH Mitchell Avenue	10,000	0
	<u>19,333,609</u>	<u>2,938,610</u>

SHIRE OF NORTHAM

NOTES TO AND FORMING PART OF THE STATEMENT OF FINANCIAL ACTIVITY

FOR THE PERIOD ENDING 31 OCTOBER 2017

3. ACQUISITION OF ASSETS (Continued)	17/18 Budget \$	2017 Actual \$
<u>By Class</u>		
Land Held for Resale	0	0
Land and Buildings	5,873,403	1,601,666
Plant and Equipment	1,302,051	169,248
Furniture and Equipment	55,128	0
Bush Fire Equipment	0	0
Playground Equipment	0	0
Infrastructure Assets - Roads	3,793,770	242,518
Infrastructure Assets - Footpaths	442,344	660
Infrastructure Assets - Bridges & Culverts	0	0
Infrastructure Assets - Drainage	2,277,051	849,928
Infrastructure Assets - Parks & Ovals	362,595	46,613
Infrastructure Assets - Airfields	0	0
Infrastructure Assets - Streetscape	13,500	-
Infrastructure Assets - Other	5,213,767	27,978
	19,333,609	2,938,610



SHIRE OF NORTHAM
NOTES TO AND FORMING PART OF THE STATEMENT OF FINANCIAL ACTIVITY
FOR THE PERIOD ENDING 31 OCTOBER 2017

4. DISPOSALS OF ASSETS

The following assets have been disposed of during the period under review:

By Program	Written Down Value		Sale Proceeds		Profit(Loss)	
	17/18 Budget \$	Ytd Actual \$	17/18 Budget \$	Ytd Actual \$	17/18 Budget \$	Ytd Actual \$
Governance						
Admin Photocopier (written off)	0	3,085	0	0	0	(3,085)
Law, Order, Public Safety						
Mitsubishi Challenger 2015	27,145		22,727		(4,418)	0
Education & Welfare						
Killara Toyota Hiace Commuter	27,061		23,000		(4,061)	0
Community Amenities						
Toyota Coaster Bus Community	51,721		45,000		(6,721)	0
Isuzu Mu-X Silver Stsdn Diesel	35,332		30,000		(5,332)	0
Recreation & Culture						
Toyota Hilux T Top 2015 white	23,491		19,000		(4,491)	0
Mitsubishi Outlander Phev 2015 Silver	33,933	34,158	25,000	17,273	(8,933)	(16,885)
Sale of Land Boulevard Shopping Centre	175,000		350,000		175,000	0
Transport						
Mitsubishi Fuso	43,000		45,000		2,000	0
Back Hoe Loader 2008	80,142		50,000		(30,142)	0
Hino 500 Series 4T	61,410		45,000		(16,410)	0
Ferris Mower	10,775		5,500		(5,275)	0
Hino 300 Series 3.5T	42,729		43,000		271	0
Ferris Mower	10,775		5,500		(5,275)	0
Bobcat Trailer 4T	0	1,400	0	783	0	(617)
Ford Ranger Ute XI 4X4 2015	29,294		23,636		(5,658)	0
	651,808	38,643	732,363	18,056	80,555	(20,587)



SHIRE OF NORTHAM
NOTES TO AND FORMING PART OF THE STATEMENT OF FINANCIAL ACTIVITY
FOR THE PERIOD ENDING 31 OCTOBER 2017

4. DISPOSALS OF ASSETS

The following assets have been disposed of during the period under review:

<u>By Class</u>	Written Down Value		Sale Proceeds		Profit(Loss)	
	17/18 Budget \$	Ytd Actual \$	17/18 Budget \$	Ytd Actual \$	17/18 Budget \$	Ytd Actual \$
Land & Buildings						
Sale of Land Tfr to community recreation & Facilities Reserve	175,000	0	350,000	0	175,000	0
Plant & Equipment						
Admin Photocopier (written off)		3,085		0		(3,085)
Mitsubishi Challenger 2015	27,145	0	22,727	0	(4,418)	0
Killara Toyota Hiace Commuter	27,061	0	23,000	0	(4,061)	0
Toyota Coaster Bus Community	51,721	0	45,000	0	(6,721)	0
Isuzu Mu-X Silver Stsdn Diesel	35,332	0	30,000	0	(5,332)	0
Toyota Hilux T Top 2015 white	23,491	0	19,000	0	(4,491)	0
Mitsubishi Outlander Phev 2015 Silver	33,933	34,158	25,000	17,273	(8,933)	(16,885)
Mitsubishi Fuso	43,000	0	45,000	0	2,000	0
Back Hoe Loader 2008	80,142	0	50,000	0	(30,142)	0
Hino 500 Series 4T	61,410	0	45,000	0	(16,410)	0
Ferris Mower	10,775	0	5,500	0	(5,275)	0
Hino 300 Series 3.5T	42,729	0	43,000	0	271	0
Ferris Mower	10,775	0	5,500	0	(5,275)	0
Bobcat Trailer 4T	0	1,400	0	783	0	(617)
Ford Ranger Ute XI 4X4 2015	29,294	0	23,636	0	(5,658)	0
	651,808	38,643	732,363	18,056	80,555	(20,587)
					17/18 Budget \$	Ytd Actual \$
Summary						
Profit on Asset Disposals						
Loss on Asset Disposals						(20,587)
					0	(20,587)



SHIRE OF NORTHAM

NOTES TO AND FORMING PART OF THE STATEMENT OF FINANCIAL ACTIVITY

FOR THE PERIOD ENDING 31 OCTOBER 2017

5 INFORMATION ON BORROWINGS

(a) Debenture Repayments

Particulars	Principal 1-Jul-17	New Loans		Principal Repayments		Principal Outstanding		Interest Repayments	
		17/18 Budget \$	Ytd Actual \$	17/18 Budget \$	Ytd Actual \$	17/18 Budget \$	Ytd Actual \$	17/18 Budget \$	Ytd Actual \$
Recreation & Culture									
Loan 208 - Northam Country Club **	7.36%	15,059	0	5,695	2,795	9,364	12,264	1,092	309
Loan 219A - Northam Bowling Club **	3.18%	200,386	0	18,378	0	182,007	200,386	7,503	(453)
Loan 223 - Recreation Facilities	6.06%	367,975	0	115,413	56,844	252,562	311,131	22,920	1,848
Loan 224 - Recreation Facilities	6.48%	901,436	0	41,165	20,254	860,271	881,182	63,740	19,311
Loan New - Swimming Pool		0	1,000,000	0	0	1,000,000	0	0	0
Loan New - Youth Space		0	500,000	0	0	500,000	0	0	0
Transport									
Loan 221 - Airstrip Upgrade	6.22%	13,280	0	13,280	0	0	13,280	743	(70)
Economic Services									
Loan 225 - Victoria Oval Purchase	6.48%	737,539	0	33,680	16,572	703,858	720,967	52,151	15,800
		2,235,675	1,500,000	227,611	96,465	3,508,063	2,139,210	148,149	36,745

Note: ** indicates self - supporting loans

All other debenture repayments are to be financed by general purpose revenue.

Loan 221 - No longer a self supporting loan to Northam Aero Club now financed by general purpose revenue.



SHIRE OF NORTHAM

NOTES TO AND FORMING PART OF THE STATEMENT OF FINANCIAL ACTIVITY

FOR THE PERIOD ENDING 31 OCTOBER 2017

	17/18 Budget				Ytd Actual					
	Opening Bal	Interest	Tfr To Reserve	Tfr From Reserve	Total	Opening Bal	Interest	Tfr To Reserve	Tfr From Reserve	Total
6. RESERVES - CASH BACKED										
Aged Accommodation Reserve	224,877	4,958	5,000	(19,000)	215,835	216,265	2,118			218,383
Employee Liability Reserve	453,025	9,988	-	-	463,013	469,890	4,266			474,156
Housing Reserve	252,463	6,566	-	-	258,029	248,079	2,315			250,459
Reticulation Scheme Reserve	57,515	1,268	10,000	-	68,783	89,815	541			90,357
Office Equipment Reserve	96,818	2,135	-	(42,276)	56,677	125,130	1,479			126,609
Plant & Equipment Reserve	282,150	6,221	365,000	(424,400)	228,971	524,607	2,570			527,277
Recreation Reserve					-	-				-
Road & Bridgeworks Reserve	53,549	1,401	10,000	-	74,950	99,675	620			100,295
Refuse Site Reserve	352,842	7,779	114,662	-	475,283	363,859	3,315			367,174
Regional Development Reserve	85,149	1,877	-	(80,000)	7,026	892,704	838			893,542
Speedway Reserve	140,349	3,094	-	-	143,443	137,911	1,321			139,232
Community Bus Replacement Reserve	52,381	1,155	10,000	(62,000)	1,536	31,817	492			32,309
Septage Pond Reserve	310,701	6,850	-	(45,000)	272,551	357,491	2,925			360,416
Killara Reserve	235,896	5,201	44,000	(50,539)	234,558	149,297	2,217			151,514
Stormwater Drainage Projects Reserve	28,536	629	100,000	-	129,165	28,040	269			28,309
Recreation and Community Facilities Reserve	1,579,933	34,834	382,210	(979,411)	1,017,566	772,149	14,836			786,985
Administration Office Reserve	673,723	14,854	-	(337,500)	351,077	652,257	5,774			668,031
Council Buildings & Amenities Reserve	8,149	180	341,785	-	350,114	33,038	82			33,120
River Town Pool Dredging Reserve	294,999	6,505	-	-	301,504	289,875	2,776			292,651
Parking Facilities Construction Reserve	192,597	4,247	53,625	(40,000)	210,469	120,488	1,810			122,298
Art Collection Reserve	22,065	486	-	-	22,551	21,682	208			21,890
Election Reserve	15,001	331	-	(15,000)	332		141			141
Revaluation Reserve	20,002	441	20,000	-	40,443		187			187
Total Cash Backed Reserves	5,442,720	120,000	1,456,282	(2,095,126)	4,923,876	5,634,070	51,260			5,685,330
Total Interest				1,576,292			51,260			

All of the above reserve accounts are to be supported by money held in financial institutions.



SHIRE OF NORTHAM

NOTES TO AND FORMING PART OF THE STATEMENT OF FINANCIAL ACTIVITY

FOR THE PERIOD ENDING 31 OCTOBER 2017

	17/18 Budget	Ytd Actual	Actual 2016/2017 Financial Report
	\$	\$	\$
7. NET CURRENT ASSETS			
Composition of Estimated Net Current Asset Position			
CURRENT ASSETS			
Cash - Unrestricted	200,000	6,149,233	4,102,486
Cash - Restricted Unspent Grants	0	1,070,751	2,125,271
Cash - Restricted Reserves	4,923,876	5,524,050	5,472,790
Self Supporting Loan		12,304	15,099
Sundry Debtors	2,170,316	2,513,417	478,800
Rates - Current	0	5,425,878	1,890,598
Pensioners Rates Rebate	0	15,904	0
Provision for Doubtful Debts	0	(151,505)	(151,505)
GST Receivable	0	0	178,542
Accrued Income/Prepayments	0	29,834	29,834
Inventories	10,000	631	631
	<u>7,304,192</u>	<u>20,590,497</u>	<u>14,142,545</u>
LESS: CURRENT LIABILITIES			
Sundry Creditors	(3,320,940)	(455,117)	(1,224,306)
Rates Income in Advance	0	145,744	(2,944)
GST Payable	0	0	0
Accrued Salaries & Wages	0	0	(63,173)
Accrued Interest on Debentures	0	240	(35,666)
Payroll Creditors	0	0	0
Accrued Expenditure	0	0	(190,449)
Withholding Tax Payable	0	0	0
Payg Payable	0	139,814	0
Loan Liability	0	(128,144)	(224,611)
Provision for Annual Leave	0	(563,236)	(563,236)
Provision for Long Service Leave	0	(486,716)	(486,716)
Other Payables	0	0	0
	<u>(3,320,940)</u>	<u>(1,347,416)</u>	<u>(2,791,101)</u>
NET CURRENT ASSET POSITION	3,983,252	19,243,081	11,351,444
Less: Cash - Reserves - Restricted	(4,923,876)	(5,524,050)	(5,472,790)
Less: Cash - Unspent Grants - Restricted	0	0	0
Less: Land for resale - Cost of acquisition			0
Less: Loans receivable - clubs/institutions			(15,099)
Add: Current Loan Liability	227,611	128,144	224,611
Add: Leave Liability Reserve	463,013	474,156	455,441
Add: Budgeted Leave	250,000	100,000	250,000
ESTIMATED SURPLUS/(DEFICIENCY) C/FWD	0	14,421,331	6,793,607

SHIRE OF NORTHAM
RATING REPORT
FOR THE PERIOD ENDED 31 OCTOBER 2017

	2009/10	2010/11	2011/12	2012/13	2013/14	2014/15	2015/16	2016/17	2017/18
Key Rating Dates									
RATES ISSUED	28/07/09	04/08/10	08/08/2011	5/08/2012	4/09/2013	14/08/14	14/08/15		1/08/2017
RATES DUE	9/09/2009	13/09/2010	22/09/2011	24/09/2012	23/10/2013	8/10/2014	25/09/2015	30/09/2016	14/09/2017
2nd INSTALMENT DUE	9/11/2009	12/11/2010	22/11/2011	16/11/2012	23/12/2013	8/12/2014	25/11/2015	30/11/2016	14/11/2017
3rd INSTALMENT DUE	11/01/2010	11/01/2011	23/01/2012	29/01/2013	24/02/2014	9/02/2015	25/01/2016	30/01/2017	15/01/2018
4th INSTALMENT DUE	11/03/2010	14/03/2011	22/03/2012	29/03/2013	24/04/2014	9/04/2015	28/03/2016	30/03/2017	15/03/2018
Outstanding 1st July	\$405,172	\$540,290	\$521,194	\$562,531	\$688,647	\$718,120	\$873,688	\$1,116,220	\$1,492,068.00
Rates Levied	\$5,879,217	\$6,268,889	\$6,851,706	\$7,312,029	\$7,758,147	\$8,222,618	\$8,552,189	\$8,931,257	\$9,564,551.00
Interest, Ex gratia	\$52,427	\$75,632	\$63,079	\$68,857	\$73,630	\$80,154	\$83,173	\$91,384	\$70,615.44
Rates Paid by month									
1 July	48,247	24,586	51,948	38,805	47,443	62,554	29,105	43,333	59,120
2 August	1,402,457	1,272,790	1,120,912	1,043,163	23,961	119,840	700,198	367,776	1,897,693
3 September	2,241,533	2,736,315	3,251,815	3,604,324	1,152,418	2,650,420	4,519,842	4,243,288	3,585,868
4 October	627,550	374,463	318,701	443,703	3,790,646	2,550,091	630,888	1,166,136	481,840
5 November	494,773	600,065	689,461	680,522	444,497	508,022	842,856	908,844	
6 December	179,425	158,023	172,178	160,865	685,338	654,900	214,507	336,154	
7 January	333,075	362,368	441,740	469,219	194,157	295,629	441,681	464,526	
8 February	101,317	99,165	112,296	166,351	502,176	508,828	148,327	260,963	
9 March	304,264	404,575	438,277	448,126	178,270	256,379	601,416	589,684	
10 April	60,140	202,155	105,463	261,010	517,451	484,165	166,567	182,282	
11 May	26,615	162,815	101,999	119,726	110,851	87,473	102,660	91,433	
12 June	69,843	88,639	87,525	30,530	120,455	59,527	115,947	109,069	
Total YTD	4,319,788	4,408,154	4,743,376	5,129,995	5,014,466	5,382,905	5,880,032	5,820,532	6,014,520
% Rates Outstanding	31.8%	36.0%	36.2%	35.4%	40.3%	40.3%	38.2%	42.6%	45.9%
	2,017,029	2,476,658	2,692,604	2,813,423	3,385,958	3,635,984	3,629,015	4,318,330	5,112,714

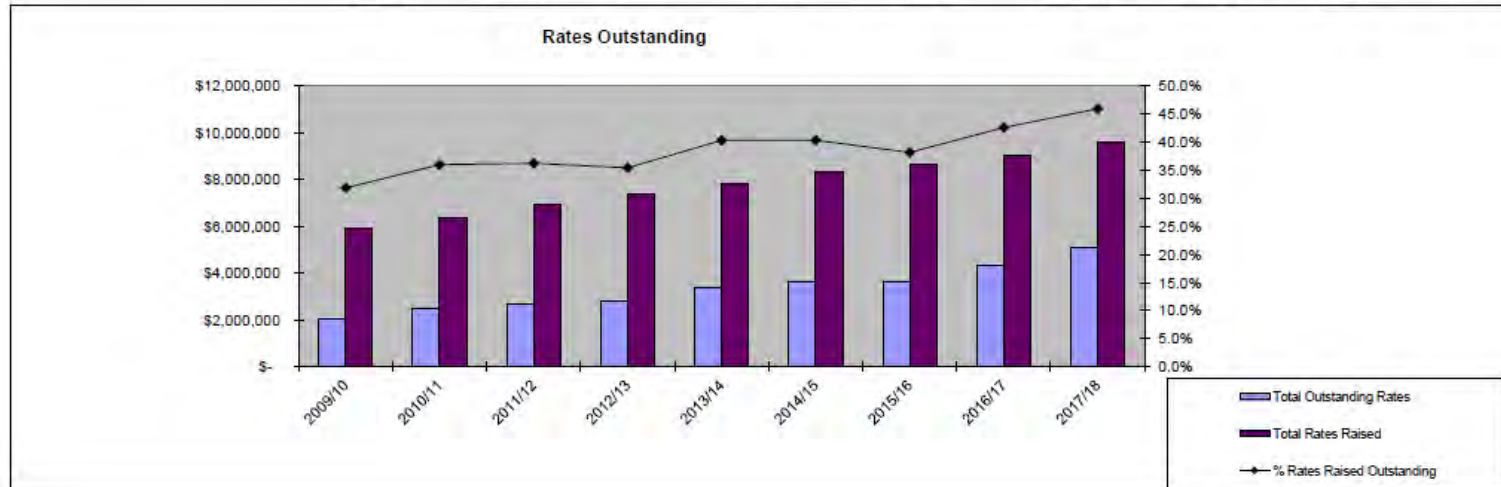

12.4.3 Operation of Waste Disposal Facilities Local Law 2008

Address:	N/A
Owner:	Shire of Northam
File Reference:	2.3.2.6
Reporting Officer:	Cheryl Greenough Coordinator Governance and Administration
Responsible Officer:	Chadd Hunt Executive Manager Development Services
Voting Requirement	Simple Majority

BRIEF

To seek Council approval to close the review process pursuant to section 3.16 of the *Local Government Act 1995* (the Act).

ATTACHMENTS

Attachment 1: Gazetted Operation of Waste Disposal Facilities 2008 Local Law.

BACKGROUND / DETAILS

The Shire of Northam Operation of Waste Disposal Facilities Local Law 2008 was Gazetted on 16th September 2008.

At the Ordinary Council meeting 16th November 2016, Council put forward a motion to commence the first stage of reviewing all of the 2008 local laws. Following on from that motion, a consultation period of six (6) weeks was held from 12th April 2017 until 2nd June 2017.

No comments were received from the community during the review process. Officers conducted a workshop to discuss any preliminary changes they have deemed as prudent. The statutory review process of the Shire's Operation of Waste Disposal Facilities Local Law 2008 in accordance with s.3.16 of the Act is now closed.

The staff have advised there are no changes required to the Operation of Waste Disposal Facilities Local Law 2008 therefore unless Council wishes to make changes to the local law, it is not necessary to commence Section 3.12 of the Act.

The table below portrays the Shire of Northam's Operation of Waste Disposal Facilities Local law 2008 stopping at this junction.

2008 Local Laws	Stage 1	s3.16	Council adopted to review Local Law & advertise for 6 weeks	Stage 2	s3.12	Council adopts to make changes to the local law and advertise changes	Stage 3	Council adopt the new local law, advertise & send for Gazettal
Dogs Local Law 2008								Lay on Table at November meeting
Cemeteries Local law 2008								Adopted at November meeting
Activities on Thoroughfares								
Extractive Industries								
Standing Orders								
Operation of Waste Facilities						No amendments required		
Parking and Parking Facilities								
Health Local Law 2008								
Keeping Control of cats								
Local Government Property								

CONSIDERATIONS

Strategic Community / Corporate Business Plan

Theme Area 4: Environment & Heritage.

Outcome 4.3: Residents and organisations within the Shire of Northam are supported to reduce their environmental impact.

- Increase energy efficiency in Shire-controlled buildings and increased procurement of renewable energy; and
- Sustainable waste management with the aim of reducing and reusing waste effectively.

Theme Area 6: Governance & Leadership.

Outcome 6.3: The Shire of Northam council is a sustainable, responsive, innovative and transparent organisation.

- Implement systems and processes which deliver quality outcomes for our community;
- Maintain a high standard of corporate governance;
- Encourage active community participation in our local government; and

- Undertake our regulatory roles in a safe, open, accountable and respectful manner.

Financial / Resource Implications

It will not be necessary to advertise unless Council make changes to the local law.

Legislative Compliance

Section 3.12 of the *Local Government Act 1995* which outline the procedures for making local laws.

Policy Implications

Nil.

Stakeholder Engagement / Consultation

No further consultation is required unless Council make changes to the local law.

Risk Implications

Nil.

OFFICER'S COMMENT

The Operation of Waste Disposal Facilities Local Law 2008 does not require repealing or amending and therefore remains at the status quo until the next review is required to be undertaken or some matters change which require amendment.

RECOMMENDATION

That Council accept this report as confirmation that the Operation of Waste Disposal Facilities Local Law 2008 does not require repealing or amending at this time.

Attachment 1

16 September 2008

GOVERNMENT GAZETTE, WA

4269

LOCAL GOVERNMENT ACT 1995

SHIRE OF NORTHAM

OPERATION OF WASTE DISPOSAL FACILITIES LOCAL LAW 2008

Under the powers conferred by the *Local Government Act 1995* and of all the powers enabling it, the Council of the Shire of Northam hereby records having resolved on the 23rd July 2008 to make the following local law.

1 This local law may be cited as the *Shire of Northam Operation of Waste Disposal Facilities Local Law 2008*.

2 In this local law, unless the context otherwise require—

“**Act**” means the *Local Government Act 1995*;

“**authorised person**” means a person authorised by the local government to carry out duties and functions at or in respect of the facility;

“**CEO**” means the Chief Executive Officer of the Shire of Northam;

“**Council**” means the Council of the Shire of Northam;

“**facility**” means the property and buildings at the Old Quarry Road Waste Disposal Facility, the Inkpen Road Waste Disposal Facility and any other Shire operated Waste Disposal Facility used for the disposal, treatment and recycling of waste material;

“**fauna**” and “**flora**” have the meaning given to them in Section 6 of the *Wildlife Conservation Act 1950*.

“**local government**” means the Shire of Northam;

“**sewage**” means any kind of sewage, nightsoil, faecal matter or urine, and any waste composed wholly or in part of liquid;

“**toxic, poisonous or prohibited waste**” means and includes all items listed under Schedule 1 of the *Environmental Protection (Controlled Waste) Regulations 2004*; and

“**Waste**” means all manner of material discarded as being no longer required by the person owning or in possession of that material.

3. The *Town of Northam By-laws Relating to the Operation of the Colebatch Road Northam Waste Disposal Facility* as published in the *Government Gazette* on 30 April 1993 are repealed.

4. All persons using or entering upon a facility shall be subject to the provisions of this local law.

5. The drivers of all vehicles entering a facility shall observe the speed limits as depicted on standard signs erected in proximity to the access roadways.

6. All persons using or entering a facility shall act in accordance with any lawful instruction given by an authorised person.

7. In the event of a person contravening any clause of this local law or failing to obey the instructions of an authorised person then, and in addition to any penalty imposed by this local law, an authorised person may request the person to leave the facility and failure to do so shall constitute a contravention of this local law.

8. No person shall place or dispose of waste at a facility other than at a place designated by notice or by an instruction of an authorised person.

9. No person shall remove or carry away from a facility any waste unless authorised to do so by an authorised person.

10. No person shall damage, deface or otherwise cause a loss in value in any building, sign, plant and equipment of the local government situated on a facility.

11. No person shall light any fire within the precincts of a facility unless so authorised by an authorised person for purposes of protection or lessening of a fire hazard.

12. No person shall dig up, remove or otherwise damage native flora and growth at a facility unless so authorised by an authorised person.

13. No person shall trap, chase, worry or otherwise injure or maim any native fauna at a facility unless so authorised by an authorised person.

14. The local government may from time to time set and amend the hours of operation of a facility and such hours will be displayed for public information.

4270

GOVERNMENT GAZETTE, WA

16 September 2008

15. The local government may, under and in accordance with sections 6.16 to 6.19 of the Act, from time to time set and amend a scale of fees and charges payable for admission to dispose of or dump waste at a facility and such scale may specify classes and differing classes to which differing fees and charges shall apply.

16. No person shall enter a facility to dispose of or dump waste without paying the appropriate admission fee or charge except in those circumstances where so authorised by the local government.

17. It shall be an offence for any person to enter upon a facility and dump any sewage or waste without paying the appropriate charge.

18. No person shall dispose of or dump at a facility any sewage, toxic, poisonous or prohibited waste that does not comply with the facility operating licence or registration.

19. No person shall dispose of or dump at a facility tyres of any kind, except for the purpose of recycling.

20. Any person who contravenes or fails to comply with any clause of this local law commits an offence and is liable on conviction to a maximum penalty of five thousand dollars (\$5,000.00).

Dated this 23rd July 2008.

The Common Seal of the Shire of Northam was affixed by the authority of a resolution of the Council in the presence of—

Cr S. B. POLLARD, Shire President.

G. BRENNAN, Acting Chief Executive Officer.

12.4.4 Parking and Parking Facilities Amendment Local Law 2017

Address:	N/A
Owner:	Shire of Northam
File Reference:	2.3.2.6
Reporting Officer:	Cheryl Greenough Coordinator Governance and Administration
Responsible Officer:	Chadd Hunt Executive Manager Development Services
Voting Requirement	Simple Majority

BRIEF

To seek Council approval, to close the review process pursuant to section 3.16 of the *Local Government Act 1995* (the Act) and to initiate the process of amending or repealing the Shire of Northam Parking and Parking Facilities Local Law 2008 pursuant to section 3.12 of the Act.

ATTACHMENTS

Attachment 1: Shire of Northam Parking and Parking Facilities Local Law 2017 (marked up version).

BACKGROUND / DETAILS

The Parking and Parking Facilities Local Law 2008 was Gazetted on 16 September 2008.

At the Ordinary Council meeting held on 16th November 2016, Council put forward a motion to commence the first stage of reviewing all of the 2008 local laws. Following on from that motion, a consultation period of six (6) weeks was held from 12th April 2017 until 2nd June 2017.

On 12th April 2017 during the statutory review process, the Department of Local Government, Sport and Cultural Industries (formerly Department of Local Government and Communities) advised their recommendations for minor amendments to this Local Law.

No comments were received from the community during the review process and as such the Shire staff conducted a workshop to discuss the changes that were provided by the Department and any other changes they have deemed as necessary. The statutory review of the Shire's Parking and Parking Facilities Local Law 2008 in accordance with s.3.16 of the Act has now been finalised.

The following table outlines what stage of the process this local law is currently at:

2008 Local Laws	Stage 1	s3.16	Council adopted to review Local Law & advertise for 6 weeks	Stage 2	s3.12	Council adopts to either make changes to the local law and advertise the changes or repeal	Stage 3	Council adopt the new local law, advertise & send for Gazettal
Dogs Local Law 2008								Lay on Table at November meeting
Cemeteries Local law 2008								Accepted at November meeting
Activities on Thoroughfares								
Extractive Industries								
Standing Orders								
Operation of Waste Facilities								
Parking and Parking Facilities								
Health Local Law 2008								
Keeping Control of cats								
Local Government Property								

CONSIDERATIONS

Strategic Community / Corporate Business Plan

Theme Area 6: Governance & Leadership.

Outcome 6.3: The Shire of Northam council is a sustainable, responsive, innovative and transparent organisation.

- Implement systems and processes which deliver quality outcomes for our community;
- Maintain a high standard of corporate governance;
- Encourage active community participation in our local government; and
- Undertake our regulatory roles in a safe, open, accountable and respectful manner.

Financial / Resource Implications

Commencing an amendment local law process will incur:

- Advertising costs in the West Australian - Approximate cost \$400
- Advertising in the Avon Advocate relating to the adoption of the amendment local law. Approximate cost \$200

Legislative Compliance

Section 3.12 of the Local Government Act 1995 which outline the procedures for making local laws.

- (1) *In making a local law a local government is to follow the procedure described in this section, in the sequence in which it is described.*
- (2A) *Despite subsection (1), a failure to follow the procedure described in this section does not invalidate a local law if there has been substantial compliance with the procedure.*
- (2) *At a council meeting the person presiding is to give notice to the meeting of the purpose and effect of the proposed local law in the prescribed manner.*
- (3) *The local government is to —*
 - (a) *give Statewide public notice stating that —*
 - (i) *the local government proposes to make a local law the purpose and effect of which is summarized in the notice; and*
 - (ii) *a copy of the proposed local law may be inspected or obtained at any place specified in the notice; and*
 - (iii) *submissions about the proposed local law may be made to the local government before a day to be specified in the notice, being a day that is not less than 6 weeks after the notice is given; and*
 - (b) *as soon as the notice is given, give a copy of the proposed local law and a copy of the notice to the Minister and, if another Minister administers the Act under which the local law is proposed to be made, to that other Minister; and*
 - (c) *provide a copy of the proposed local law, in accordance with the notice, to any person requesting it.*
- (3a) *A notice under subsection (3) is also to be published and exhibited as if it were a local public notice.*
- (4) *After the last day for submissions, the local government is to consider any submissions made and may make the local law* as proposed or make a local law* that is not significantly different from what was proposed.*

**Absolute majority required.*

- (5) *After making the local law, the local government is to publish it in the Gazette and give a copy of it to the Minister and, if*

- another Minister administers the Act under which the local law is proposed to be made, to that other Minister.*
- (6) *After the local law has been published in the Gazette the local government is to give local public notice —*
- (a) stating the title of the local law; and*
 - (b) summarizing the purpose and effect of the local law (specifying the day on which it comes into operation); and*
 - (c) advising that copies of the local law may be inspected or **obtained from the local government's office.***
- (7) *The Minister may give directions to local governments requiring them to provide to the Parliament copies of local laws they have made and any explanatory or other material relating to them.*

Policy Implications
Nil.

Stakeholder Engagement / Consultation

Statewide and local notification in the newspaper providing 6 weeks for community consultation, public notices seeking comment were also displayed the Shire's administration centre and libraries.

Risk Implications

Potential breach of legislation.

OFFICER'S COMMENT

It should be noted that the issues that have been identified during the review process, whilst included in the report for consideration as a possible amendment to the respective local law, have not been formally assessed. This will form part of the second phase of the amendment or repeal process to this local law or during the making of new local law.

The next stage that must be conducted is outlined in Section 3.12 of the Act which prescribes the statutory procedures for making an amendment or repealing a local law and requires the following procedure to be undertaken.

To enable clear decision making, a table has been created showing all the insertions, deletions and alterations to the local law raised by the Department and Shire staff during the workshop.

The officer's recommendation at the 19 July 2017 Ordinary Council meeting advised that the Parking and Parking Facilities Local Law 2008 would be amended and presented to Council for endorsement. Below are the amendments that have been recommended by staff and the Department. Staff consider it would be best to repeal the document and commence a new local law.

Changes	Comments
The word 'Authorized' has been changed to 'Authorised' throughout the document. 28 times	To give the document the Australian spelling
The word 'motor cycle' has been changed to 'motorcycle'	To give the document the Australian spelling
'Bold' was taken off the definitions	Only headings to be 'bold'
Inserted definition: 'unattended', in relation to a vehicle, means that the driver has left the vehicle so that the driver is more than 3 metres from the closest point of the vehicle.	The definition was removed from clause 5.1
In definitions : Australian Standard 1742.11-1999 was changed to 1742.11-2016	Updated to the Latest Australian Standard
Clause 1.4 Capitals removed from Particular Definitions	To keep in line with other headings
Clause 1.4 the year 1974 was added to the <i>Road traffic Act</i> and Italics	To give the Act the correct name
Clause 4.4 Deleted title 'When angle parking applies' and inserted 'Angle Parking'	To make more sense.
Clause 4.4(1) Deleted the words 'This Clause' does not apply and changed to 'Angle parking does not apply	To make more sense
Clause 4.4(1) Deleted the letter (a) for subclause (a)	
Clause 4.4.(1)(b) Deleted sub clause (b) 'a person parking either a motor cycle without a trailer or a bicycle'	For clarity
Clause 4.5(j) Deleted the word 'Pillar Box' and replaced with the word 'public letter box'	Updated word usage
Clause 5.1 removed the definition: 'unattended', in relation to a vehicle, means that the driver has left the vehicle so that the driver is more than 3 metres from the closest point of the vehicle.'	Placed into Definitions
Clause 5.1(3) removed a subheading 'No stopping on a carriageway with yellow edge lines and placed as sub clause (3)	For clarity
Clause 7.9 removed the brackets from (other than a bicycle)	
Schedule 2 Inserted the words (Clause 9.1)	To identify offences and penalties clause
Schedule 2 number 80 (7.15) Inserted the words 'Unauthorised vehicle'	For clarity
Schedule 2 number 80 (7.15) Increased the modified penalty from \$120 to \$200	Better reflects the severity of the breach

Considerations

Previously the 2008 local law received amendments in 2009. It is possible to continue making amendments to the 2008 local law rather than repealing it and is not as costly. The potential cost for amendment would be \$440 for Gazettal, and to repeal and make a new local law could cost in excess of \$3,000.

In accordance with the provisions of the Act it is necessary to initiate the amendment/repeal process which requires the Shire to give State wide public notice providing for public inspection. This also includes displaying copies of the amendments or new local law at the Shire office and both of the Shire's Libraries.

A copy of the proposed local law, this report and a copy of the public notice advertisements, will be provided to the Minister for Local Government Sport and Cultural Industries for further review.

At the expiry of the comment period (minimum of six weeks) all submissions will be reported back to Council prior to the amendment or new local law being considered for adoption.

RECOMMENDATION

That Council:

1. Pursuant to section 3.12 of the *Local Government Act 1995* authorise the CEO to give Statewide public notice that the Shire intends to repeal the Shire of Northam Parking and Parking Facilities Local Law 2008 and make a new Shire of Northam Parking and Parking Facilities Local Law 2017 with the purpose and effect of this local law being as follows:

Purpose: The Shire Northam Parking and Parking Facilities Local Law 2017 provides for the orderly management of parking and future parking facilities within the Shire of Northam.

Effect: Inserts additional definitions and deletes some definitions to enhance operation of the Local Law and clarifies the drafting and operation of some clauses.

2. Request the CEO complete the local law process inviting public submissions on the proposal as described in s3.12(3) of the *Local Government Act 1995*.

Attachment 1

LOCAL GOVERNMENT ACT 1995

SHIRE OF NORTHAM

**PARKING AND PARKING FACILITIES
LOCAL LAW 2008**

LOCAL GOVERNMENT ACT 1995
SHIRE OF NORTHAM
PARKING AND PARKING FACILITIES LOCAL LAW 2008

TABLE OF CONTENTS

Part 1 – Definitions and Operations

- 1.1 Citation
- 1.2 Definitions
- 1.3 Repeal
- 1.4 Application of particular definitions
- 1.5 Application and pre-existing signs
- 1.6 Classes of vehicles
- 1.7 Part of thoroughfare to which sign applies
- 1.8 Powers of local government

Part 2 – Metered Zones

- 2.1 Determination of metered zones
- 2.2 Parking fee to be paid
- 2.3 Limitation on parking in metered space
- 2.4 No parking when meter is expired
- 2.5 Suspension of requirement to pay fee
- 2.6 Vehicles to be within metered space
- 2.7 Permitted insertions in parking meters
- 2.8 Parking ticket to be clearly visible
- 2.9 One vehicle per metered space
- 2.10 No parking when hood on meter

Part 3 – Parking Stalls and Parking Stations

- 3.1 Determination of parking stalls and parking stations
- 3.2 Vehicles to be within parking stall on thoroughfare
- 3.3 Payment of fee to park in parking station
- 3.4 Suspension of parking station restrictions
- 3.5 Vehicle not to be removed until fee paid
- 3.6 Entitlement to receipt
- 3.7 Parking ticket to be clearly visible
- 3.8 Parking prohibitions and restrictions

Part 4 – Parking Generally

- 4.1 Restrictions on parking in particular areas
- 4.2 Parking vehicle on a carmageway
- 4.3 When parallel and right-angled parking apply
- 4.4 When angle parking applies
- 4.5 General prohibitions on parking
- 4.6 Authorised person may order vehicle on thoroughfare to be moved
- 4.7 Authorised person may mark tyres
- 4.8 No movement of vehicles to avoid time limitation
- 4.9 No parking of vehicles exposed for sale and in other circumstances
- 4.10 Parking on private land

- 4.11 Parking on reserves
- 4.12 Suspension of parking limitations for urgent, essential or official duties

Part 5 – Parking and Stopping Generally

- 5.1 No stopping and no parking signs, and yellow edge lines

Part 6 – Stopping in Zones for Particular Vehicles

- 6.1 Stopping in a loading zone
- 6.2 Stopping in a taxi zone or a bus zone
- 6.3 Stopping in a mail zone
- 6.4 Other limitations in zones

Part 7 – Other Places Where Stopping is Restricted

- 7.1 Stopping in a shared zone
- 7.2 Double parking
- 7.3 Stopping near an obstruction
- 7.4 Stopping on a bridge or in a tunnel, etc
- 7.5 Stopping on crests, curves, etc
- 7.6 Stopping near a fire hydrant, etc
- 7.7 Stopping at or near a bus stop
- 7.8 Stopping on a path, median strip, or traffic island
- 7.9 Stopping on verge
- 7.10 Obstructing access to and from a path, driveway, etc
- 7.11 Stopping near a letter box
- 7.12 Stopping on a carriageway – heavy and long vehicles
- 7.13 Stopping on a carriageway with a bicycle parking sign
- 7.14 Stopping on a carriageway with ~~motorcycle~~ parking sign
- 7.15 Stopping in a parking stall for people with disabilities

Deleted: motor cycle

Part 8 – Miscellaneous

- 8.1 Removal of notices on vehicle
- 8.2 Unauthorised signs and defacing of signs
- 8.3 Signs must be complied with
- 8.4 General provisions about signs
- 8.5 Special purpose and emergency vehicles
- 8.6 Vehicles not to obstruct a public place

Part 9 – Penalties

- 9.1 Offences and penalties
- 9.2 Form of notices

- Schedule 1 - Parking Region
- Schedule 2 - Prescribed Offences
- Schedule 3 - Deemed Parking Stations

LOCAL GOVERNMENT ACT 1995

SHIRE OF NORTHAM

PARKING AND PARKING FACILITIES LOCAL LAW 2008

Under the powers conferred by the *Local Government Act 1995* and under all other powers enabling it, the Council of the Shire of Northam resolved on 2008 to make the following local law.

PART 1 - DEFINITIONS AND OPERATION

1.1 Citation

This local law may be cited as the *Shire of Northam Parking and Parking Facilities Local Law 2008*.

1.2 Definitions

In this local law unless the context otherwise requires:

'ACROD sticker' has the same meaning given to it by the Code;

'Act' means the *Local Government Act 1995*;

'Authorised Person' means a person Authorised by the local government under section 9.10 of the Act, to perform any of the functions of an Authorised Person under this local law;

'Authorised vehicle' means a vehicle Authorised by the local government, Chief Executive Officer, Authorised Person or by any written law to park on a thoroughfare or parking facility;

'bicycle' has the meaning given to it by the Code;

'bicycle path' has the meaning given to it by the Code;

'bus' has the meaning given to it by the Code;

'bus embayment' has the meaning given to it by the Code;

'bus stop' has the meaning given to it by the Code;

'bus zone' has the meaning given to it by the Code;

'caravan' means a vehicle that is fitted or designed to allow human habitation and which is drawn by another vehicle, or which is capable of self-propulsion;

'carriageway' means a portion of thoroughfare that is improved, designed or ordinarily used for vehicular traffic and includes the shoulders, and areas, including embayments, at the side or centre of the carriageway, used for the stopping or parking of vehicles; and where a thoroughfare has two or more of those portions divided by a median strip, the expression means each of those portions, separately;

'centre' in relation to a carriageway, means a line or a series of lines, marks or other indications:

(i) for a two-way carriageway – placed so as to delineate vehicular traffic travelling in different directions; or

(ii) in the absence of any such lines, marks or other indications – the middle of the main, travelled portion of the carriageway;

'children's crossing' has the meaning given to it by the Code;

'CEO' means the Chief Executive Officer of the Shire of Northam;

'Code' means the *Road Traffic Code 2000*;

'commercial vehicle' means a motor vehicle constructed for the conveyance of goods or merchandise, or for the conveyance of materials used in any trade, business, industry

Formatted: Font: Not Bold

Formatted: Font: Not Bold

or work whatsoever, other than a motor vehicle for the conveyance of passengers, and includes any motor vehicle that is designed primarily for the carriage of persons, but which has been fitted or adapted for the conveyance of the goods, merchandise or materials referred to, and is in fact used for that purpose;

'district' means the district of the local government;

'driver' means any person driving or in control of a vehicle;

'edge line' for a carriageway means a line marked along the carriageway at or near the far left or the far right of the carriageway;

'emergency vehicle' has the meaning given to it by the Code;

'footpath' has the meaning given to it by the Code;

'GVM' (which stands for 'gross vehicle mass') has the meaning given to it by the Code;

'Loading Zone' means a parking stall which is set aside for use by commercial vehicles if there is a sign referable to that stall marked 'Loading Zone';

'local government' means the Shire of Northam;

'mail zone' has the meaning given to it by the Code;

'median strip' has the meaning given to it by the Code;

'metered space' means a section or part of a metered zone that is adjacent to a parking meter and that is marked or defined by painted lines or by metallic studs or similar devices for the purpose of indicating where a vehicle may be parked on payment of a fee or charge;

'metered zone' means any thoroughfare or reserve, or part of any thoroughfare or reserve, in which parking meters regulate the parking of vehicles;

'motorcycle' has the meaning given to it by the Code;

'motor vehicle' means a self-propelled vehicle that is not operated on rails; and the expression includes a trailer, semi-trailer or caravan while attached to a motor vehicle, but does not include a power assisted pedal cycle;

'no parking area' has the meaning given to it by the Code;

'no parking sign' means a sign with the words 'no parking' in red letters on a white background, or the letter 'P' within a red annulus and a red diagonal line across it on a white background;

'no stopping area' has the meaning given to it by the Code;

'no stopping sign' means a sign with the words 'no stopping' or 'no standing' in red letters on a white background or the letter 'S' within a red annulus and a red diagonal line across it on a white background;

'occupier' has the meaning given to it by the Act;

'owner'

(a) where used in relation to a vehicle licensed under the Road Traffic Act, means the person in whose name the vehicle has been registered under that Road Traffic Act;

(b) where used in relation to any other vehicle, means the person who owns, or is entitled to possession of that vehicle; and

(c) where used in relation to land, has the meaning given to it by the Act;

'park' in relation to a vehicle, means to permit a vehicle, whether attended or not by any person, to remain stationary except for the purpose of:

(a) avoiding conflict with other traffic; or

(b) complying with the provisions of any law; or

(c) taking up or setting down persons or goods (*maximum of 2 minutes*);

'parking area' has the meaning given to it by the Code;

'parking facilities' includes land, buildings, shelters, metered zones, metered spaces, parking stalls and other facilities open to the public generally for the parking of vehicles with or without charge and signs, notices and facilities used in connection with the parking of vehicles;

Formatted: Font: Not Bold

'parking meter' includes the stand on which the meter is erected and a ticket issuing machine;

'parking region' means the area described in Schedule 1;

'parking stall' means a section or part of a thoroughfare or of a parking station which is marked or defined by painted lines, metallic studs, coloured bricks or pavers or similar devices for the purpose of indicating where a vehicle may be parked, but does not include a metered space;

'parking station' means any land, or structure provided for the purpose of accommodating vehicles with or without charge, but does not include a metered zone or metered space;

'pedestrian crossing' has the meaning given to it by the Code;

'public place' means any place to which the public has access whether or not that place is on private property;

'reserve' means any land -

(a) which belongs to the local government;

(b) of which the local government is the management body under the *Land Administration Act 1997*; or which is an 'otherwise unvested facility' within section 3.53 of the Act;

'Road Traffic Act' means the *Road Traffic Act 1974*;

'Schedule' means a Schedule to this local law;

'shared zone' has the meaning given to it by the Code;

'sign' includes a traffic sign, inscription, road marking, mark, structure or device approved by the local government on which may be shown words, numbers, expressions or symbols, and which is placed on or near a thoroughfare or within a parking station or reserve for the purpose of prohibiting, regulating, guiding, directing or restricting the parking of vehicles;

'special purpose vehicle' has the meaning given to it by the Code;

'stop' in relation to a vehicle means to stop a vehicle and permit it to remain stationary, except for the purposes of avoiding conflict with other traffic or of complying with the provisions of any law;

'symbol' includes any symbol specified by Australian Standard 1742.11-2016 and any symbol specified from time to time by Standards Australia for use in the regulation of parking and any reference to the wording of any sign in this local law shall be also deemed to include a reference to the corresponding symbol;

'taxi' means a taxi within the meaning of the *Taxi Act 1994* or a taxi-car in section 47Z of the *Transport Co-ordination Act 1966*;

'taxi zone' has the meaning given to it by the Code;

'thoroughfare' has the meaning given to it by the Act;

'ticket issuing machine' means a parking meter which issues, as a result of money being inserted in the machine or such other form of payment as may be permitted to be made, a ticket showing the period during which it shall be lawful to remain parked in a metered space to which the machine is referable;

'traffic island' has the meaning given to it by the Code;

'trailer' means any vehicle without motive power of its own, designed for attachment to a motor vehicle for the purpose of being towed, but does not include the rear portion of an articulated vehicle, or a side car;

'unattended', in relation to a vehicle, means that the driver has left the vehicle so that the driver is more than 3 metres from the closest point of the vehicle.

'vehicle' has the meaning given to it by the Code;

'verge' means the portion of a thoroughfare which lies between the boundary of a carriageway and the adjacent property line but does not include a footpath.

Formatted: Tab stops: 12.59 cm, Left

1.3 Repeal

The following local laws are repealed:

- The *Shire of Northam Local Laws Relating to Parking Facilities* published in the *Government Gazette* on 1 May 1998.
- The *Town of Northam Parking Facilities By-law* published in the *Government Gazette* on 5 January 1996.

1.4 Application of particular definitions

(1) For the purposes of the application of the definitions 'no parking area' and 'parking area' an arrow inscribed on a traffic sign erected at an angle to the boundary of the carriageway is deemed to be pointing in the direction in which it would point, if the signs were turned at an angle of less than 90 degrees until parallel with the boundary.

(2) Unless the context otherwise requires, where a term is used, but not defined, in this local law, and that term is defined in the *Road Traffic Act 1974* or in the Code, then the term shall have the meaning given to it in that Act or the Code.

1.5 Application and pre-existing signs

(1) Subject to subclause (2), this local law applies to the parking region.

(2) This local law does not apply to a parking facility or a parking station that is not occupied by the local government, unless the local government and the owner or occupier of that facility or station have agreed in writing that this local law will apply to that facility or station.

(3) The agreement referred to in subclause (2) may be made on such terms and conditions as the parties may agree.

(4) Where a parking facility or a parking station is identified in Schedule 3, then the facility or station shall be deemed to be a parking station to which this local law applies and it shall not be necessary to prove that it is the subject of an agreement referred to in subclause (2).

(5) A sign that:

(a) was erected by the local government or the Commissioner of Main Roads prior to the coming into operation of this local law; and

(b) relates to the parking of vehicles within the parking region, shall be deemed for the purposes of this local law to have been erected by the local government under the authority of this local law.

(6) An inscription or symbol on a sign referred to in subclause (5) operates and has effect according to its tenor, and where the inscription or symbol relates to the stopping of vehicles, it shall be deemed for the purposes of this local law to operate and have effect as if it related to the parking of vehicles.

(7) The provisions of Parts (2), (3), (4) and (5) do not apply to a bicycle parked at a bicycle rail or bicycle rack.

1.6 Classes of vehicles

For the purpose of this local law, vehicles are divided into classes as follows:

- (a) buses;
- (b) commercial vehicles;
- (c) motorcycles and bicycles;
- (d) taxis; and
- (e) all other vehicles.

1.7 Part of thoroughfare to which sign applies

Where under this local law the parking of vehicles in a thoroughfare is controlled by a sign, the sign shall be read as applying to that part of the thoroughfare which:

- (a) lies beyond the sign;
- (b) lies between the sign and the next sign beyond that sign; and
- (c) is on that side of the thoroughfare nearest to the sign.

1.8 Powers of Local Government

The local government may, by resolution, prohibit or regulate by signs or otherwise, the stopping or parking of any vehicle or any class of vehicles in any part of the parking region but must do so consistently with the provisions of this local law.

PART 2 - METERED ZONES

2.1 Determination of metered zones

(1) The local government may by resolution constitute, determine and vary metered spaces and metered zones

(2) In respect of metered spaces and metered zones the local government may by resolution determine:

- (a) permitted times and conditions of parking depending on and varying with the locality;
- (b) classes of vehicles which are permitted to park;
- (c) the amount payable for parking; and
- (d) the manner of parking.

(3) Where the local government makes a determination under subsections (1) and (2) it shall erect signs to give effect to the determination.

2.2 Parking fee to be paid

Subject to clause 2.5, a person shall not park a vehicle in a metered space unless the appropriate fee as indicated by a sign on the parking meter referable to the space is inserted into the parking meter.

2.3 Limitation on parking in metered space

The payment of a fee under clause 2.2 shall entitle a person to park the vehicle in a metered space for the period shown on the parking meter, but does not **Authorise** the parking of the vehicle during any time when parking in that space may be prohibited in accordance with this local law.

2.4 No parking when meter is expired

Subject to clause 2.5, a person shall not leave or permit a vehicle to remain parked in a metered space during the hours when a fee is payable to park the vehicle in the space when the parking meter referable to that space exhibits the sign 'Expired' or a negative time.

2.5 Suspension of requirement to pay fee

The local government may from time to time by a resolution declare that the provisions of clauses 2.2 and 2.4 shall not apply during the periods and days specified in the resolution.

2.6 Vehicles to be within metered space

Subject to subclause (2):

(1) A person shall not park a vehicle in a metered space in a thoroughfare otherwise than parallel to and as close to the kerb as practicable and wholly within the space, provided

that where a metered space is set out otherwise than parallel to the kerb the vehicle need only park wholly within the space.

(2) If a vehicle is too long or too wide to fit completely within a single metered space then the person parking the vehicle shall do so within the minimum number of metered spaces needed to park that vehicle.

(3) A person shall not park a vehicle partly within and partly outside a metered zone.

2.7 Permitted insertions in parking meters

(1) A person shall not insert into a parking meter anything other than the designations of coin or banknote or such other permitted form of payment indicated by a sign on the parking meter.

(2) The insertion of a coin or banknote into any parking meter or the making of payment in such other form as may be permitted shall be effected only in accordance with the instructions printed on that particular meter.

2.8 Parking ticket to be clearly visible

A driver of a vehicle left parked in a metered zone which is regulated by a ticket issuing machine shall on purchasing a ticket from the machine for a period of parking, place the ticket inside the vehicle in such a position that the ticket is clearly visible to and the expiry time or time for which the ticket remains valid is able to be read by an **Authorised Person** examining the ticket from outside the vehicle.

2.9 One vehicle per metered space

A person shall not park or attempt to park a vehicle in a metered space in which another vehicle is parking.

2.10 No parking when hood on meter

Notwithstanding any other provision of this local law and notwithstanding any other sign or notice, a person shall not park a vehicle in a metered space if the parking meter referable to such metered space has a hood marked 'No Parking', 'Reserved Parking' or 'Temporary Bus Stand' or equivalent symbols depicting these purposes except with the permission of the local government or an **Authorised Person**.

PART 3 - PARKING STALLS AND PARKING STATIONS

3.1 Determination of parking stalls and parking stations

(1) The local government may by resolution constitute, determine and vary:

- (a) parking stalls;
- (b) parking stations;
- (c) permitted time and conditions of parking in parking stalls and parking stations which may vary with the locality;
- (d) permitted classes of vehicles which may park in parking stalls and parking stations;
- (e) permitted classes of persons who may park in specified parking stalls or parking stations; and
- (f) the manner of parking in parking stalls and parking stations.

(2) Where the local government makes a determination under subsection (1) it shall erect signs to give effect to the determination.

3.2 Vehicles to be within parking stall on thoroughfare

(1) Subject to subclause (2), (3) and (4), a person shall not park a vehicle in a parking stall in a thoroughfare otherwise than:

- (a) parallel to and as close to the kerb as is practicable;
- (b) wholly within the stall; and
- (c) headed in the direction of the movement of traffic on the side of the thoroughfare in which the stall is situated.

- (2) Subject to subclause (3) where a parking stall in a thoroughfare is set out otherwise than parallel to the kerb, then a person must park a vehicle in that stall wholly within it.
- (3) If a vehicle is too long or too wide to fit completely within a single parking stall then the person parking the vehicle shall do so within the minimum number of parking stalls needed to park that vehicle.
- (4) A person shall not park a vehicle partly within and partly outside a parking area.

3.3 Payment of fee to park in parking station

A person shall not park a vehicle or permit a vehicle to remain parked in any parking station during any period for which a fee is payable unless:

- (a) in the case of a parking station having an **Authorised** Person on duty, the appropriate fee is paid when demanded; or
- (b) in the case of a parking station equipped with parking meters, the appropriate fee is inserted in the meter or the required payment is made in such other form as may be permitted.

3.4 Suspension of parking station restrictions

The local government may by resolution declare that the provisions of clause 3.3 do not apply during periods on particular days in relation to particular parking stations as specified in such resolution.

3.5 Vehicle not to be removed until fee paid

A person shall not remove a vehicle which has been parked in a parking station until there has been paid the appropriate fee for the period for which the vehicle has been parked.

3.6 Entitlement to receipt

A person paying a fee at a parking station is to be entitled to receive a receipt on demand showing the period of parking covered by such payment.

3.7 Parking ticket to be clearly visible

A driver of a vehicle in a parking station which is equipped with a ticket issuing machine shall on purchasing a ticket from the machine for a period of parking, place the ticket inside the vehicle in such a position that the ticket is clearly visible to and the expiry time or time for which the ticket remains valid is able to be read by an **Authorised** Person examining the ticket from outside the vehicle.

3.8 Parking prohibitions and restrictions

- (1) A person shall not:
- (a) park a vehicle so as to obstruct an entrance to, or an exit from a parking station, or an access way within a parking station;
 - (b) except with the permission of the local government or an **Authorised** Person park a vehicle on any part of a parking station contrary to a sign referable to that part;
 - (c) permit a vehicle to park on any part of a parking station, if an **Authorised** Person directs the driver of such vehicle to move the vehicle; or
 - (d) park or attempt to park a vehicle in a parking stall in which another vehicle is parked but this paragraph does not prevent the parking of a motorcycle and a bicycle together in a stall marked 'M/C', if the bicycle is parked in accordance with subclause (2).

- (2) No person shall park any bicycle:
(a) in a parking stall other than in a stall marked 'M/C'; and
(b) in such stall other than against the kerb.
- (3) Notwithstanding the provisions of subclause (1)(b) a driver may park a vehicle in a permissive parking stall or station (except in a parking area for people with disabilities) for twice the length of time allowed, provided that:
(a) the driver's vehicle displays an ACROD sticker; and
(b) a person with disabilities to which that ACROD sticker relates is either the driver of or a passenger in the vehicle.

Commented [CV1]: Do we have any MC parks

PART 4 - PARKING GENERALLY

4.1 Restrictions on parking in particular areas

- (1) Subject to subclause (2), a person shall not park a vehicle in a thoroughfare or part of a thoroughfare, or part of a parking station:
(a) if by a sign it is set apart for the parking of vehicles of a different class;
(b) if by a sign it is set apart for the parking of vehicles by persons of a different class;
or
(c) during any period when the parking of vehicles is prohibited by a sign.
- (2) (a) This subclause applies to a driver if:
(i) the driver's vehicle displays an ACROD sticker; and
(ii) a disabled person to which the ACROD sticker relates is either the driver of the vehicle or a passenger in the vehicle.
(b) The driver may park a vehicle in a thoroughfare or a part of a thoroughfare or part of a parking station, except in a thoroughfare or a part of a thoroughfare or part of a parking station to which a disabled parking sign relates for twice the period indicated on the sign.
- (3) A person shall not park a vehicle:
(a) in a no parking area;
(b) in a parking area, except in accordance with both the signs associated with the parking area and with this local law;
(c) in a stall marked 'M/C' unless it is a motorcycle without a sidecar or a trailer, or it is a bicycle.
- (4) A person shall not park a motorcycle without a sidecar or a trailer, or a bicycle in a parking stall unless the stall is marked 'M/C'.
- (5) A person shall not, without the prior permission of the local government, the CEO, or an Authorised Person, park a vehicle in an area designated by a sign stating 'Authorised Vehicles Only'.

Formatted: Highlight

Formatted: Highlight

Commented [CV2]: Impossible to police, where are the M/C parks

4.2 Parking vehicle on a carriageway

- (1) A person parking a vehicle on a carriageway other than in a parking stall shall park it:
(a) in the case of a two-way carriageway, so that it is as near as practicable to and parallel with, the left boundary of the carriageway and headed in the direction of the movement of traffic on the side of the thoroughfare on which the vehicle is parked;
(b) in the case of a one-way carriageway, so that it is as near as practicable to and parallel with either boundary of the carriageway and headed in the direction of the movement of traffic on the side of the thoroughfare on which the vehicle is parked;
(c) so that at least 3 metres of the width of the carriageway lies between the vehicle and the farther boundary of the carriageway, or any continuous line or median strip, or between the vehicle and a vehicle parked on the farther side of the carriageway.

- (d) so that the front and the rear of the vehicle respectively is not less than 1 metre from any other vehicle, except a motorcycle without a trailer, or a bicycle parked in accordance with this local law, and
 - (e) so that it does not obstruct any vehicle on the carriageway, unless otherwise indicated on a parking regulation sign or markings on the roadway.
- (2) In this clause, 'continuous dividing line' means –
- (a) a single continuous dividing line only,
 - (b) a single continuous dividing line to the left or right of a broken dividing line, or
 - (c) 2 parallel continuous dividing lines.

4.3 When parallel and right-angled parking apply

Where a traffic sign associated with a parking area is not inscribed with the words 'angle parking' (or with an equivalent symbol depicting this purpose), then unless a sign associated with the parking area indicates, or marks on the carriageway indicate, that vehicles have to park in a different position, where the parking area is:

- (a) adjacent to the boundary of a carriageway, a person parking a vehicle in the parking area shall park it as near as practicable to and parallel with that boundary, and
- (b) at or near the centre of the carriageway, a person parking a vehicle in that parking area shall park it at approximately right angles to the centre of the carriageway.

4.4 ~~Angle parking~~

- (1) ~~Angle parking~~ does not apply to:
- a passenger vehicle or a commercial vehicle with a mass including any load, of over three tonnes, or
- (2) Where a sign associated with a parking area is inscribed with the words 'angle parking' (or with an equivalent symbol depicting this purpose), a person parking a vehicle in the area shall park the vehicle at an angle of approximately 45 degrees to the centre of the carriageway unless otherwise indicated by the inscription on the parking sign or by marks on the carriageway.

~~Deleted: When a~~

~~Deleted: applies~~

~~Deleted: This clause~~

~~Deleted: (a)~~

~~Formatted: Indent: Left: 0.75 cm, First line: 0.1 cm~~

~~Deleted:~~

~~Deleted: (b) a person parking either a motor cycle without a trailer or a bicycle.¶~~

4.5 General prohibitions on parking

- (1) (a) This clause does not apply to a vehicle parked in a parking stall nor to a bicycle in a bicycle rack
- (b) Subclauses (2)(c), (e) and (g) do not apply to a vehicle which parks in a bus embayment.
- (2) Subject to any law relating to intersections with traffic control signals a person shall not park a vehicle so that any portion of the vehicle is:
- (a) between any other stationary vehicles and the centre of the carriageway;
 - (b) on or adjacent to a median strip;
 - (c) obstructing a right of way, private drive or carriageway or so close as to deny a vehicle reasonable access to or egress from the right of way, private drive or carriageway;
 - (d) alongside or opposite any excavation, works, hoarding, scaffolding or obstruction on the carriageway, if the vehicle would obstruct traffic;
 - (e) on or within 10 metres of any portion of a carriageway bounded by a traffic island;
 - (f) on any footpath or pedestrian crossing;
 - (g) between the boundaries of a carriageway and any double longitudinal line consisting of two continuous lines or between a double longitudinal line consisting of a continuous line and a broken or dotted line and the boundary of a carriageway nearer to the continuous line, unless there is a distance of at least 3 metres clear between the vehicle and the double longitudinal line;

- (h) on an intersection, except adjacent to a carriageway boundary that is not broken by an intersecting carriageway;
 - (i) within 1 metre of a fire hydrant or fire plug, or of any sign or mark indicating the existence of a fire hydrant or fire plug;
 - (j) within 3 metres of a public letter box, unless the vehicle is being used for the purposes of collecting postal articles from the public letter box; or
 - (k) within 10 metres of the nearer property line of any thoroughfare intersecting the thoroughfare on the side on which the vehicle is parked,
- unless a sign or markings on the carriageway indicate otherwise.
- (3) A person shall not park a vehicle so that any portion of the vehicle is within 10 metres of the departure side of:
- (a) a sign inscribed with the words 'Bus Stop' or 'Hail Bus Here' (or with equivalent symbols depicting these purposes) unless the vehicle is a bus stopped to take up or set down passengers; or
 - (b) a children's crossing or pedestrian crossing.
- (4) A person shall not park a vehicle so that any portion of the vehicle is within 20 metres of the approach side of:
- (a) a sign inscribed with the words 'Bus Stop' or 'Hail Bus Here' (or with equivalent symbols depicting these purposes) unless the vehicle is a bus stopped to take up or set down passengers;
 - (b) a children's crossing or pedestrian crossing.
- (5) A person shall not park a vehicle so that any portion of the vehicle is within 20 metres of either the approach side or the departure side of the nearest rail of a railway level crossing.

Deleted: pillar

4.6 Authorised person may order vehicle on thoroughfare to be moved

The driver of a vehicle shall not park that vehicle on any part of a thoroughfare in contravention of this local law after an Authorised Person has directed the driver to move it.

4.7 Authorised person may mark tyres

- (1) An Authorised Person may mark the tyres of a vehicle parked in a parking facility with chalk or any other non-indelible substance for a purpose connected with or arising out of his or her duties or powers.
- (2) A person shall not remove a mark made by an Authorised Person so that the purpose of the affixing of such a mark is defeated or likely to be defeated.

4.8 No movement of vehicles to avoid time limitation

- (1) Where the parking of vehicles in a parking facility is permitted for a limited time, a person shall not move a vehicle within the parking facility so that the total time of parking exceeds the maximum time allowed for parking in the parking facility.
- (2) Where the parking of vehicles in a thoroughfare is permitted for a limited time, a person shall not move a vehicle along that thoroughfare so that the total time of parking exceeds the maximum time permitted, unless the vehicle has first been removed from the thoroughfare for at least two hours.

4.9 No parking of vehicles exposed for sale and in other circumstances

- A person shall not park a vehicle on any portion of a thoroughfare:
- (a) for the purpose of exposing it for sale;
 - (b) if that vehicle is not licensed under the Road Traffic Act;
 - (c) if that vehicle is a trailer or a caravan unattached to a motor vehicle; or

- (d) for the purpose of effecting repairs to it, other than the minimum repairs necessary to enable the vehicle to be moved to a place other than a thoroughfare.

4.10 Parking on private land

- (1) In this clause a reference to 'land' does not include land:
 - (a) which belongs to the local government;
 - (b) of which the local government is the management body under the *Land Administration Act 1997*;
 - (c) which is an 'otherwise unvested facility' within section 3.53 of the Act;
 - (d) which is the subject of an agreement referred to in subclause 1.5(2); or
 - (e) which is identified in Schedule 3.
- (2) A person shall not park a vehicle on land without the consent of the owner or occupier of the land on which the vehicle is parked.
- (3) Where the owner or occupier of the land, by a sign referable to that land or otherwise, consents to the parking of vehicles of a specified class or classes on the land for a limited period, a person shall not park a vehicle on the land otherwise than in accordance with the consent.

4.11 Parking on reserves

No person other than an employee of the local government in the course of his or her duties or a person **Authorised** by the local government shall drive or park a vehicle upon or over any portion of a reserve other than upon an area specifically set aside for that purpose.

4.12 Suspension of parking limitations for urgent, essential or official duties

- (1) Where by a sign the parking of vehicles is permitted for a limited time on a portion of a thoroughfare or parking facility, the local government, the CEO or an **Authorised** Person may, subject to the Code, permit a person to park a vehicle in that portion of the thoroughfare or parking facility for longer than the permitted time in order that the person may carry out urgent, essential or official duties.
- (2) Where permission is granted under subclause (1), the local government, the CEO or an **Authorised** Person may prohibit the use by any other vehicle of that portion of the thoroughfare or parking facility to which the permission relates, for the duration of that permission.

PART 5 – PARKING AND STOPPING GENERALLY

5.1 No stopping and no parking signs, and yellow edge lines

- (1) No stopping
A driver shall not stop on a length of carriageway, or in an area, to which a 'no stopping' sign applies.
- (2) No parking
A driver shall not stop on a length of carriageway or in an area to which a 'no parking' sign applies, unless the driver is:
 - (a) dropping off, or picking up, passengers or goods;
 - (b) does not leave the vehicle unattended; and
 - (c) completes the dropping off, or picking up, of the passengers or goods within 2 minutes of stopping and drives on.
- (3) A driver shall not stop at the side of a carriageway marked with a continuous yellow edge line.

Deleted: 'unattended', in relation to a vehicle, means that the driver has left the vehicle so that the driver is more than 3 metres from the closest point of the vehicle.]]

Deleted: No stopping on a carriageway with yellow edge lines]]

PART 6 – STOPPING IN ZONES FOR PARTICULAR VEHICLES

6.1 Stopping in a loading zone

A person shall not stop a vehicle in a loading zone unless it is:

- (a) a motor vehicle used for commercial or trade purposes engaged in the picking up or setting down of goods; or
 - (b) a motor vehicle taking up or setting down passengers,
- but, in any event, shall not remain in that loading zone:
- (c) for longer than a time indicated on the 'loading zone' sign; or
 - (d) longer than 30 minutes (if no time is indicated on the sign).

6.2 Stopping in a taxi zone or a bus zone

(1) A driver shall not stop in a taxi zone, unless the driver is driving a taxi.

(2) A driver shall not stop in a bus zone unless the driver is driving a public bus, or a bus of a type that is permitted to stop at the bus zone by information on or with the 'bus zone' sign applying to the bus zone.

6.3 Stopping in a mail zone

A person shall not stop a vehicle in a mail zone.

6.4 Other limitations in zones

A person shall not stop a vehicle in a zone to which a traffic sign applies if stopping the vehicle would be contrary to any limitation in respect to classes of persons or vehicles, or specific activities allowed, as indicated by additional words on a traffic sign that applies to the zone.

PART 7 – OTHER PLACES WHERE STOPPING IS RESTRICTED

7.1 Stopping in a shared zone

A driver shall not stop in a shared zone unless:

- (1) the driver stops at a place on a length of carriageway, or in an area, to which a parking control sign applies and the driver is permitted to stop at that place under this local law;
- (2) the driver stops in a parking bay and the driver is permitted to stop in the parking bay under this local law;
- (3) the driver is dropping off, or picking up, passengers or goods; or
- (4) the driver is engaged in door-to-door delivery or collection of goods, or in the collection of waste or garbage.

7.2 Double parking

(1) A driver shall not stop a vehicle so that any portion of the vehicle is between any other stopped vehicle and the centre of the carriageway.

(2) This clause does not apply to:

- (a) a driver stopped in traffic; or
- (b) a driver angle parking on the side of the carriageway or in a median strip parking area, in accordance with this local law.

7.3 Stopping near an obstruction

A driver shall not stop on a carriageway near an obstruction on the carriageway in a position that further obstructs traffic on the carriageway.

7.4 Stopping on a bridge or in a tunnel, etc.

- (1) A driver shall not stop a vehicle on a bridge, causeway, ramp or similar structure unless:
- (a) the carriageway is at least as wide on the structure as it is on each of the approaches and a traffic sign does not prohibit stopping or parking; or
 - (b) the driver stops at a place on a length of carriageway, or in an area, to which a parking control sign applies and the driver is permitted to stop at that place under this local law.
- (2) A driver shall not stop a vehicle in a tunnel or underpass unless:
- (a) the carriageway is at least as wide in the tunnel or underpass as it is on each of the approaches and a traffic sign does not prohibit stopping or parking; or
 - (b) the driver of a motor vehicle stops at a bus stop, or in a bus zone or parking area marked on the carriageway, for the purpose of setting down or taking up passengers.

7.5 Stopping on crests, curves, etc.

- (1) Subject to subclause (2), a driver shall not stop a vehicle on, or partly on, a carriageway, in any position where it is not visible to the driver of an overtaking vehicle, from a distance of 50 metres within a built-up area, and from a distance of 150 metres outside a built-up area.
- (2) A driver may stop on a crest or curve on a carriageway that is not in a built-up area if the driver stops at a place on the carriageway, or in an area, to which a parking control sign applies and the driver is permitted to stop at that place under this local law.

7.6 Stopping near a fire hydrant etc.

- (1) A driver shall not stop a vehicle so that any portion of the vehicle is within one metre of a fire hydrant or fire plug, or of any sign or mark indicating the existence of a fire hydrant or fire plug, unless:
- (a) the driver is driving a public bus, and the driver stops in a bus zone or at a bus stop and does not leave the bus unattended; or
 - (b) the driver is driving a taxi, and the driver stops in a taxi zone and does not leave the taxi unattended.
- (2) In this clause a driver leaves the vehicle 'unattended' if the driver leaves the vehicle so the driver is over 3 metres from the closest point of the vehicle.

7.7 Stopping at or near a bus stop

- (1) A driver shall not stop a vehicle so that any portion of the vehicle is within 20 metres of the approach side of a bus stop, or within 10m of the departure side of a bus stop, unless:
- (a) the vehicle is a public bus stopped to take up or set down passengers; or
 - (b) the driver stops at a place on a length of carriageway, or in an area, to which a parking control sign applies and the driver is permitted to stop at that place under this local law.
- (2) In this clause:
- (a) distances are measured in the direction in which the driver is driving; and
 - (b) a trailer attached to a public bus is deemed to be a part of the public bus.

7.8 Stopping on a path, median strip, or traffic island

The driver of a vehicle (other than a bicycle or an animal) shall not stop so that any portion of the vehicle is on a path, traffic island or median strip, unless the driver stops in an area, to which a parking control sign applies and the driver is permitted to stop at that place under this local law.

7.9 Stopping on verge

(1) A person shall not:

- (a) stop a vehicle other than a bicycle;
- (b) stop a commercial vehicle or bus, or a trailer or caravan unattached to a motor vehicle; or
- (c) stop a vehicle during any period when the stopping of vehicles on that verge is prohibited by a sign adjacent and referable to that verge,

so that any portion of it is on a verge.

(2) Subclause (1)(a) does not apply to the person if he or she is the owner or occupier of the premises adjacent to that verge, or is a person authorised by the occupier of those premises to stop the vehicle so that any portion of it is on the verge.

(3) Subclause (1)(b) does not apply to a commercial vehicle when it is being loaded or unloaded with reasonable expedition with goods, merchandise or materials collected from or delivered to the premises adjacent to the portion of the verge on which the commercial vehicle is parked, provided no obstruction is caused to the passage of any vehicle or person using a carriageway or a path.

7.10 Obstructing access to and from a path, driveway, etc.

(1) A driver shall not stop a vehicle so that any portion of the vehicle is in front of a path, in a position that obstructs access by vehicles or pedestrians to or from that path, unless:

- (a) the driver is dropping off, or picking up, passengers; or
- (b) the driver stops in a parking stall and the driver is permitted to stop in the parking stall under this local law.

(2) A driver shall not stop a vehicle on or across a driveway or other way of access for vehicles travelling to or from adjacent land, unless:

- (a) the driver is dropping off, or picking up, passengers; or
- (b) the driver stops in a parking stall and the driver is permitted to stop in the parking stall under this local law.

7.11 Stopping near a letter box

A driver shall not stop a vehicle so that any portion of the vehicle is within 3 metres of a public letter box, unless the driver:

- (a) is dropping off, or picking up, passengers or mail; or
- (b) stops at a place on a length of carriageway, or in an area, to which a parking control sign applies and the driver is permitted to stop at that place under this local law.

7.12 Stopping on a carriageway – heavy and long vehicles

(1) A person shall not park a vehicle or any combination of vehicles, that, together with any projection on, or load carried by, the vehicle or combination of vehicles, is 7.5 metres or more in length or exceeds a GVM of 4.5 tonnes:

- (a) on a carriageway in a built-up area, for any period exceeding one hour, unless engaged in the picking up or setting down of goods; or
- (b) on a carriageway outside a built-up area, except on the shoulder of the carriageway, or in a truck bay or other area set aside for the parking of goods vehicles.

(2) Nothing in this clause mitigates the limitations or condition imposed by any other clause or by any local law or traffic sign relating to the parking or stopping of vehicles

Deleted: (

Deleted: (

7.13 Stopping on a carriageway with a bicycle parking sign

The driver of a vehicle (other than a bicycle) shall not stop on a length of carriageway to which a 'bicycle parking' sign applies, unless the driver is dropping off, or picking up, passengers.

7.14 Stopping on a carriageway with motorcycle parking sign

The driver of a vehicle shall not stop on a length of carriageway, or in an area, to which a 'motorcycle parking' sign applies, or an area marked 'M/C' unless:

- (a) the vehicle is a motorcycle; or
- (b) the driver is dropping off, or picking up, passengers.

Deleted: motor cycle

Deleted: motor cycle

Deleted: motor cycle

7.15 Stopping in a parking stall for people with disabilities

(1) A driver shall not stop in a parking area for people with disabilities unless:

- (a) the driver's vehicle displays an ACROD sticker; and
- (b) either the driver or the passenger in that vehicle is a person with disabilities.

(2) In this clause a 'parking area for people with disabilities' is a length or area:

- (a) to which a 'permissive parking' sign displaying a people with disabilities symbol applies;
- (b) to which a 'people with disabilities parking' sign applies;
- (c) indicated by a road marking (a 'people with disabilities road marking') that consists of, or includes, a people with disabilities symbol; or
- (d) set aside within a parking region as a 'parking stall for use of a disabled person' under the *Local Government (Parking for People with Disabilities) Regulations 2014*.

Deleted: Disabled Persons

Deleted: 1988

PART 8 – MISCELLANEOUS

8.1 Removal of notices on vehicle

A person, other than the driver of the vehicle or a person acting under the direction of the driver of the vehicle, shall not remove from the vehicle any notice put on the vehicle by an Authorised Person.

8.2 Unauthorised signs and defacing of signs

A person shall not without the authority of the local government

- (a) mark, set up or exhibit a sign purporting to be or resembling a sign marked, set up or exhibited by the local government under this local law;
- (b) remove, deface or misuse a sign or property, set up or exhibited by the local government under this local law or attempt to do any such act; or
- (c) affix a board, sign, placard, notice or other thing to or paint or write upon any part of a sign set up or exhibited by the local government under this local law.

8.3 Signs must be complied with

An inscription or symbol on a sign operates and has effect according to its tenor and a person contravening the direction on a sign commits an offence under this local law.

8.4 General provisions about signs

(1) A sign marked, erected, set up, established or displayed on or near a thoroughfare is, in the absence of evidence to the contrary presumed to be a sign marked, erected, set up, established or displayed under the authority of this local law.

(2) The first three letters of any day of the week when used on a sign indicate that day of the week.

8.5 Special purpose and emergency vehicles

Notwithstanding anything to the contrary in this local law, the driver of:

- (1) a special purpose vehicle may, only in the course of his or her duties and when it is expedient and safe to do so, stop, or park the vehicle in any place, at any time; and
- (2) an emergency vehicle may, in the course of his or her duties and when it is expedient and safe to do so or where he or she honestly and reasonably believes that it is expedient and safe to do so, stop, or park the vehicle at any place, at any time.

8.6 Vehicles not to obstruct a public place

- (1) A person shall not leave a vehicle, or any part of a vehicle, in a public place so that it obstructs the use of any part of that public place without the permission of the local government or unless **Authorised** under any written law.
- (2) A person will not contravene subclause (1) where the vehicle is left for a period not exceeding 24 hours.

PART 9 - PENALTIES

9.1 Offences and penalties

- (1) Any person who fails to do anything required or directed to be done under this local law, or who does anything which under this local law that person is prohibited from doing, commits an offence.
- (2) An offence against any provision of this local law is a prescribed offence for the purposes of section 9.16(1) of the Act.
- (3) Any person who commits an offence under this local law shall be liable, upon conviction, to a penalty not exceeding \$5,000, and if the offence is of a continuing nature, to an additional penalty not exceeding \$500 for each day or part of a day during which the offence has continued.
- (4) The amount appearing in the final column of Schedule 2 directly opposite a clause specified in that Schedule is the modified penalty for an offence against that clause.

9.2 Form of notices

For the purposes of this local law:

- (a) the form of the notice referred to in section 9.13 of the Act is that of Form 1 in Schedule 1 of the *Local Government (Functions and General) Regulations 1996*;
- (b) the form of the infringement notice referred to in section 9.17 of the Act is that of Form 2 in Schedule 1 of the *Local Government (Functions and General) Regulations 1996*;
- (c) the form of the infringement withdrawal notice referred to in section 9.20 of the Act is that of Form 3 in Schedule 1 of the *Local Government (Functions and General) Regulations 1996*.

**SCHEDULE 1
PARKING REGION
PARKING AND PARKING FACILITIES LOCAL LAW 2008**

The parking region is the whole of the district, but excludes the following portions of the district:

- (1) the approach and departure prohibition areas of all existing and future traffic control signal installations as determined by the Commissioner of Main Roads;
- (2) prohibition areas applicable to all existing and future bridges and subways as determined by the Commissioner of Main Roads; and
- (3) any road which comes under the control of the Commissioner of Main Roads unless the control of parking and parking facilities on that road is carried out subject to the control and direction of the Commissioner of Main Roads or has been delegated by the Commissioner to the local government.

SCHEDULE 2 (CLAUSE 9.1)
PRESCRIBED OFFENCES
PARKING AND PARKING FACILITIES LOCAL LAW 2008

ITEM NO.	CLAUSE NO.	NATURE OF OFFENCE	MODIFIED PENALTY \$
1	2.2	Failure to pay fee for metered space	55
2	2.3	Parking in excess of period shown on metered space	40
3	2.4	Parking when meter has expired	55
4	2.6(1)	Failure to park wholly within metered space	40
5	2.6(3)	Parking outside metered zone	40
6	2.7	Non-permitted insertion in parking meter	55
7	2.8	Failure to display ticket clearly in metered zone	50
8	2.9	Parking or attempting to park a vehicle in a metered space occupied by another vehicle	40
9	2.10	Parking contrary to a meter hood	50
10	3.2	Failure to park wholly within parking stall	60
11	3.2(4)	Failure to park wholly within parking area	60
12	3.3	Failure to pay parking station fee	55
13	3.5	Leaving without paying parking station fee	55
14	3.7	Failure to display ticket clearly in parking station	50
15	3.8(1)(a)	Causing obstruction in parking station	50
16	3.8(1)(b)	Parking contrary to sign in parking station	50
17	3.8(1)(b)	Parking a vehicle in a parking station for the disabled	120
18	3.8(1)(c)	Parking contrary to directions of Authorised Person	60
19	3.8(1)(d)	Parking or attempting to park a vehicle in a parking stall occupied by another vehicle	40
20	4.1(1)(a)	Parking wrong class of vehicle	40
21	4.1(1)(b)	Parking by persons of a different class	45
22	4.1(1)(c)	Parking during prohibited period	45
23	4.1(3)(a)	Parking in no parking area	60
24	4.1(3)(b)	Parking contrary to signs or limitations	60
25	4.1(3)(c)	Parking vehicle in motorcycle only area	60
26	4.1(4)	Parking motorcycle in stall not marked 'M/C'	60
27	4.1(5)	Parking without permission in an area designated for 'Authorised Vehicles Only'	60
28	4.2(1)(a)	Failure to park on the left of two-way carriageway	60

Deleted: motor cycle

Deleted: motor cycle

29	4.2(1)(b)	Failure to park on boundary of one-way carriageway	60
30	4.2(1)(a) or 4.2(1)(b)	Parking against the flow of traffic	60
31	4.2(1)(c)	Parking when distance from farther boundary less than 3 metres	45
32	4.2(1)(d)	Parking closer than 1 metre from another vehicle	40
33	4.2(1)(e)	Causing obstruction	60
34	4.3(b)	Failure to park at approximate right angle	60
35	4.4(2)	Failure to park at an appropriate angle	60
36	4.5(2)(a) and 7.2	Double parking	60
37	4.5(2)(b)	Parking on or adjacent to a median strip	60
38	4.5(2)(c)	Denying access to private drive or right of way	60
39	4.5(2)(d)	Parking beside excavation or obstruction so as to obstruct traffic	60
40	4.5(2)(e)	Parking within 10 metres of traffic island	60
41	4.5(2)(f)	Parking on footpath/pedestrian crossing	60
42	4.5(2)(g)	Parking contrary to continuous line markings	60
43	4.5(2)(h)	Parking on intersection	60
44	4.5(2)(i)	Parking within 1 metre of fire hydrant or fire plug	60
45	4.5(2)(j)	Parking within 3 metres of public letter box	60
46	4.5(2)(k)	Parking within 10 metres of intersection	60
47	4.5(3)(a) or (b)	Parking vehicle within 10 metres of departure side of bus stop, children's crossing or pedestrian crossing	60
48	4.5(4)(a) or (b)	Parking vehicle within 20 metres of approach side of bus stop, children's crossing or pedestrian crossing	60
49	4.5(5)	Parking vehicle within 20 metres of approach side or departure side of railway level crossing	60
50	4.6	Parking contrary to direction of Authorised Person	60
51	4.7(2)	Removing mark of Authorised Person	60
52	4.8	Moving vehicle to avoid time limitation	60
53	4.9(a)	Parking in thoroughfare for purpose of sale	60
54	4.9(b)	Parking unlicensed vehicle in thoroughfare	60
55	4.9(c)	Parking a trailer/caravan on a thoroughfare	60
56	4.9(d)	Parking in thoroughfare for purpose of repairs	60
57	4.10(1) or (2)	Parking on land that is not a parking facility without consent	60
58	4.10(3)	Parking on land not in accordance with consent	60

59	4.11	Driving or parking on reserve	60
60	5.1(1)	Stopping contrary to a 'no stopping' sign	60
61	5.1(2)	Parking contrary to a 'no parking' sign	60
62	5.1(3)	Stopping within continuous yellow lines	60
63	6.1	Stopping unlawfully in a loading zone	60
64	6.2	Stopping unlawfully in a taxi zone or bus zone	60
65	6.3	Stopping unlawfully in a mail zone	60
66	6.4	Stopping in a zone contrary to a sign	60
67	7.1	Stopping in a shared zone	60
68	7.3	Stopping near an obstruction	60
69	7.4	Stopping on a bridge or tunnel	60
70	7.5	Stopping on crests/curves etc	60
71	7.6	Stopping near fire hydrant	60
72	7.7	Stopping near bus stop	60
73	7.8	Stopping on path, median strip or traffic island	60
74	7.9	Stopping on verge	60
75	7.10	Obstructing path, a driveway etc	60
76	7.11	Stopping near letter box	60
77	7.12	Stopping heavy or long vehicles on carriageway	60
78	7.13	Stopping in bicycle parking area	60
79	7.14	Stopping in motorcycle parking area	60
80	7.15	Unauthorised vehicle Stopping in disabled parking area	60
81	8.6	Leaving vehicle so as to obstruct a public place	60
82		All other offences not specified	60

Deleted: 120

Formatted: Highlight

**SCHEDULE 3
DEEMED PARKING STATIONS
PARKING AND PARKING FACILITIES LOCAL LAW 2008**

Dated:

The Common Seal of the Shire of Northam was hereto affixed by the authority of a resolution of the Council in the presence of:

CR S.B. POLLARD, Shire President
G. BRENNAN, Acting Chief Executive Officer

12.4.5 Standing Orders Repeal Local Law 2017

Address:	N/A
Owner:	Shire of Northam
File Reference:	2.3.2.4
Reporting Officer:	Cheryl Greenough Coordinator Governance / Administration
Responsible Officer:	Colin Young Executive Manager Corporate Services
Voting Requirement	Simple Majority

BRIEF

This report is for Councillors to decide if they would like to Repeal or Amend the Shire of Northam Standing Orders Local Law 2008.

ATTACHMENTS

Attachment 1: Standing Orders Local Law 2008.

Attachment 2: Standing Orders Local Law 2017.

BACKGROUND / DETAILS

The Standing Orders Local Law 2008 was Gazetted on 16 September 2008.

At the Ordinary Council meeting 25 January 2017, Council put forward a motion to commence the first stage of reviewing all of the 2008 local laws. Following on from that motion, a consultation period of six (6) weeks was held from 28 January 2017 ending on 20 March 2017.

On 20 March 2017 the Department of Local Government, Sport and Cultural Industries (formerly Department of Local Government and Communities) advised their recommendations for amendments to the Local Law.

No comments were received from the community during the review process and as such the Shire staff conducted a workshop with several Councillors to discuss the changes provided by the Department and any other changes staff have deemed as necessary. The statutory review of the Shire's Standing Orders Local Law 2008 in accordance with s.3.16 of the Act has now been finalised.

Council must now decide if they wish to repeal or amend the local law in accordance with section 3.12 of the Act, which is the same process/procedure

for 'making' a local law. This is because amended or repealed local laws are new local laws in themselves and must follow the full statutory process to be made within power.

The following table outlines what stage of the process this local law is currently at:

2008 Local Laws	Stage 1	s3.16	Council adopted to review Local Law & advertise for 6 weeks	Stage 2	s3.12	Council adopts to either make changes to the local law and advertise the changes or repeal	Stage 3	Council adopt the new local law, advertise & send for Gazettal
Dogs Local Law 2008								Lay on Table at November meeting
Cemeteries Local law 2008								Accepted at November meeting
Activities on Thoroughfares								
Extractive Industries								
Standing Orders								
Operation of Waste Facilities								
Parking and Parking Facilities								
Health Local Law 2008								
Keeping Control of cats								
Local Government Property								

CONSIDERATIONS

Strategic Community / Corporate Business Plan

Theme Area 6: Governance & Leadership.

Outcome 6.3: The Shire of Northam council is a sustainable, responsive, innovative and transparent organisation.

- Implement systems and processes which deliver quality outcomes for our community;
- Maintain a high standard of corporate governance;



- Encourage active community participation in our local government; and
- Undertake our regulatory roles in a safe, open, accountable and respectful manner.

Financial / Resource Implications

Repealing a local law process will incur:

- Advertising costs in the West Australian - Approximate cost \$400;
- Advertising in the Avon Advocate relating to the adoption of the amendment local law. Approximate cost \$200; and
- Further Gazettal costs when adopted which will be approximately \$3,000

Legislative Compliance

Section 3.12 of the Local Government Act 1995 which outline the procedures for making local laws.

- (2) *In making a local law a local government is to follow the procedure described in this section, in the sequence in which it is described.*
- (2A) *Despite subsection (1), a failure to follow the procedure described in this section does not invalidate a local law if there has been substantial compliance with the procedure.*
- (2) *At a council meeting the person presiding is to give notice to the meeting of the purpose and effect of the proposed local law in the prescribed manner.*
- (3) *The local government is to —*
- (a) *give Statewide public notice stating that —*
- (i) *the local government proposes to make a local law the purpose and effect of which is summarized in the notice; and*
- (ii) *a copy of the proposed local law may be inspected or obtained at any place specified in the notice; and*
- (iii) *submissions about the proposed local law may be made to the local government before a day to be specified in the notice, being a day that is not less than 6 weeks after the notice is given; and*
- (b) *as soon as the notice is given, give a copy of the proposed local law and a copy of the notice to the Minister and, if another Minister administers the Act under which the local law is proposed to be made, to that other Minister; and*
- (c) *provide a copy of the proposed local law, in accordance with the notice, to any person requesting it.*
- (3a) *A notice under subsection (3) is also to be published and exhibited as if it were a local public notice.*
- (4) *After the last day for submissions, the local government is to consider any submissions made and may make the local law* as*

proposed or make a local law that is not significantly different from what was proposed.*

**Absolute majority required.*

- (5) *After making the local law, the local government is to publish it in the Gazette and give a copy of it to the Minister and, if another Minister administers the Act under which the local law is proposed to be made, to that other Minister.*
- (6) *After the local law has been published in the Gazette the local government is to give local public notice —*
 - (a) *stating the title of the local law; and*
 - (b) *summarizing the purpose and effect of the local law (specifying the day on which it comes into operation); and*
 - (c) *advising that copies of the local law may be inspected or obtained from the local government's office.*
- (7) *The Minister may give directions to local governments requiring them to provide to the Parliament copies of local laws they have made and any explanatory or other material relating to them.*

Policy Implications

Nil.

Stakeholder Engagement / Consultation

A consultation period of six (6) weeks was held from 28th January 2017 ending on 20th March 2017.

Risk Implications

Non-compliance with the Act.

OFFICER'S COMMENT

As the 2008 local law did not meet the standards of the *Local Government Act 1995* Officers considered the document should be repealed rather than amended. A workshop was held with Councillors and staff to discuss the WALGA model local law.

During the workshop several changes were made to the model local law to reflect the circumstances and style of the Shire of Northam. The changes are listed in the below table, however as there were numerous grammatical changes, only substantial changes to the clauses will be noted.

INSERT, DELETE	CHANGES	REASON
Inserted	Clause 1.4 Definition of 'District' insert the words 'Shire of Northam'	

Deleted	Clause 1.5 Repeal- old repealed local laws	unnecessary
Inserted	Clause 1.5 Repeal - ' Standing Orders Local Law 2008 as published in the Government Gazette on 16 September 2008	
Inserted	Clause 1.6 – Provisions of the Act, Regulations and other legislation	Model Local Law
Inserted	PART 2 - Establishment and membership of committees	Model Local Law
Inserted	The relevant sections of the Act throughout the document	
Inserted	Clause 2.7 Absence from committee meetings	Model Local Law
Inserted	Clauses 2.11- 2.21	Model Local Law
Inserted	Clause 3.6 Attendance by telephone etc - Attending a meeting by telephone or other electronic media is dealt with in regulation 14A of the Regulations.	Model Local Law
Inserted	Clause 3.7 Attendance by telephone etc after natural disaster Attending a meeting by telephone or other electronic media after a natural disaster is dealt with in regulation 14B of the Regulations.	Model Local Law
Deleted	Clause 5.2 - Order of Business – items 1-15 from the Model Local Law	Model Local Law
Inserted	Clause 5.2 Order of Business – from 2008 Local law	
Deleted	Clause 6.9(3) Unless the council resolves otherwise, a deputation invited to attend a Council meeting: (a) is not to exceed 5 persons, only 2 of whom may address the Council, although others may respond to specific questions from Members; (b) is not to address the Council for a period exceeding 10 minutes without the agreement of the Council; and (c) additional members of the deputation may be allowed to speak with the leave of the Presiding Member.	Councillor changes
Delete	8.1 Members to be in their proper places (1) At the first meeting held after each election day, the CEO is to allot, alphabetically by ward, a position at the Council table to each Member. (2) Each Member is to occupy his or her allotted position at each Council meeting.	(change to old)

	8.9 Speaking twice A Member is not to address the Council more than once on any motion or amendment except: (a) as the mover of a substantive motion, to exercise a right of reply; (b) to raise a point of order; or (c) to make a personal explanation.	Change to make it clearer
Inserted	Clause 8.15(4) A member must not make a statement that a local government employee is incompetent or dishonest, either verbally or in writing.	
Inserted	Clause 9.5(2)(a) is not to be the subject of debate or comment;	
Altered	Clause 10.5 (d) moved to (e) and (e) moved to (d)	

Following the workshop with Elected Members, the below queries were raised:

- 10.14 Substantive Motion - whether the “new” motion means speakers to the “old” motion can speak again as the motion is deemed to be new, not simply amended.

Response: The CEO advised that couldn't find anywhere in Council's current standing orders which specifically supports how we have treated this 'event' in the past. However, it is understood that 10.14 is in the context of 8.9 where no member can speak more than once.

- 13.4.1(c) Method of voting - may be a show of hands. How else do we propose to vote? On the voices? –

Response: The CEO advised that if the President felt it was unanimous he could simply use the 'voices' rather than showing hands.

- 13.4.5 Divisions - should be deleted if 13.4.4 is deleted?

Response: The CEO recalls the discussion was to leave the division in, but is up to Council.

- 14.4.1 Minutes - 7 days' notice of any corrections to minutes. Seems quite tight but may simply be to ensure we all read the minutes!

Response: Mr Whiteaker advised that this matter is up to Council, however it is believed that 7 days is sufficient.



RECOMMENDATION

That Council request the CEO to provide Statewide public notice that Council intends to repeal the Shire of Northam Standing Orders Local Law 2008 and make a new Standing Orders Local Law 2017 with the following purpose and effect, in accordance with s3.12 of the *Local Government Act 1995* and invites public submissions on the proposal:

Purpose: The purpose of this local law is to provide for the orderly conduct of meetings of the council and committees, the manner of making an effective petition to the local government, and for the safe custody and use of the common seal.

Effect: The effect of this local law is that all council and committee meetings, the manner of making a petition to the local government, and the use of the common seal, are to be governed by the standing orders unless otherwise provided in the Act or regulations.

Attachment 1 (Current Local Law)

16 September 2008

GOVERNMENT GAZETTE, WA

4199

LOCAL GOVERNMENT ACT 1995

SHIRE OF NORTHAM

STANDING ORDERS LOCAL LAW 2008

TABLE OF CONTENTS

PART 1—PRELIMINARY

- 1.1 Citation
- 1.2 Definitions
- 1.3 Repeal

PART 2—APPLICATION OF STANDING ORDERS

- 2.1 Application

PART 3—MEETINGS—NOTICE OF BUSINESS

- 3.1 Notice of meetings—Members to receive notice
- 3.2 Notices of Motion—Ordinary and Extraordinary Business
- 3.3 Notice of Motion to lapse if Member not present
- 3.4 Objectionable Business
- 3.5 Business to be specified on Notice Paper

PART 4—RECORDING AND CONFIRMATION OF MINUTES

- 4.1 Minutes to be kept

PART 5—ORDINARY MEETING—ORDER OF BUSINESS

- 5.1 Order of Business
- 5.2 Late Correspondence
- 5.3 Public Question Time
- 5.4 Public Statements

PART 6—MEETINGS—PUBLIC CONDUCT

- 6.1 Admission and removal of the Public

PART 7—ROLE OF THE PRESIDENT

- 7.1 Directions by the President
- 7.2 President to take part in Debates
- 7.3 Precedence of President
- 7.4 Dissent with the President's Ruling

PART 8—CONDUCT OF MEMBERS

- 8.1 Debate—Maintenance of Order—Imputations—Offensive Expressions

PART 9—CONDUCT OF MEMBERS DURING DEBATE

- 9.1 Members to rise
- 9.2 Relevance of remarks
- 9.3 Limitation on number of Speeches
- 9.4 Limitation on duration of Speeches
- 9.5 Members not to interrupt

PART 10—PROCEDURES FOR DEBATE OF MOTIONS

- 10.1 Motions to be read
- 10.2 Motions to be Seconded
- 10.3 Only one Substantive Motion considered
- 10.4 Order of call in Debate
- 10.5 Limit of Debate
- 10.6 Seconder requesting right to speak

PART 11—PROCEDURAL MOTIONS

- 11.1 Permissible Procedural Motions
- 11.2 Reason for closure to be stated
- 11.3 Procedural Motions not required in writing
- 11.4 Procedural Motions—Recording in Minutes
- 11.5 Procedural Motions—Majority required
- 11.6 Procedural Motions—Closing Debate—Who may move
- 11.7 Procedural Motions—Right of Reply
- 11.8 Procedural Motions—Right of reply on Substantive Motion

PART 12—EFFECT OF PROCEDURAL MOTIONS

- 12.1 That the Question be now put—Effect of motion
- 12.2 That the Council move into a Committee of the Whole—Effect of motion
- 12.3 That the ruling of the President be disagreed with—Effect of motion
- 12.4 That the Motion lie on the table—Effect of Motion
- 12.5 That the Council meets behind closed doors—Effect of Motion

PART 13—DECISION MAKING PROCEDURES

- 13.1 Order of Amendments
- 13.2 Substantive Motion
- 13.3 Repetition of Motions
- 13.4 Consent of Seconder required to accept alteration of wording
- 13.5 Withdrawal of Motion and Amendments
- 13.6 Limitation of Withdrawal
- 13.7 Authority for Withdrawal
- 13.8 Right of Reply
- 13.9 Right of Reply Provisions
- 13.10 Amendments must not negate original Motion
- 13.11 Mover of Motion not to speak on Amendment
- 13.12 Question—When put
- 13.13 Question—Method of putting

PART 14—POINTS OF ORDER

- 14.1 Points of Order—When to raise—Procedure
- 14.2 Points of Order—Definitions
- 14.3 Points of Order—Ruling
- 14.4 Points of Order—Ruling conclusive, unless dissent Motion is moved
- 14.5 Points of Order—Motion against ruling procedure
- 14.6 Points of Order take precedence

PART 15—ADJOURNMENT OF MEETING

- 15.1 Meeting may be adjourned
- 15.2 Notice of adjourned meeting
- 15.3 Business at adjourned meeting
- 15.4 Limit to moving adjournment of Council
- 15.5 Unopposed business—Motion of adjournment of Council
- 15.6 Withdrawal of motion for adjournment of Council

PART 16—PERSONAL EXPLANATION

- 16.1 Personal explanation
- 16.2 Personal explanation—When heard
- 16.3 Ruling on question of personal explanation

PART 17—COMMITTEES OF COUNCIL

- 17.1 Powers and duties of Committees
- 17.2 Minutes of Committees—Numbered items
- 17.3 Reports of Committees to be taken as read
- 17.4 Procedure of report of Committees
- 17.5 Withdrawal, correction and amendments of Committees
- 17.6 Reports of Committees—Questions
- 17.7 Procedure on amendments on reports of the Committees
- 17.8 Non-related motions on reports of Committees
- 17.9 Recommendations of Committees—Inspection of Plans
- 17.10 Committee procedure
- 17.11 Rights and responsibilities of Members who are not Committee Members
- 17.12 Standing Orders to apply to Committees

PART 18—ADMINISTRATIVE MATTERS

- 18.1 Suspension of Standing Orders
- 18.2 Cases not provided for in Standing Orders
- 18.3 Enforcement of Standing Orders
- 18.4 Duty of Chief Executive Officer

PART 19—OFFENCES AND PENALTIES

- 19.1 Offences and Penalties

LOCAL GOVERNMENT ACT 1995

SHIRE OF NORTHAM

STANDING ORDERS LOCAL LAW 2008

Under the powers conferred by the *Local Government Act 1995* and under all other powers enabling it, the Council of the Shire of Northam resolved on the 23rd July 2008, to make the following local law.

PART 1—PRELIMINARY

1.1 Citation

- (1) This local law may be cited as the *Shire of Northam Standing Orders Local Law 2008*.
- (2) In the clauses to follow, this local law is referred to as "these Standing Orders".

1.2 Definitions

In these Standing Orders unless the context otherwise requires—

- "**Act**" means the *Local Government Act 1995*;
- "**CEO**" means the Chief Executive Officer of the Shire of Northam;
- "**Clause**" means a clause of these Standing Orders;
- "**Council**" means the Council of the Shire of Northam;
- "**Local government**" means the Shire of Northam;
- "**Meeting**" includes any Ordinary or Special Meeting of the Council or any other meeting held in accordance with the Act and properly convened as the Act requires;
- "**Member**" means the President or a Councillor of the Council or in the case of Committees, a member of the Committee appointed in accordance with the Act;
- "**Officer**" is an employed member of the staff of the local government;
- "**President**" includes the Deputy President, in the absence of the President and any Member chosen to preside at any meeting of the Council in accordance with the Act;
- "**Regulations**" means the *Local Government (Administration) Regulations 1996*;
- "**Absolute majority**" has the meaning given to it in the Act;
- "**Simple majority**" is more than 50% of the members present and voting.

1.3 Repeal

The following local laws are repealed—

Shire of Northam Draft Model By-law (Standing Orders) No. 4 published in the *Government Gazette* on 9 August 1974 and as amended and published in the *Government Gazette* on 15 October 1982 and 23 April 1993.

Shire of Northam Local Laws Relating to Standing Orders published in the *Government Gazette* on 1 May 1998.

Town of Northam Local Laws Relating to Standing Orders published in the *Government Gazette* on 16 January 1998.

PART 2—APPLICATION OF STANDING ORDERS

2.1 Application

All meetings of the Council or a committee and other matters as prescribed are to be conducted in accordance with the Act, the Regulations and these Standing Orders.

PART 3—MEETINGS—NOTICE OF BUSINESS

3.1 Notice of meetings—Members to Receive Notice

Notice of meetings shall be given by the CEO in accordance with the Act.

3.2 Notices of Motion—Ordinary and Extraordinary Business

(1) Members may bring forward business in the form of a written motion, notice of which shall be given in writing or electronically to the CEO, either at the meeting previous to the meeting at which it is intended to move the motion or at any time thereafter, at least two (2) working days before the publication of the Council/Committee Agenda paper.

(2) When a "Notice of Motion" is submitted to the Council/Committee meeting the Council/Committee will only vote on whether the 'Notice of Motion' should be progressed to either the next relevant Council or Committee Meeting.

(3) Other business

No other business will be conducted by Council, unless prior to the President opening the meeting, written notice has been given to each member present at the meeting or the meeting has approved, by absolute majority, the introduction of new business.

3.3 Motion to Lapse

A motion shall lapse unless the member who gave notice is present, unless another member is willing to move the motion when it is called.

3.4 Objectionable Business

If the President at any meeting of the Council is of the opinion that any motion or business proposed is of an objectionable nature, the President may, either before or at the time the matter is brought forward, declare that it shall not be considered.

3.5 Business to be Specified on Notice Paper

Any member may move dissent from such a declaration made from the Chair. On the motion being seconded, the motion to dissent shall be put without debate, and in the event of the motion being carried by a simple majority of the members present, the business referred to shall then be considered immediately, but if the motion is lost, the ruling of the President shall stand.

PART 4—RECORDING AND CONFIRMATION OF MINUTES

4.1 Minutes to be kept

Minutes are to be kept of each meeting's proceedings, confirmed or amended at the next ordinary meeting of the Council or Committee, as the case requires and signed and certified by the person presiding.

PART 5—ORDINARY MEETING—ORDER OF BUSINESS

5.1 Order of Business

The order of business of an ordinary meeting shall be as decided by the President or CEO, unless the Council resolves what the order of business shall be.

5.2 Late Business

In cases of extreme urgency or other special circumstances, late business may, with the consent of the President or at the request of a simple majority of members present be dealt with.

5.3 Public Question Time

In accordance with Section 5.24 of the Act a question time of up to thirty (30) minutes will be held as the first item of business at each ordinary meeting of Council.

5.4 Public Statements

(1) In addition to clause 5.3 members of the public may apply to address the Council on issues listed on the agenda, provided they make application to the CEO, at least twenty-four (24) hours prior to the meeting.

(2) The CEO shall provide a list of members of the public who have applied to address Council, together with the relevant agenda item number, to the President who shall determine the order in which addresses shall take place.

(3) The President may allow or refuse the application by a member of the public to make a public statement.

(4) An address by a member of the public will be limited to five (5) minutes extension of time is permissible only with the agreement of a simple majority of members present.

PART 6—MEETINGS—PUBLIC CONDUCT

6.1 Admission and Removal of the Public

(1) The public is admitted to the Council Chamber on the basis that no expression of dissent or approval, conversation or interruption to the proceedings of the Council shall take place. In the event of any such interruption, the President may use discretion and without a vote of the Council, require those interrupting to withdraw. The person or persons concerned shall immediately withdraw from the Council Chamber. This direction by the President may not be challenged by moving dissent with the ruling and the President's ruling is final.

(2) Any person, not being a member of Council, who interrupts the orderly conduct of the Council who does not withdraw immediately upon being called by the President to withdraw from the Council Chamber, may, by order of the President, be removed from the Council Chamber.

PART 7—ROLE OF THE PRESIDENT

7.1 Directions by the President

(1) At any meeting of the Council, the President shall have the right to direct attention to any matter of interest or relevance to the business of the Council or propose a change to the order of business.

(2) Any member may move that a change in order of business proposed by the President not be accepted and if carried by a simple majority of members present, the proposed change in order will not take place.

7.2 President to Take Part in Debates

Unless otherwise prohibited by the Act and Regulations, and subject to compliance with procedures for the debate of motions contained in these Standing Orders, the person presiding may take part in a discussion of any matter before the Council or committee as the case may be.

7.3 Precedence of President

When the President rises during the progress of a debate, any member then speaking, or offering to speak, shall immediately cease and every member shall preserve strict silence so that the President may be heard without interruption. This clause shall not be used by the President to exercise the right provided in Clause 7.2, but should be used to preserve order.

7.4 Dissent with the President's Ruling

Except where expressly denied in these Standing Orders or the Act and Regulations, a member may move a procedural motion to disagree with a ruling given by the President. The President must immediately call for a seconder and put the motion without debate.

PART 8—CONDUCT OF MEMBERS

8.1 Debate—Maintenance of Order—Imputations—Offensive Expressions

(1) No member at a Council or committee meeting or other organised event and members of the public are present must not, either orally or in writing or by other means—

(a) Make a statement that a local government employee is incompetent or dishonest; or

(b) Use offensive or objectionable expressions in reference to a local government employee.

(2) No member may impute motives or use offensive or objectionable expressions in reference to any member or any other person.

PART 9—CONDUCT OF MEMBERS DURING DEBATE

9.1 Members to rise

A member or officer shall stand when speaking during a Council meeting (excluding Committee meetings). This provision will not apply where a member or officer has a disability which prevents that person standing.

9.2 Relevance

Every member shall restrict their remarks to the motion or amendment under discussions, or to an explanation or point of order.

9.3 Limitation of Number of Speeches

No member shall address the Council more than once on any motion or amendment before the Council except the mover of a substantive motion, in reply, or to a point of order, or in explanation.

9.4 Limitation of Duration of Speeches

All addresses are to be limited to a maximum of five minutes. Extension of time is permissible only with the agreement of a simple majority of members present.

9.5 Members Not to Interrupt

No member is to interrupt another member whilst speaking unless—

(a) To raise a point of order;

(b) To call attention to the absence of a quorum; or

(c) To make a personal explanation under clause 16.1.

PART 10—PROCEDURES FOR DEBATE OF MOTIONS

10.1 Motions to be read

A member who intends to submit a substantive motion or amendment to a substantive motion, shall read the text before speaking to it. If a recommendation has been presented in writing and not altered, then the substantive motion may be moved as printed.

10.2 To be seconded

No motion or amendment to a substantive motion shall be in order, or be open to debate until it has been seconded except in Council Committees where clause 17.12 applies.

10.3 Only One Substantive Motion Considered

When a substantive motion is under debate at any meeting of the Council, no further substantive motion shall be accepted.

10.4 Order of Call in Debate

The President will call speakers to a substantive motion in the following order—

- (a) The mover to state the motion;
- (b) A seconder to the motion;
- (c) The mover to speak to the motion;
- (d) A speaker against the motion;
- (e) The seconder to speak to the motion;
- (f) A speaker for the motion;
- (g) Other speakers against and for the motion, alternating in view, if any;
- (h) Mover takes the right of reply which closes debate.

10.5 Limit of Debate

The President may offer the right of reply and put the motion to the vote, if the President believes sufficient discussion has taken place even though all members may not have spoken.

10.6 Secunder Requesting Right to Speak

A seconder may request the right to speak at a later time in debate, however, the moving of any procedural motion which will close debate, or any amendment to the substantive motion, will automatically deny the seconder the right to speak to the substantive motion.

PART 11—PROCEDURAL MOTIONS

11.1 Permissible Procedural Motions

In addition to proposing a properly worded amendment to the substantive motion, it is permissible for a member to move the following procedural motions—

- (a) That the question be now put;
- (b) That the Council moves into a Committee of the whole;
- (c) That the ruling of the President (or person chairing the meeting) be disagreed with;
- (d) That the motion lie on the table;
- (e) That the Council meet behind closed doors.

11.2 Reason for Closure to be Stated

A member who moves a procedural motion under clause 11.1(e) shall state the reason for moving the motion and this must relate to a matter contained in Section 5.23(2) of the Act.

11.3 Procedural Motions not Required in Writing

Procedural motions are not required to be presented in writing.

11.4 Procedural Motions—Recording in Minutes

The mover, seconder and result of all procedural motions shall be recorded in the minutes of the meeting.

11.5 Procedural Motions—Majority Required

Any procedural motion shall be carried by the simple majority of members present voting in the affirmative.

11.6 Procedural Motions—Closing Debate—Who May Move

No person who has moved, seconded or spoken for or against the substantive motion, or any amendment, may move any procedural motion which, once moved, would deny others the right to speak or, if carried, would close the debate on the substantive motion or amendment.

11.7 Procedural Motions—Right of Reply

There shall be no right of reply on any procedural motion.

11.8 Procedural Motions—Right of Reply on Substantive Motion

The carrying of a procedural motion which closes debate on the substantive motion or amendment and forces a decision on the substantive motion or amendment will not deny the right of reply, to the mover of the substantive motion.

PART 12—EFFECT OF PROCEDURAL MOTIONS

12.1 That the Question be Now Put—Effect of Motion

- (1) This motion, having been carried during discussion on a substantive motion without amendment, will cause the President to offer the right of reply and then immediately put the question under consideration without further debate.
- (2) This motion, having been carried out during discussion on an amendment, will cause the President to put the amendment to the vote without further debate.
- (3) This motion, having been lost, will allow debate to continue.

12.2 That the Council Move into a Committee of the Whole—Effect of Motion

This motion, having been carried, will allow free and open discussion on the matter before the meeting. There will be no restriction on the number of times each member may speak, provided that normal courtesy and order is maintained. Any decisions made during the time that the Council sits in Committee of the whole must be formally agreed by a substantive motion when the Council moves out of Committee of the whole.

12.3 That the Ruling of the President be Disagreed With—Effect of Motion

(1) This motion, having been carried, will cause the ruling of the President about which this motion was moved, to be reversed and for the meeting to proceed accordingly.

(2) Where the President has given a ruling, in strict accordance with the Act and Regulations, this motion may not be moved.

12.4 That the Motion Lie on the Table—Effect of Motion

(1) This motion having been carried, will cause debate on the substantive motion and any amendment to cease immediately and for the meeting to proceed to the next business.

(2) Any member may raise the motion from the table, by giving appropriate notice of motion for any meeting in the future.

(3) When a motion is raised from the table, the mover of the original substantive motion, or in the absence of the original mover, the person moving this procedural motion, is given the opportunity to reintroduce the matter, after which debate shall continue according to these Standing Orders.

12.5 That the Council Meets Behind Closed Doors—Effect of Motion

(1) This motion, if carried, causes the general public and any officer or employee the Council or committee determines, to leave the room.

(2) While a decision made under this clause is in force the operation of clause 9.3 limiting the number of speeches a member may make, is suspended unless the Council decides otherwise.

(3) Upon the public again being admitted to the meeting the person presiding, unless the Council or committee decides otherwise, is to cause the motions passed by the Council or committee whilst it was proceeding behind closed doors to be read out including the vote of a member or members to be recorded in the minutes under section 5.21 of the Act.

PART 13—DECISION MAKING PROCEDURES

13.1 Order of Amendments

Any number of amendments may be proposed to a motion, but whenever any amendment is made upon a substantive motion, no second or subsequent amendment shall be moved or considered until the first amendment has been disposed of.

13.2 Substantive Motion

If an amendment to a substantive motion is carried, the motion as amended, shall be submitted as the substantive motion and shall become the question before the Council upon which any member may speak and any further amendment may be moved.

13.3 Repetition of Motions

No motion or amendment shall be proposed which is the same in substance as a motion or amendment which has been resolved during the same sitting of Council.

13.4 Consent of Seconder Required to Accept Alteration of Wording

The mover of a substantive motion may not alter the wording of the motion without the consent of the seconder.

13.5 Withdrawal of Motion and Amendments

Council or a committee may, without debate, grant leave to withdraw a motion or amendment upon request of the mover of the motion or amendment and with the approval of the seconder provided that there is no voice expressed to the contrary view by any member, in which case discussion on the motion or amendment is to continue.

13.6 Limitation of Withdrawal

Where an amendment has been proposed to a substantive motion, the substantive motion shall not be withdrawn, except by consent of a simple majority of members present, until the amendment has been withdrawn or lost.

13.7 Authority for Withdrawal

A motion or amendment to a motion shall not be withdrawn in the absence of any member who proposed it, except with that member's written authority.

13.8 Right of Reply

(1) The mover of a substantive motion shall have the right of reply. After the mover of the substantive motion has commenced the reply, no other member shall speak on the question.

(2) The right of reply must be confined to rebutting arguments raised by previous speakers and no new matter may be introduced.

13.9 Right of Reply Provisions

The right of reply shall be governed by the following provisions—

- (a) If there is no amendment to the substantive motion, the mover may reply at the conclusion of the discussion on the motion;
- (b) If there is an amendment, the mover of the substantive motion shall take the right of reply at the conclusion of the vote on any amendments;
- (c) The mover of the amendment does not have right of reply;
- (d) Once the right of reply has been taken, there can be no further discussion, nor any other amendment and the substantive motion or the substantive motion as amended is immediately put to the vote.

13.10 Amendments Must not Negate Original Motion

No amendment to a motion can be moved which negates the original motion or the intent of the original motion.

13.11 Mover of Motion not to Speak on Amendment

On an amendment being moved, any member may speak to the amendment, except the person who moved the substantive motion who is only entitled to a right of reply except, that if the member who moved the substantive motion does choose to speak to the amendment, their right of reply is forfeited.

13.12 Question—When Put

When the debate upon any question is concluded and the right of reply has been exercised, the President shall immediately put the question to the Council, and if so desired by any member, shall again state it.

13.13 Question—Method of Putting

If a decision is not clear or in doubt, the President shall put the question as often as necessary to determine the decision from a show of hands before declaring the question.

PART 14—POINTS OF ORDER

14.1 Points of Order—When to Raise—Procedure

Upon a matter or order arising during the progress of debate, any member may raise a point of order including interrupting the speaker. A member who is speaking when a point of order is raised, shall immediately cease while the President listens to the point of order.

14.2 Points of Order—Definitions

A difference of opinion or a contradiction of a speaker, shall not be recognised as a point of order, but the following shall be recognised as valid points of order—

- (a) That the discussion is of a question not before the Council;
- (b) The offensive or insulting language is being used; or
- (c) Drawing attention to the violation of any local law or Standing Order of the Council, providing that the member raising the point of order shall state the local law or Standing Order believed to be breached.

14.3 Points of Order—Ruling

The President shall give a decision on any point of order, after the point has been raised by either upholding or rejecting the point of order.

14.4 Points of Order—Ruling Conclusive, Unless Dissent Motion is Moved

The ruling of the President upon any question of order shall be final, unless a simple majority of the members present support a motion of dissent with the ruling.

14.5 Points of Order—Motion Against Ruling Procedure

An objection having been taken to the ruling of the President, the member so objecting may immediately move dissent with the ruling. Should the motion be seconded it shall be put to the vote immediately and the result of the vote, whether in support of the ruling or otherwise, shall determine the action of the Council.

14.6 Points of Order Take Precedence

Notwithstanding anything contained in these Standing Orders to the contrary, all points of order take precedence over any other discussion and until decided, suspend the consideration and decision of every other question.

PART 15—ADJOURNMENT OF MEETING

15.1 Meeting may be Adjourned

The Council may, upon a motion moved and seconded, adjourn any meeting to a later hour of the same day or to any time not more than seven (7) days from the date of adjournment.

15.2 Notice of Adjourned Meeting

When a meeting is adjourned, if time permits, notice of the adjourned meeting shall be forwarded to each member in accordance with the Act.

16 September 2008

GOVERNMENT GAZETTE, WA

4207

15.3 Business at Adjourned Meeting

At an adjourned meeting, no additional business shall be discussed except that which was on the original notice paper for that meeting.

15.4 Limit to Moving Adjournment of Council

No member shall be allowed to move or second more than one motion of adjournment during the same sitting of the Council.

15.5 Unopposed Business—Motion for Adjournment of Council

On a motion for adjournment of the Council, the President, before putting the motion, may seek leave of the Council to proceed to the transaction of unopposed business.

15.6 Withdrawal of Motion for Adjournment of Council

A motion or an amendment relating to the adjournment of the Council may be withdrawn by the mover, with the consent of the seconder, except that if any member objects to the withdrawal, the motion must continue to be debated.

PART 16—PERSONAL EXPLANATION

16.1 Personal Explanation

No member shall speak, except upon the question before the Council, unless it is to make a personal explanation. Any member who is permitted to speak under these circumstances must confine the observations to a succinct statement of what is to be explained in relation to a specific part of the former speech which may have been misunderstood and to the explanation itself. When a member gives an explanation, that member shall make no reference to matters not strictly necessary for that purpose, nor endeavour to strengthen the former position by introducing a new argument or matter, nor reply to other members.

16.2 Personal Explanation—When Heard

A member wishing to make a personal explanation of matters referred to by any member then speaking, shall be entitled to be heard forthwith, if the member then speaking consents at the time, but if the member who is speaking declines to give way, the explanation must be offered at the conclusion of that speech.

16.3 Ruling on Questions of Personal Explanation

The ruling of the President on the admissibility of a personal explanation shall be final, unless a motion of dissent with the ruling is moved before any other business proceeds.

PART 17—COMMITTEES OF COUNCIL

17.1 Establishment and Appointment of Committees

A committee is not to be established except on a motion setting out the proposed functions of the committee and either—

- (a) The names of the members, employees and other persons to be appointed to the committee; or
- (b) The number of members, employees and other persons to be appointed to the committee and a provision that they be appointed by a separate motion.

17.2 Appointment of Deputy Committee Members

(1) The Council may appoint one or more persons to be the deputy or deputies, as the case may be, to act on behalf of a member of a committee whenever that member is unable to be present at a meeting thereof and where two or more deputies are so appointed they are to have seniority in the order determined by the Council.

(2) Where a member of a committee does not attend a meeting thereof a deputy of that member, selected according to seniority, is entitled to attend that meeting in place of the member and act for the member, and while so acting has all the powers of that member.

17.3 Reports of Committees to be Taken as Read

(1) The reports and recommendations of every Committee shall, when presented to the Council, be taken as read.

(2) The confirmation and adoption of recommendations of the Committee shall be moved by—

- (a) The Presiding Member of each Committee;
- (b) or if absent, another member of the Committee;
- (c) or if no member of the Committee is present, a member of the Council nominated by the President.

(3) It shall not be necessary to second the motion for adoption.

17.4 Procedure of Report of Committees

(1) Upon the consideration by the Council of any report or recommendations of a Committee, the President shall, without further motion, put the recommendations, in their numerical order, unless the Council shall otherwise determine.

(2) Each item adopted by the Council shall become a resolution of the Council.

17.5 Withdrawal, Correction and Amendments of Committees

(1) In moving, the adoption of a recommendation of any Committee, the mover may not propose any amendment to any recommendation, except for the correction of a verbal or clerical error.

(2) The Presiding Member of a Committee, may be excused from moving the adoption if the Presiding Member wishes to move an amendment to it. In that case, another member may move the confirmation and adoption of the recommendation.

(3) The Presiding Member or other members of a Committee bringing up a recommendation may move the confirmation and adoption of the recommendation.

17.6 Reports of Committees—Questions

When a recommendation of any Committee of the Council is submitted for confirmation and adoption, any member may direct questions directly relating to the recommendation through the President, to the Presiding Member or any member of the Committee bringing up the recommendation. No argument or speeches are permitted.

17.7 Procedure on Amendments on Reports of the Committees

When an amendment is proposed with reference to the adoption or otherwise of any recommendation of any Committee, the amendment shall be disposed of before the other proceedings of the Committee are considered.

17.8 Non-Related Motions on Reports of Committees

A member may not move any motion on any report or recommendation of any Committee which does not relate to the recommendations presented by the Committee.

17.9 Recommendations of Committees—Inspection of Plans

All plans referred to in the recommendations of the Committee that may require the consideration of the Council, shall lay on the table of the Council Chamber for the inspection of members at the meeting at which the matter is being considered.

17.10 Committee Procedure

Each Committee may, subject to the Act and Regulations, these Standing Orders and any resolution made by the Council, regulate its own procedure.

17.11 Rights and Responsibilities of Members who are not Committee Members

Members who are not members of a Committee may participate in the meeting, only at the invitation of the Presiding Member but they are not entitled to vote.

17.12 Standing Orders to Apply to Committees

These Standing Orders shall apply generally to the proceedings of Committees of the Council except that—

- (a) The requirement for members to speak only once shall not be applied in meetings of Committees;
- (b) The requirement for motions and amendments to be seconded shall not be applied in meetings of Committees;
- (c) The requirement to stand whilst speaking to a motion shall not apply, unless directed to do so by the Presiding Member.

PART 18—ADMINISTRATIVE MATTERS

18.1 Suspension of Standing Orders

- (a) The mover of a motion to suspend any Standing Order or Orders, shall state the Standing Order or Orders to be suspended and the purpose of the suspension;
- (b) A motion to suspend, temporarily, any one or more of the Standing Orders regulating the proceedings and business of the Council, must be seconded, but the motion need not be presented in writing.

18.2 Cases Not Provided for in Standing Orders

The person presiding is to decide questions of order, procedure, debate, or otherwise in cases where these Standing Orders and the Act and Regulations are silent. The decision of the person presiding in these cases is final, except where a motion is moved and carried under clause 11.1(c).

18.4 Duty of Chief Executive Officer

It is the duty of the CEO to draw the attention of the Council to any breach or likely breach of these Standing Orders, even if it requires interrupting any person speaking, including the President.

PART 19—OFFENCES AND PENALTIES

19.1 Offences and Penalties

Any contravention of this Local Law is an offence punishable in conviction by a penalty not exceeding \$5,000.00.

Dated this 23rd July 2008.

The Common Seal of the Shire of Northam is hereunto affixed by authority of a resolution of Council in the presence of—

Cr S. B. POLLARD, Shire President.

GARY P. BRENNAN, Acting Chief Executive Officer.

Attachment 2

WESTERN AUSTRALIA

Local Government Act 1995

SHIRE OF NORTHAM
Standing Orders Local Law 2017

ARRANGEMENT

Table of Contents

Part 1 - Preliminary	5
1.1 Citation	5
1.2 Commencement.....	5
1.3 Application and intent	5
1.4 Interpretation.....	5
1.5 Repeal.....	6
1.6 Provisions of the Act, Regulations and other legislation	6
Part 2 – Establishment and membership of committees	6
2.1 Establishment of committees	6
2.2 Types of committees	6
2.3 Delegation of some powers and duties to certain committees	6
2.4 Limits on delegation of powers and duties to certain committees	7
2.5 Appointment of committee members.....	7
2.6 Tenure of committee membership.....	7
2.7 Absence from committee meetings	7
2.8 Resignation of committee members	7
2.9 Register of delegations to committees	7
2.10 Committees to report.....	7
2.11 Reports of committees to be taken as read.....	7
2.12 Confirmation of committees report.....	7
2.13 Procedure of report of committees	7
2.14 Withdrawal, correction and amendments of committees	7
2.15 Reports of committees—questions.....	7
2.16 Procedure on amendments on reports of the committees.....	8
2.17 Non-related motions on reports of committees	8
2.18 Recommendations of committees—inspection of plans	8
2.19 Committee procedure.....	8
2.20 Rights and responsibilities of members who are not committee members	8
2.21 Local law applies to committees	8
Part 3 - Calling and convening meetings	8
3.1 Ordinary and special Council meetings	8
3.2 Calling council meetings.....	8
3.3 Convening council meetings	8
3.4 Calling committee meetings.....	8
3.5 Public notice of meetings	8
3.6 Attendance by Telephone etc.....	9
3.7 Attendance by telephone etc after natural disaster.....	9
Part 4 – Presiding Member and quorum.....	9
<i>Division 1: Who presides</i>	<i>9</i>
4.1 Who presides.....	9
4.2 When the Deputy President can act.....	9
4.3 Who acts if no President	9
4.4 Election of presiding members of committees.....	9
4.5 Election of deputy presiding members of committees	9
4.6 Functions of deputy presiding members	9

4.7	Who acts if no presiding member	9
	<i>Division 2 – Quorum</i>	9
4.8	Quorum for meetings	9
4.9	Reduction of quorum for Council meetings	9
4.10	Reduction of quorum for committee meetings	9
4.11	Procedure where no quorum to begin a meeting	9
4.12	Procedure where quorum not present during a meeting	9
4.13	Names to be recorded	10
Part 5	Business of a meeting	10
5.1	Business to be specified	10
5.2	Order of business	10
5.3	Motions of which previous notice has been given	10
5.4	New business of an urgent nature	11
5.5	Adoption by exception resolution	11
Part 6	Public participation	11
6.1	Meetings generally open to the public	11
6.2	Meetings not open to the public	11
6.3	Question time for the public	11
6.4	Question time for the public at certain meetings	11
6.5	Minimum question time for the public	11
6.6	Procedures for question time for the public	12
6.7	Other procedures for question time for the public	12
6.8	Distinguished visitors	12
6.9	Deputations	12
6.10	Petitions	12
6.11	Presentations	13
6.12	Participation at committee meetings	13
6.13	Council may meet to hear public submissions	13
6.14	Public Inspection of agenda materials	14
6.15	Confidentiality of information withheld	14
6.16	Recording of proceedings	14
6.17	Prevention of disturbance	14
Part 7	Questions by Members	14
Part 8	Conduct of Members	15
8.1	Members to be in their proper places	15
8.2	Respect to the Presiding Member	15
8.3	Titles to be used	15
8.4	Advice of entry or departure	15
8.5	Members to indicate their intention to speak	15
8.6	Priority of speaking	15
8.7	Presiding Member may take part in debates	15
8.8	Relevance	15
8.9	Speaking twice	16
8.10	Duration of speeches	16
8.11	No speaking after conclusion of debate	16
8.12	No interruption	16
8.13	Personal explanations	16
8.14	No reopening of discussion	16
8.15	Adverse reflection	16
8.16	Withdrawal of offensive language	17
Part 9	Preserving order	17
9.1	Presiding Member to preserve order	17
9.2	Point of order	17
9.3	Procedures on a point of order	17
9.4	Calling attention to breach	17
9.5	Ruling by the Presiding Member	17

9.6	Continued breach of order.....	17
9.7	Right of Presiding Member to adjourn.....	18
Part 10 - Debate of substantive motions.....		18
10.1	Motions to be stated and in writing.....	18
10.2	Motions to be supported.....	18
10.3	Unopposed business.....	18
10.4	Only one substantive motion at a time.....	18
10.5	Order of call in debate.....	18
10.6	Limit of debate.....	18
10.7	Member may require question to be read.....	19
10.8	Consent of seconder required for alteration.....	19
10.9	Order of amendments.....	19
10.10	Form of an amendment.....	19
10.11	Amendment must not negate original motion.....	19
10.12	Relevance of amendments.....	19
10.13	Mover of motion may speak on amendment.....	19
10.14	Effect of an amendment.....	19
10.15	Withdrawal of motion or amendment.....	19
10.16	Right of reply.....	19
Part 11 - Procedural motions.....		19
11.1	Permissible procedural motions.....	19
11.2	No debate.....	20
11.3	Who may move.....	20
11.4	Procedural motions - right of reply on substantive motion.....	20
11.5	Meeting to proceed to the next business.....	20
11.6	Debate to be adjourned.....	20
11.7	Meeting now adjourn.....	20
11.8	Question to be put.....	21
11.9	Member to be no longer heard.....	21
11.10	Ruling of the Presiding Member to be disagreed with.....	21
Part 12 - Disclosure of interests.....		21
12.1	Disclosure of interests.....	21
Part 13 - Voting.....		21
13.1	Question - when put.....	21
13.2	Voting.....	21
13.3	Majorities required for decisions.....	21
13.4	Method of taking vote.....	21
Part 14 - Minutes of meetings.....		22
14.1	Keeping of minutes.....	22
14.2	Content of minutes.....	22
14.3	Public inspection of unconfirmed minutes.....	22
14.4	Confirmation of minutes.....	22
Part 15 - Adjournment of meeting.....		22
15.1	Meeting may be adjourned.....	22
15.2	Effect of adjournment.....	22
Part 16 - Revoking or changing decisions.....		22
16.1	Requirements to revoke or change decisions.....	22
16.2	Limitations on powers to revoke or change decisions.....	22
16.3	Implementing a decision.....	23
Part 17 - Suspension of Local Laws.....		23
17.1	Suspension of Local Laws.....	23
17.2	Where Local Laws do not apply.....	23
17.3	Cases not provided for in Local Laws.....	23

Part 18 - Meetings of electors	24
18.1 Electors' general meetings.....	24
18.2 Matters for discussion at electors' general meetings.....	24
18.3 Electors' special meetings.....	24
18.4 Requests for electors' special meetings.....	24
18.5 Convening electors' meetings.....	24
18.6 Who presides at electors' meetings.....	24
18.7 Procedure for electors' meetings.....	24
18.8 Participation of non-electors.....	24
18.9 Voting at electors' meetings.....	24
18.10 Minutes of electors' meetings.....	24
18.11 Decisions made at electors' meetings.....	24
Part 19 - Enforcement	24
19.1 Penalty for breach.....	24
19.2 Who can prosecute.....	24

LOCAL GOVERNMENT ACT 1995

SHIRE OF NORTHAM

Standing Orders Local Law 2017

Under the powers conferred by the *Local Government Act 1995* and under all other relevant powers, the Shire of Northam resolved on *[INSERT DATE]* to make the following local law.

Part 1 - Preliminary

1.1 Citation

This local law may be cited as the Shire of Northam – Standing Orders Local Law 2017.

1.2 Commencement

By virtue of s3.14 of the Act, these Local Laws come into operation 14 days after the date of their publication in the *Government Gazette*.

1.3 Application and intent

- (1) These Local Laws provide rules and guidelines which apply to the conduct of meetings of the Council and its committees and to meetings of electors.
- (2) All meetings are to be conducted in accordance with the Act, the Regulations and these Local Laws.
- (3) These Local Laws are intended to result in:
 - (a) better decision-making by the Council and committees;
 - (b) the orderly conduct of meetings dealing with Council business;
 - (c) better understanding of the process of conducting meetings; and
 - (d) the more efficient and effective use of time at meetings.

1.4 Interpretation

In these Local Laws unless the context otherwise requires:

Absolute majority has the meaning given to it in s1.4 Introductory Matters of the Act;

75% majority has the meaning given to it in s1.4 Introductory Matters of the Act;

Act means the *Local Government Act 1995*;

CEO means the Chief Executive Officer of the Local Government;

Committee means a committee of the Council established under s5.8 of the Act;

Committee meeting means a meeting of a committee;

Council means the Council of the Shire of Northam;

District means the district of the Shire of Northam;

Local Government means the Shire of Northam;

President means the President of the Local Government or other Presiding Member at a Council meeting under s5.6 of the Act;

Meeting means a meeting of the Council or a committee, as the context requires;

Member has the meaning given to it in s1.4 Introductory Matters of the Act;

Presiding member means-

- (a) in respect of the Council, the person presiding under s5.6 of the Act; and
- (b) in respect of a committee, the person presiding under sections 5.12, 5.13 and 5.14 of the Act;

Regulations means the Local Government (Administration) Regulations 1996;

Simple majority means more than 50% of the members present and voting; and,

Substantive motion means an original motion or an original motion as amended, but does not include an amendment or a procedural motion.

- (2) Unless otherwise defined in these Local Laws, the terms and expressions used in these Local Laws are to have the meaning given to them in the Act and Regulations.

1.5 Repeal

The following Local Laws are repealed-

Standing Orders Local Laws 2008 as published in the *Government Gazette* on 16 September 2008

1.6 Provisions of the Act, Regulations and other legislation

- (1) Throughout these Local Laws, provisions of the Act and Regulations, and provisions of other legislation, are reproduced in a boxed format.
- (2) The purpose of reproducing these provisions is to assist the reader by giving a fuller picture of related legislative provisions that also apply to meetings of the Council, committees and electors.
- (3) The reproduced provisions of the Act and Regulations and other legislation-
 - (a) are to be treated as footnotes and are not part of these Local Laws (see section 32(2) of the *Interpretation Act 1984*); and
 - (b) reproduce only the provisions that were in force at the time that the Council resolved to adopt these Local Laws and therefore may not necessarily be correct at a future date.

Part 2 – Establishment and membership of committees

2.1 Establishment of committees

- (1) The establishment of committees is dealt with in the Act.
- (2) A Council resolution to establish a committee under s5.8 of the Act is to include-
 - (a) the terms of reference of the committee;
 - (b) the number of council members, officers and other persons to be appointed to the committee;
 - (c) the names or titles of the council members and officers to be appointed to the committee;
 - (d) the names of other persons to be appointed to the committee or an explanation of the procedure to be followed to determine the appointments; and
 - (e) details of the delegation of any powers or duties to the committee under s5.16 of the Act.
- (3) This local law is to apply to the conduct of committee meetings.

2.2 Types of committees

The types of committees are dealt with in s5.9 of the Act.

2.3 Delegation of some powers and duties to certain committees

The delegation of some powers and duties to certain committees is dealt with in s5.16 of the Act.

*Absolute Majority

- 2.4 Limits on delegation of powers and duties to certain committees**
The limits on the delegation of powers and duties to certain committees are dealt with in s5.16 of the Act. * Absolute Majority
- 2.5 Appointment of committee members**
The appointment of committee members is dealt with in s5.10 of the Act. *Absolute Majority
- 2.6 Tenure of committee membership**
Tenure of committee membership is dealt with in s5.11 of the Act.
- 2.7 Absence from committee meetings**
If any member of a committee, other than the President, is absent from three consecutive meetings without having obtained consent from the Council or committee, that member's seat on the committee will become vacant.
- 2.8 Resignation of committee members**
The resignation of committee members is dealt with in regulation 4 of the Regulations.
- 2.9 Register of delegations to committees**
The register of delegations to committees is dealt with in s5.18 of the Act.
- 2.10 Committees to report**
A committee-
- (a) is answerable to the Council; and
 - (b) is to report on its activities when, and to the extent, required by the Council.
- 2.11 Reports of committees to be taken as read**
The reports and recommendations of every committee shall, when presented to the Council be taken as read.
- 2.12 Confirmation of committees report**
The confirmation and adoption of recommendations of the committee shall be moved by-
- (a) the Chairperson of each committee;
 - (b) or if absent, another member of committee;
 - (c) if no member of committee is present, a member of the Council nominated by the President;
- and it shall not be necessary to second the motion to adopt.
- 2.13 Procedure of report of committees**
- (1) Upon the consideration by the Council or any report or recommendations of a committee, the President shall, without further motion, put the recommendations, in numerical order, unless the Council shall otherwise determine.
 - (2) Each item adopted by the Council shall become a resolution of the Council.
- 2.14 Withdrawal, correction and amendments of committees**
- (1) In moving, the adoption of a recommendation of any Committee, the mover may not propose any amendment to any recommendation, except for the correction of a verbal or clerical error.
 - (2) The Presiding Member of a committee, may be excused from moving the adoption if the Presiding Member wishes to move an amendment to it. In that case, another member of the Council may move the confirmation and adoption of the recommendation.
 - (3) The Presiding Member or other members of a committee bringing up a recommendation may move the confirmation and adoption of the recommendation.
- 2.15 Reports of committees—questions**
When a recommendation of any committee of the Council is submitted for confirmation and adoption, any member of that Council may direct questions directly relating to the recommendation-
- (a) through the President;

- (b) to the Presiding Member; or
 - (c) any member of the committee bringing up the recommendation. No argument or speeches are permitted.
- 2.16 Procedure on amendments on reports of the committees**
When an amendment is proposed with reference to the adoption or otherwise of any recommendation of any committee, the amendment shall be disposed of before the other proceedings of the committee are considered.
- 2.17 Non-related motions on reports of committees**
A Member of the Council may not move any motion on any report or recommendation of any committee which does not relate to the recommendations presented by the committee.
- 2.18 Recommendations of committees—inspection of plans**
All plans referred to in the recommendations of the committee that may require the consideration of the Council, shall lay on the table of the Council Chamber for the inspection of Members of the Council at the meeting at which the matter is being considered.
- 2.19 Committee procedure**
Each committee may, subject to the Act, these Standing Orders and any policy made by the Council, regulate its own procedure.
- 2.20 Rights and responsibilities of members who are not committee members**
Members who are not members of a committee may participate in the meeting, only at the invitation of the Presiding Member but they are not entitled to vote.
- 2.21 Local law applies to committees**
Unless otherwise specifically provided, the provisions of this local law apply generally to the proceedings of committees, except for Clause 8.1

Part 3 - Calling and convening meetings

- 3.1 Ordinary and special Council meetings**
- (1) Ordinary and special Council meetings are dealt with in s5.3 of the Act.
 - (2) An ordinary meeting of the Council, held on a monthly basis or otherwise as determined by the Council, is for the purpose of considering and dealing with the ordinary business of the Council.
 - (3) A special meeting of the Council is held for the purpose of considering and dealing with Council business that is urgent, complex in nature, for a particular purpose or confidential.
- 3.2 Calling council meetings**
The calling of Council meetings is dealt with in s5.4 of the Act.
- 3.3 Convening council meetings**
- (1) The convening of a Council meeting is dealt with in s5.5 of the Act.
 - (2) Subject to subclause (3), the CEO is to give at least 72 hours notice, for the purposes of section 5.5, in convening a special meeting of the Council.
 - (3) Where, in the opinion of the President or at least one-third of the Members, there is a need to meet urgently, the CEO may give a lesser period of notice of a special Council meeting.
- 3.4 Calling committee meetings**
The CEO is to call a meeting of any committee when requested by the President, the Presiding Member of a committee or any two members of that committee.
- 3.5 Public notice of meetings**

Public notice of meetings is dealt with in the regulation 12 of the Regulations.

- 3.6 Attendance by Telephone etc**
Attending a meeting by telephone or other electronic media is dealt with in regulation 14A of the Regulations.
- 3.7 Attendance by telephone etc after natural disaster**
Attending a meeting by telephone or other electronic media after a natural disaster is dealt with in regulation 14B of the Regulations.

Part 4 – Presiding Member and quorum

Division 1: Who presides

- 4.1 Who presides**
Who presides at a Council meeting is dealt with in s5.6 of the Act.
- 4.2 When the Deputy President can act**
When the Deputy President can act is dealt with in s5.34 of the Act.
- 4.3 Who acts if no President**
Who acts if there is no President is dealt with in s5.35 of the Act.
- 4.4 Election of presiding members of committees**
The election of Presiding Members of committees and their deputies is dealt with in s5.12 of the Act.
- 4.5 Election of deputy presiding members of committees**
The election of Deputy Presiding Members of committees is dealt with in s5.12 of the Act.
- 4.6 Functions of deputy presiding members**
The functions of Deputy Presiding Members are dealt with in s5.13 of the Act.
- 4.7 Who acts if no presiding member**
Who acts if no Presiding Member is dealt with in s5.14 of the Act.

Division 2 – Quorum

- 4.8 Quorum for meetings**
The quorum for meetings is dealt with in s5.19 of the Act.
- 4.9 Reduction of quorum for Council meetings**
The power of the Minister to reduce the number for a quorum and certain majorities is dealt with in s5.7 of the Act.
- 4.10 Reduction of quorum for committee meetings**
The reduction of a quorum for committee meetings is dealt with in s5.15 of the Act.
* Absolute Majority
- 4.11 Procedure where no quorum to begin a meeting**
The procedure where there is no quorum to begin a meeting is dealt with in regulation 8 of the Regulations.
- 4.12 Procedure where quorum not present during a meeting**
If at any time during a meeting a quorum is not present, the Presiding Member is:
(a) immediately to suspend the proceedings of the meeting for a period of up to 15 minutes; and
(b) if a quorum is not present at the expiry of that period, the Presiding Member is to adjourn the meeting to some future time or date.

4.13 Names to be recorded

At any meeting:

- (a) at which there is not a quorum present; or
 - (b) which is adjourned for want of a quorum,
- the names of the Members then present are to be recorded in the minutes.

Part 5 - Business of a meeting

5.1 Business to be specified

- (1) No business is to be transacted at any ordinary meeting of the Council other than that specified in the agenda, without the approval of the Presiding Member or the Council.
- (2) No business is to be transacted at a special meeting of the Council other than that given in the notice as the purpose of the meeting.
- (3) Subject to subclause (4), no business is to be transacted at an adjourned meeting of the Council other than that:
 - (a) specified in the notice of the meeting which had been adjourned; and
 - (b) which remains unresolved.
- (4) Where a meeting is adjourned to the next ordinary meeting of the Council then, unless the Council resolves otherwise, the business unresolved at the adjourned meeting is to be dealt with before considering Reports (Item 10) at that ordinary meeting.

5.2 Order of business

The order of business of an ordinary meeting shall be as decided by the Presiding Member or the CEO, unless the Council resolves what the order of business shall be.

- (2) Unless otherwise decided by the Council, the order of business at any special meeting of the Council is to be the order in which that business stands in the agenda of the meeting.
- (3) In determining the order of business for any meeting of the Council, the provisions of the Act and Regulations relating to the time at which public question time is to be held are to be observed. *[See section 5.24 of the Act; and regulations 6 & 7 of the Regulations]*

5.3 Motions of which previous notice has been given

- (1) Unless the Act, Regulations or these Local Laws otherwise provide, a Member may raise at a meeting such business as he or she considers appropriate, in the form of a motion, of which notice has been given in writing to the CEO and which has been included on the agenda.
- (2) A notice of motion under subclause (1) is to be given at least 7 clear working days before the meeting at which the motion is moved.
- (3) A notice of motion is to relate to the good governance of the district.
- (4) The CEO -
 - (a) may with the concurrence of the President, exclude from the notice paper any notice of motion deemed to be, or likely to involve, a breach of any of these Local Laws or any other written law;
 - (b) will inform Members on each occasion that a notice has been excluded and the reasons for that exclusion;
 - (c) may, after consultation with the Member where this is practicable, make such amendments to the form but not the substance as will bring the notice of motion into due form; and
 - (d) may provide to the Council relevant and material facts and circumstances pertaining to the notice of motion on such matters as policy, budget and law.
- (5) A motion of which notice has been given is to lapse unless-
 - (a) the Member who gave notice of it, or some other Member authorised by the originating Member in writing, moves the motion when called on; or
 - (b) the Council on a motion agrees to defer consideration of the motion to a later stage or date.
- (6) If a notice of motion is given and lapses under subclause (5), notice of a motion in the same terms or to the same effect is not to be given again for at least 3 months from the date of such lapse.

5.4 New business of an urgent nature

- (1) In cases of extreme urgency or other special circumstances, matters may, on a motion by the Presiding Member that is carried by the meeting, be raised without notice and decided by the meeting.
- (2) In subclause (1), 'cases of extreme urgency or other special circumstances' means matters that have arisen after the preparation of the agenda that are considered by the Presiding Member to be of such importance and urgency that they are unable to be dealt with administratively by the Local Government and must be considered and dealt with by the Council before the next meeting.

5.5 Adoption by exception resolution

- (1) In this clause 'adoption by exception resolution' means a resolution of the Council that has the effect of adopting, for a number of specifically identified reports, the officer recommendation as the Council resolution.
- (2) Subject to subclause (3), the Local Government may pass an adoption by exception resolution.
- (3) An adoption by exception resolution may not be used for a matter-
 - (a) that requires a 75% majority or a special majority;
 - (b) in which an interest has been disclosed;
 - (c) that has been the subject of a petition or deputation;
 - (d) that is a matter on which a Member wishes to make a statement; or
 - (e) that is a matter on which a Member wishes to move a motion that is different to the recommendation.

Part 6 - Public participation

6.1 Meetings generally open to the public

Meetings being generally open to the public is dealt with in s5.23 of the Act.

6.2 Meetings not open to the public

- (1) The CEO may, at any time, recommend that a meeting or part of a meeting be closed to members of the public.
- (2) The Council or a committee, in one or more of the circumstances dealt with in the Act, may at any time, by resolution, decide to close a meeting or part of a meeting.
- (3) If a resolution under subclause (2) is carried-
 - (a) the Presiding Member is to direct everyone to leave the meeting except:
 - (i) the Members;
 - (ii) the CEO; and
 - (iii) any Officer specified by the Presiding Member; and
 - (b) the meeting is to be closed to the public until, at the conclusion of the matter justifying the closure of the meeting to the public, the Council or the committee, by resolution, decides otherwise.
- (4) A person who fails to comply with a direction under subclause (3)(a) may, by order of the Presiding Member, be removed from the meeting.
- (5) While the resolution under subclause (2) remains in force, the operation of clause 8.9 is to be suspended until the Council or the committee, by resolution, decides otherwise.
- (6) A resolution under this clause may be made without notice.
- (7) Unless the Council resolves otherwise, once the meeting is reopened to members of the public, the Presiding Member is to ensure that any resolution of the Council made while the meeting was closed is to be read out including a vote of a Member to be included in the minutes.

6.3 Question time for the public

Question time for the public is dealt with in s5.24 of the Act.

6.4 Question time for the public at certain meetings

Question time for the public at certain meetings is dealt with in regulation 5 of the Regulations.

6.5 Minimum question time for the public

Minimum question time for the public is dealt with in regulation 6 of the Regulations.

6.6 Procedures for question time for the public

Procedures for question time for the public are dealt with in regulation 7 of the Regulations.

6.7 Other procedures for question time for the public

- (1) A member of the public who raises a question during question time, is to state his or her name and address.
- (2) A question may be taken on notice by the Council for later response.
- (3) When a question is taken on notice the CEO is to ensure that-
 - (a) a response is given to the member of the public in writing; and
 - (b) a summary of the response is included in the agenda of the next meeting of the Council.
- (4) Where a question relating to a matter in which a relevant person has an interest is directed to the relevant person, the relevant person is to-
 - (a) declare that he or she has an interest in the matter; and
 - (b) allow another person to respond to the question.
- (5) Each member of the public with a question is entitled to ask up to 2 questions before other members of the public will be invited to ask their questions.
- (6) Where a member of the public provides written questions then the Presiding Member may elect for the questions to be responded to as normal business correspondence.

- (7) The Presiding Member may decide that a public question shall not be responded to where:
 - (a) the same or similar question was asked at a previous meeting, a response was provided and the member of the public is directed to the minutes of the meeting at which the response was provided;
 - (b) the member of the public uses public question time to make a statement, provided that the Presiding Member has taken all reasonable steps to assist the member of the public to phrase the statement as a question; or
 - (c) the member of the public asks a question that is offensive or defamatory in nature, provided that the Presiding Member has taken all reasonable steps to assist the member of the public to phrase the question in a manner that is not offensive or defamatory.
- (8) A member of the public shall have two minutes to submit a question.
- (9) The Council, by resolution, may agree to extend public question time.
- (10) Where an answer to a question is given at a meeting, a summary of the question and the answer is to be included in the minutes.

6.8 Distinguished visitors

If a distinguished visitor is present at a meeting of the Council, the Presiding Member may acknowledge the presence of the distinguished visitor at an appropriate time during the meeting, and the presence of that visitor shall be recorded in the minutes.

6.9 Deputations

- (1) Any person or group wishing to be received as a deputation by the Council is to either-
 - (a) apply, before the meeting, to the CEO for approval; or
 - (b) with the approval of the Presiding Member, at the meeting, address the Council.
- (2) The CEO may either-
 - (a) approve the request and invite the deputation to attend a meeting of the Council; or
 - (b) refer the request to the Council to decide by simple majority whether or not to receive the deputation.
- (3) Any matter which is the subject of a deputation to the Council is not to be decided by the Council until the deputation has completed its presentation.

6.10 Petitions

- (1) A petition is to -
 - (a) be addressed to the President;
 - (b) be made by electors of the district;
 - (c) state the request on each page of the petition;

- (d) contain the name, address and signature of each elector making the request, and the date each elector signed;
 - (e) contain a summary of the reasons for the request; and
 - (f) state the name of the person to whom, and an address at which, notice to the petitioners can be given.
- (2) Upon receiving a petition, the Local Government is to submit the petition to the relevant officer to be included in his or her deliberations and report on the matter that is the subject of the petition, subject to subclause(3).
 - (3) At any meeting, the Council is not to vote on any matter that is the subject of a petition presented to that meeting, unless:
 - (a) the matter is the subject of a report included in the agenda; and
 - (b) the Council has considered the issues raised in the petition.

6.11 Presentations

- (1) In this clause, a "presentation" means the acceptance of a gift or an award by the Council on behalf of the Local Government or the community.
- (2) A presentation may be made to the Council at a meeting only with the prior approval of the CEO.

6.12 Participation at committee meetings

- (1) In this clause a reference to a person is to a person who-
 - (a) is entitled to attend a committee meeting;
 - (b) attends a committee meeting; and
 - (c) is not a member of that committee.

(Remove for Gazette)

A member of the public is entitled to attend a committee meeting only where a local government power or duty has been delegated to that committee: see section 5.23(1)(b) of the Act.

- (2) Without the consent of the Presiding Member, no person is to address a committee meeting.
- (3) The Presiding Member of a committee may allow a person to make an oral submission to the committee for up to 3 minutes.
- (4) A person addressing the committee with the consent of the Presiding Member is to cease that address immediately after being directed to do so by the Presiding Member.
- (5) A person who fails to comply with a direction of the Presiding Member under subclause (4) may, by order of the Presiding Member, be removed from the committee room.
- (6) The Council may make a policy dealing with the circumstances in which a person may be given consent to address a committee meeting.

6.13 Council may meet to hear public submissions

- (1) Where an item on the agenda at a Council meeting is contentious and is likely be the subject of a number of deputations, the Council may resolve to meet at another time to provide a greater opportunity to be heard.
- (2) The CEO and the President shall set the time and date of the meeting to provide the opportunity to be heard.
- (3) Where the Council resolves to meet to provide the opportunity to be heard under subclause (1), the Presiding Member shall-
 - (a) instruct the CEO to provide local public notice of the time and date when the Council will meet to provide an opportunity to be heard;
 - (b) provide a written invitation to attend the meeting to provide the opportunity to be heard to all members of the public who have applied under clause 6.9 to make a deputation on the issue; and
 - (c) cause minutes to be kept of the meeting to provide the opportunity to be heard.
- (4) A meeting held under subclause (1) shall be conducted only to hear submissions. The council shall not make resolutions at a meeting to provide the opportunity to be heard.
- (5) At a meeting held under subclause (1), each person making a submission shall be provided with the opportunity to fully state his or her case.

- (6) A member of the public shall be limited to 10 minutes in making an oral submission, but this period may be extended at the discretion of the Presiding Member.
- (7) Once every member of the public has had the opportunity to make a submission the Presiding Member is to close the meeting.
- (8) The CEO is to ensure that a report is included on the agenda of the next Council meeting summarising each submission made at the meeting.
- (9) The Council must not resolve on the matter that is the subject of a meeting to provide the opportunity to be heard until it has received the CEO's report under subclause (8).

6.14 Public Inspection of agenda materials

The right of the public to inspect the documents referred to, and in accordance with, regulation 14 of the Regulations may be exercised at the Shire of Northam and on the Local Government's website.

6.15 Confidentiality of information withheld

- (1) Information withheld by the CEO from the public under regulation 14(2) of the Regulations is to be-
 - (a) identified in the agenda of a Council meeting under the item "Matters for which meeting may be closed";
 - (b) marked "*Confidential*" in the agenda; and
 - (c) kept confidential by Officers and Members until the Council resolves otherwise.
- (2) A member or an officer in receipt of confidential information under subclause (1) or information that is provided or disclosed during a meeting or part of a meeting that is closed to the public is not to disclose any of that information to any person other than another member or an officer to the extent necessary for the purpose of carrying out his or her duties.
- (3) Subclause (2) does not apply where a member or officer discloses the information to his or her lawyer or government officer for the purpose of seeking advice in order to lawfully fulfil his or her role and responsibilities.

6.16 Recording of proceedings

- (1) A person is not to use any electronic, visual or audio recording device or instrument to record the proceedings of the Council without the permission of the Presiding Member.
- (2) If the Presiding Member gives permission under subclause (1), the Presiding Member is to advise the meeting, immediately before the recording is commenced, that such permission has been given and the nature and extent of that permission.

6.17 Prevention of disturbance

- (1) A reference in this clause to a person is to a person other than a member.
- (2) A person addressing the Council shall extend due courtesy and respect to the Council and the processes under which it operates and shall comply with any direction by the Presiding Member.
- (3) A person observing a meeting shall not create a disturbance at a meeting, by interrupting or interfering with the proceedings, whether by expressing approval or dissent, by conversing or by any other means.
- (4) A person shall ensure that his or her mobile telephone or pager is not audible during any meeting of the Council.
- (5) A person shall not behave in a manner that is contrary to the *Criminal Code*.

Part 7 - Questions by Members

- 7.1 (1) Members may ask questions relating to an item on the notice paper or on matters related to the good government of persons in the district.
- (2) A Member requesting general information from an Officer at a Council meeting may ask a question without notice and with the consent of the Presiding Member, may ask one or more further questions of that Officer or another Officer present at the meeting.
- (3) Where possible the Officer shall endeavour to answer the question to the best of his or her

- knowledge and ability, however, if the information is unavailable or the answer requires research or investigation, the Officer may ask that -
- (a) the question be placed on notice for the next meeting of Council; and
 - (b) the answer to the question be given to the Member who asked it within 14 days.
- (4) Every question and answer -
- (a) is to be brief and concise; and
 - (b) is not to be accompanied by argument, expression of opinion or statement of facts, except to the extent necessary to explain the question or answer.
- (5) In answering any question, an Officer may qualify his or her answer and may at a later time in the meeting or at a subsequent meeting alter, correct, add to or otherwise amend the original answer.

Part 8 – Conduct of Members

8.1 Members to be in their proper places

- (1) At the first meeting held after each election day, the CEO is to allot a position at the Council table to each Member.
- (2) Each Member is to occupy his or her allotted position at each Council meeting.

8.2 Respect to the Presiding Member

After the business of a Council has been commenced, a Member is not to enter or leave the meeting without first paying due respect to the Presiding Member.

8.3 Titles to be used

A speaker, when referring to the President, Deputy President or Presiding Member, or a Member or Officer, is to use the title of that person's office.

8.4 Advice of entry or departure

During the course of a meeting of the Council, a Member is not to enter or leave the meeting without first advising the Presiding Member, in order to facilitate the recording in the minutes of the time of entry or departure.

8.5 Members to indicate their intention to speak

A Member of the Council who wishes to speak is to indicate his or her intention to speak by raising his or her hand and must stand when speaking at council meetings (excluding committee meetings.) Standing is not required for a member who has an impairment which excludes his/her ability to stand.

8.6 Priority of speaking

- (1) Where two or more Members indicate, at the same time, their intention to speak, the Presiding Member is to decide which Member is entitled to be heard first.
- (2) A decision of the Presiding Member under subclause (1) is not open to discussion or dissent.
- (3) A Member is to cease speaking immediately after being asked to do so by the Presiding Member.

8.7 Presiding Member may take part in debates

The Presiding Member may take part in a discussion of any matter before the Council, subject to compliance with these Local Laws.

8.8 Relevance

- (1) A Member is to restrict his or her remarks to the motion or amendment under discussion, or to a personal explanation or point of order.
- (2) The Presiding Member, at any time, may-
 - (a) call the attention of the meeting to:
 - (i) any irrelevant, repetitious, offensive or insulting language by a Member; or
 - (ii) any breach of order by a Member; and

- (b) direct that Member, if speaking, to discontinue his or her speech.
- (3) A Member is to comply with the direction of the Presiding Member under subclause (2) by immediately ceasing to speak.

8.9 Speaking twice

A Member may address the Council more than once on any motion or amendment:

- (a) as the mover of a substantive motion, to exercise a right of reply;
- (b) to raise a point of order; or
- (c) to make a personal explanation.

8.10 Duration of speeches

- (1) A Member is not to speak on any matter for more than 5 minutes without the consent of the Council which, if given, is to be given without debate.
- (2) An extension under this clause cannot be given to allow a Member's total speaking time to exceed 10 minutes.

8.11 No speaking after conclusion of debate

A Member is not to speak on any motion or amendment-

- (a) after the mover has replied; or
- (b) after the question has been put.

8.12 No interruption

A Member is not to interrupt another Member who is speaking unless-

- (a) to raise a point of order;
- (b) to call attention to the absence of a quorum;
- (c) to make a personal explanation under clause 8.13; or
- (d) to move a procedural motion that the Member be no longer heard.

8.13 Personal explanations

- (1) A Member who wishes to make a personal explanation relating to a matter referred to by another Member who is then speaking is to indicate to the Presiding Member his or her intention to make a personal explanation.
- (2) The Presiding Member is to determine whether the personal explanation is to be heard immediately or at the conclusion of the speech by the other Member.
- (3) A Member making a personal explanation is to confine his or her observations to a succinct statement relating to a specific part of the speech at which he or she may have been misunderstood.

8.14 No reopening of discussion

A Member is not to reopen discussion on any Council decision, except to move that the decision be revoked or changed.

8.15 Adverse reflection

- (1) A Member is not to reflect adversely on a decision of the Council except on a motion that the decision be revoked or changed .
- (2) A Member is not:
 - (a) to reflect adversely on the character or actions of another Member or Officer; or
 - (b) to impute any motive to a Member or Officer, unless the meeting resolves, without debate, that the question then before the meeting cannot otherwise be adequately considered.
- (3) A Member is not to use offensive expressions in reference to any Member, Officer or other person.
- (4) A member must not make a statement that a local government employee is incompetent or dishonest, either verbally or in writing.
- (5) If a Member specifically requests, immediately after their use, that any particular words used by a Member be recorded in the minutes:
 - (a) the Presiding Member is to cause the words used to be taken down and read to the meeting for verification; and
 - (b) the Council may, by resolution, decide to record those words in the minutes.

8.16 Withdrawal of offensive language

- (1) A Member who, in the opinion of the Presiding Member, uses an expression which:
 - (a) in the absence of a resolution under clause 8.15-
 - (i) reflects adversely on the character or actions of another Member or Officer; or
 - (ii) imputes any motive to a Member or Officer; or
 - (b) is offensive or insulting, must, when directed by the Presiding Member, withdraw the expression and make a satisfactory apology.
- (2) If a Member fails to comply with a direction of the Presiding Member under subclause (1), the Presiding Member may refuse to hear the Member further on the matter then under discussion and call on the next speaker.

Part 9 - Preserving order

9.1 Presiding Member to preserve order

- (1) The Presiding Member is to preserve order, and, whenever he or she considers necessary, may call any Member to order.
- (2) When the Presiding Member speaks during a debate, any Member then speaking, or indicating that he or she wishes to speak, is immediately to sit down and every Member present is to preserve strict silence so that the Presiding Member may be heard without interruption.
- (3) Subclause (2) is not to be used by the Presiding Member to exercise the right provided in clause 8.7, but to preserve order.

9.2 Point of order

- (1) A Member may object, by way of a point of order, only to a breach of-
 - (a) any of these Local Laws; or
 - (b) any other written law.
- (2) Despite anything in these Local Laws to the contrary, a point of order:
 - (a) takes precedence over any discussion; and
 - (b) until determined, suspends the consideration or discussion of any other matter.

9.3 Procedures on a point of order

- (1) A Member who is addressing the Presiding Member is not to be interrupted except on a point of order.
- (2) A Member interrupted on a point of order is to resume his or her seat until-
 - (a) the Member raising the point of order has been heard; and
 - (b) the Presiding Member has ruled on the point of order,and, if permitted, the Member who has been interrupted may then proceed.

9.4 Calling attention to breach

A Member may, at any time, draw the attention of the Presiding Member to any breach of these Local Laws.

9.5 Ruling by the Presiding Member

- (1) The Presiding Member is to rule on any point of order which is raised by either upholding or rejecting the point of order.
- (2) A ruling by the Presiding Member on a point of order is to be final unless the majority of members present and voting, on a motion moved immediately after the ruling, dissent from the ruling.
- (3) Subject to a motion of dissent being carried under subclause (2), if the Presiding Member rules that:
 - (a) any motion, amendment or other matter before the meeting is out of order, it is not to be considered further; and
 - (b) a statement made or act done by a Member is out of order, the Presiding Member may require the Member to make an explanation, retraction or apology.

9.6 Continued breach of order

If a Member:

- (a) persists in any conduct that the Presiding Member had ruled is out of order; or
- (b) refuses to make an explanation, retraction or apology required by the Presiding Member under clause 9.5(3), the Presiding Member may direct the Member to refrain from taking any further part in the matter under discussion, other than by voting, and the Member is to comply with that direction.

9.7 Right of Presiding Member to adjourn

- (1) For the purpose of preserving or regaining order, the Presiding Member may adjourn the meeting for a period of up to 15 minutes.
- (2) On resumption, the debate is to continue at the point at which the meeting was adjourned.
- (3) If, at any one meeting, the Presiding Member adjourns the meeting more than once for the purpose of preserving or regaining order, the second or subsequent adjournment may be to a later time on the same day or to another day.

Part 10 - Debate of substantive motions

10.1 Motions to be stated and in writing

Any Member who wishes to move a substantive motion or an amendment to a substantive motion:

- (a) is to state the substance of the motion before speaking to it; and
- (b) if required by the Presiding Member, is to put the motion or amendment in writing.

10.2 Motions to be supported

- (1) A substantive motion or an amendment to a substantive motion is not open to debate until it has been seconded.
- (2) A motion to revoke or change a decision made at a Council meeting is not open to debate unless the motion has the support required under regulation 10 of the Regulations.

10.3 Unopposed business

- (1) Immediately after a substantive motion has been moved and seconded, the Presiding Member may ask the meeting if any Member opposes it.
- (2) If no Member opposes the motion, the Presiding Member may declare it carried without debate and without taking a vote.
- (3) A motion declared carried under this clause is to be recorded in the minutes as a unanimous decision of the Council.
- (4) If a Member opposes a motion, the motion is to be dealt with under this Part.
- (5) This clause does not apply to a motion to revoke or change a decision which has been made at a Council meeting.

10.4 Only one substantive motion at a time

When a substantive motion is under debate at a meeting of the Council, no further substantive motion is to be accepted. The Council is not to consider more than one substantive motion at any time.

10.5 Order of call in debate

The Presiding Member is to call speakers to a substantive motion in the following order:

- (a) the mover to state the motion;
- (b) a seconder to the motion;
- (c) the mover to speak to the motion;
- (d) a speaker against the motion;
- (e) the seconder to speak to the motion;
- (f) a speaker for the motion;
- (g) other speakers against and for the motion, alternating in view where possible; and
- (h) mover takes right of reply which closes debate.

10.6 Limit of debate

The Presiding Member may offer the right of reply and put a substantive motion to the vote if he or she believes that sufficient discussion has taken place even though all Members may not have spoken.

- 10.7 Member may require question to be read**
A Member may require the question or matter under discussion to be read at any time during a debate, but not so as to interrupt any other Member who is speaking.
- 10.8 Consent of seconder required for alteration**
The mover of a substantive motion may not alter the wording of the motion without the consent of the seconder.
- 10.9 Order of amendments**
Any number of amendments may be proposed to a substantive motion, but when an amendment is moved to a substantive motion, no second or subsequent amendment is to be moved or considered until the first amendment has been withdrawn, carried or lost.
- 10.10 Form of an amendment**
An amendment must add, delete, or substitute words to the substantive motion.
- 10.11 Amendment must not negate original motion**
An amendment to a substantive motion cannot negate the original motion or the intent of the original motion.
- 10.12 Relevance of amendments**
Each amendment is to be relevant to the motion in respect of which it is moved.
- 10.13 Mover of motion may speak on amendment**
Any Member may speak during debate on an amendment.
- 10.14 Effect of an amendment**
If an amendment to a substantive motion is carried, the motion as amended then becomes the substantive motion, on which any Member may speak and any further amendment may be moved.
- 10.15 Withdrawal of motion or amendment**
- (1) Subject to subclause (2), the Council may, without debate, grant leave to withdraw a motion or amendment on the request of the mover of the motion or amendment and with the approval of the seconder.
 - (2) Where an amendment has been proposed to a substantive motion, the substantive motion is not to be withdrawn, except by consent of the majority of Members present, until the amendment proposed has been withdrawn or lost.
- 10.16 Right of reply**
- (1) The mover of a substantive motion has the right of reply.
 - (2) The mover of any amendment to a substantive motion has a right of reply.
 - (3) The right of the reply may only be exercised:
 - (a) where no amendment is moved to the substantive motion – at the conclusion of the discussion on the motion; or
 - (b) where one or more amendments have been moved to the substantive motion – at the conclusion of the discussion on the substantive motion and any amendments.
 - (4) After the mover of the substantive motion has commenced the reply:
 - (a) no other Member is to speak on the question;
 - (b) there is to be no further discussion on, or any further amendment to, the motion.
 - (5) The right of the reply is to be confined to rebutting arguments raised by previous speakers and no new matter is to be introduced.
 - (6) At the conclusion of the right of reply, the substantive motion, or the substantive motion as amended, is immediately to be put to the vote.

Part 11 - Procedural motions

11.1 Permissible procedural motions

In addition to the right to move an amendment to a substantive motion a Member may move the following procedural motions:

- (a) that the meeting proceed to the next item of business;
- (b) that the debate be adjourned;
- (c) that the meeting now adjourn;
- (d) that the question be now put;
- (e) that the Member be no longer heard;
- (f) that the ruling of the Presiding Member be disagreed with;
- (g) that the Standing Orders clause... be suspended;
- (h) that the Standing Orders be resumed;
- (i) that the meeting be closed to the public (see clause 6.2).
- (j) that the motion lie on the table

11.2 No debate

- (1) The mover of a motion specified in paragraph (a), (b), (c), (f) or (g) of clause 11.1 may speak to the motion for not more than five minutes, the seconder is not to speak other than to formally second the motion, and there is to be no debate on the motion.
- (2) The mover of a motion specified in paragraph (d) or (e) of clause 11.1 may not speak to the motion, the seconder is not to speak other than to formally second the motion, and there is to be no debate on the motion.

11.3 Who may move

No person who has moved, seconded, or spoken for or against the substantive motion, or any amendment to the substantive motion, may move any procedural motion which, if carried, would close the debate on the substantive motion or amendment.

11.4 Procedural motions - right of reply on substantive motion

The carrying of a procedural motion which closes debate on the substantive motion or amendment and forces a decision on the substantive motion or amendment does not deny the right of reply to the mover of the substantive motion.

11.5 Meeting to proceed to the next business

The motion "that the meeting proceed to the next business", if carried, has the effect that:

- (a) the debate on the substantive motion or amendment ceases immediately;
- (b) no decision is made on the substantive motion;
- (c) the Council moves to the next item of business; and
- (d) there is no requirement for the matter to be raised again for consideration.

11.6 Debate to be adjourned

A motion "that the debate be adjourned":

- (a) is to state the time to which the debate is to be adjourned; and
- (b) if carried, has the effect that all debate on the substantive motion or amendment ceases immediately, but continues at the time stated in the motion.

11.7 Meeting now adjourn

- (1) A Member is not to move or second more than one motion of adjournment during the same sitting of the Council.
- (2) Before putting the motion for the adjournment of the Council, the Presiding Member may seek leave of the Council to deal first with matters that may be the subject of an adoption by exception resolution.
- (3) A motion "that the meeting now adjourn":
 - (a) is to state the time and date to which the meeting is to be adjourned; and
 - (b) if carried, has the effect that the meeting is adjourned to the time and date specified in the motion.
- (4) A meeting adjourned under subclause (3) is to continue from the point at which it was adjourned, unless the Presiding Member or the Council determines otherwise.

11.8 Question to be put

- (1) If the motion "that the question be now put", is carried during debate on a substantive motion without amendment, the Presiding Member is to offer the right of reply and then put the motion to the vote without further debate.
- (2) If the motion "that the question be now put" is carried during discussion of an amendment, the Presiding Member is to put the amendment to the vote without further debate.
- (3) This motion, if lost, causes debate to continue.

11.9 Member to be no longer heard

If the motion "that the member be no longer heard", is carried, the speaker against whom the motion has been moved cannot speak further on the current substantive motion, or any amendment relating to it, except to exercise the right of reply if he or she is the mover of the substantive motion.

11.10 Ruling of the Presiding Member to be disagreed with

If the motion "that the ruling of the Presiding Member be disagreed with", is carried, that ruling is to have no effect and the meeting is to proceed accordingly.

Part 12 - Disclosure of interests

12.1 Disclosure of interests

Disclosure of interests is dealt with in Part 5 Division 6 of the Act.

Part 13 - Voting

13.1 Question - when put

- (1) Immediately after the debate on any question is concluded and the right of reply has been exercised, the Presiding Member -
 - (a) is to put the question to the Council; and
 - (b) if requested by any Member, is to again state the terms of the question.
- (2) A Member is not to leave the meeting when the Presiding Member is putting any question.

13.2 Voting

Voting is dealt with in s5.21 of the Act and the Regulations.

13.3 Majorities required for decisions

The majorities required for decisions of the Council and committees are dealt with in the Act.

13.4 Method of taking vote

- (1) In taking the vote on any motion or amendment the Presiding Member:
 - (a) is to put the question, first in the affirmative, and then in the negative;
 - (b) may put the question in this way as often as may be necessary to enable him or her to determine whether the affirmative or the negative has the majority of votes;
 - (c) may accept a vote on the show of hands; and,
 - (d) is subject to this clause to declare the result.
- (2) If a Member calls for a show of hands, the result of the vote is to be determined on the count of raised hands.
- (3) If a member of council or a committee specifically requests that there be recorded -
 - (a) his or her vote; or,
 - (b) the vote of all members present on a matter voted on at a meeting of the council or committee, the person presiding is to cause the vote or votes, as the case may be, to be recorded in the minutes.
- (4) If a Member calls for a division:
 - (a) those voting in the affirmative are to pass to the right of the Chair; and
 - (b) those voting in the negative are to pass to the left of the Chair.
- (5) For every division, the CEO is to record:
 - (a) the name of each member who voted; and

- (b) whether he or she voted in the affirmative or negative.

Part 14 – Minutes of meetings

14.1 Keeping of minutes

The keeping and confirmation of minutes are dealt with in s5.22 of the Act.

14.2 Content of minutes

- (1) The content of minutes is dealt with in regulation 11 of the Regulations.
- (2) In addition to the matters required by regulation 11, the minutes of a Council meeting is to include, where an application for approval is refused or the authorisation of a licence, permit or certificate is withheld or cancelled, the reasons for the decision.

14.3 Public inspection of unconfirmed minutes

The public inspection of unconfirmed minutes is dealt with in regulation 13 of the Regulations.

14.4 Confirmation of minutes

- (1) When minutes of an ordinary meeting of the Council are distributed for consideration prior to their confirmation at the next meeting, if a Member is dissatisfied with the accuracy of the minutes, the Member may provide the Local Government with a written copy of the alternative wording to amend the minutes no later than 7 clear working days before the next ordinary meeting of the Council.
- (2) At the next ordinary meeting of the Council, the Member who provided the alternative wording shall, at the time for confirmation of minutes –
 - (a) state the item or items with which he or she is dissatisfied; and
 - (b) propose a motion clearly outlining the alternative wording to amend the minutes.
- (3) Members must not discuss items of business contained in the minutes, other than discussion as to their accuracy as a record of the proceedings.

Part 15 - Adjournment of meeting

15.1 Meeting may be adjourned

The Council may adjourn any meeting:

- (a) to a later time on the same day; or
- (b) to any other time on any other day, including a time which coincides with the conclusion of another meeting or event.

15.2 Effect of adjournment

Where any matter, motion, debate or meeting is adjourned under these Local Laws:

- (a) the names of Members who have spoken on the matter prior to the adjournment are to be recorded in the minutes;
- (b) debate is to be resumed at the next meeting at the point where it was interrupted; and
- (c) the provisions of clause 8.9 [speaking twice] apply when the debate is resumed.

Part 16 – Revoking or changing decisions

16.1 Requirements to revoke or change decisions

The requirements to revoke or change a decision made at a meeting are dealt with in regulation 10 of the Regulations.

16.2 Limitations on powers to revoke or change decisions

- (1) Subject to subclause (2), the Council or a committee is not to consider a motion to revoke or change a decision:
 - (a) where, at the time the motion is moved or notice is given, any action has been taken under clause 16.3 to implement the decision; or
 - (b) where the decision is procedural in its form or effect.

- (2) The Council or a committee may consider a motion to revoke or change a decision of the kind described in subclause (1)(a) if the motion is accompanied by a written statement of the legal and financial consequences of carrying the motion.

16.3 Implementing a decision

- (1) In this clause-
 - (a) "authorisation" means a licence, permit, approval or other means of authorising a person to do anything;
 - (b) "implement", in relation to a decision, includes:
 - (i) communicate notice of the decision to a person affected by, or with an interest in, the decision; and
 - (ii) take any other action to give effect to the decision; and
 - (c) "valid notice of revocation motion" means a notice of motion to revoke or change a decision that complies with the requirements of the Act, Regulations and the Local Laws and may be considered, but has not yet been considered, by the Council or a committee as the case may be.
- (2) Subject to subclause (4), and unless a resolution is made under subclause (3), a decision made at a meeting is not to be implemented by the CEO or any other person until the afternoon of the first business day after the commencement of the meeting at which the decision was made.
- (3) The Council or a committee may, by resolution carried at the same meeting at which a decision was made, direct the CEO or another person to take immediate action to implement the decision.
- (4) A decision made at a meeting is not to be implemented by the CEO or any other person:
 - (a) if, before commencing any implementation action, the CEO or that person is given a valid notice of revocation motion; and
 - (b) unless and until the valid notice of revocation motion has been determined by the Council or the committee as the case may be.
- (5) The CEO is to ensure that members of the public attending the meeting are informed by an appropriate notice that a decision to grant an authorisation:
 - (a) is to take effect only in accordance with this clause; and
 - (b) cannot be acted upon by the person who has been granted the authorisation unless and until the decision has been implemented in accordance with this clause.

Part 17 - Suspension of Local Laws

17.1 Suspension of Local Laws

- (1) A Member may at any time move that the operation of one or more of the provisions of these Local Laws be suspended and nominate which clause they wish to suspend.
- (2) A Member moving a motion under subclause (1) is to state the reasons for the motion, but no other discussion is to take place.
- (3) A motion under subclause (1) which is:
 - (a) seconded; and
 - (b) carried by an absolute majority, is to suspend the operation of the clause or clauses to which the motion relates for the duration of the meeting, unless the meeting earlier resolves otherwise.

17.2 Where Local Laws do not apply

- (1) In situations where-
 - (a) one or more provisions of these Local Laws have been suspended;
 - or
 - (b) a matter is not regulated by the Act, the Regulations or this local law, the Presiding Member is to decide questions relating to the conduct of the meeting.
- (2) The decision of the Presiding Member under subclause (1) is final, except where a motion is moved and carried under clause 11.10.

17.3 Cases not provided for in Local Laws

The Presiding Member is to decide questions of order, procedure, debate, or otherwise in cases where these Local Laws, the Act or the Regulations are silent. The decision of the Presiding Member in these cases is final, except where a motion is moved and carried under clause 11.10.

Part 18 - Meetings of electors

- 18.1 Electors' general meetings**
Electors' general meetings are dealt with in s5.27 of the Act.
- 18.2 Matters for discussion at electors' general meetings**
The matters to be discussed at electors' general meetings are dealt with in Regulation 15 of the Regulations.
- 18.3 Electors' special meetings**
Electors' special meetings are dealt with in s5.28 of the Act.
- 18.4 Requests for electors' special meetings**
Requests for electors' special meetings are dealt with in regulation 16 of the Regulations.
- 18.5 Convening electors' meetings**
Convening electors' meetings is dealt with in s5.29 of the Act.
- 18.6 Who presides at electors' meetings**
Who presides at electors' meetings is dealt with in s5.30 of the Act.
- 18.7 Procedure for electors' meetings**
(1) The procedure for electors' meetings is dealt with in s5.31 of the Act and regulation 18 of the Regulations.
(2) In exercising his or her discretion to determine the procedure to be followed at an electors' meeting, the Presiding Member is to have regard to these Local Laws.
- 18.8 Participation of non-electors**
A person who is not an elector of the Local Government shall not take part in any discussion at an electors' meeting unless the meeting, by resolution, permits the person do so.
- 18.9 Voting at electors' meetings**
Voting at electors' meetings is dealt with in Regulation 17 of the Regulations.
- 18.10 Minutes of electors' meetings**
Minutes of electors' meetings are dealt with in s5.32 of the Act.
- 18.11 Decisions made at electors' meetings**
Decisions made at electors' meetings are dealt with in s5.33 of the Act.

Part 19 - Enforcement

- 19.1 Penalty for breach**
A person who breaches a provision of these Local Laws commits an offence.
Penalty: \$5,000.00 where the offence is of a continuing nature a daily penalty of **\$500.00** in respect of each day or part day during which the offence has continued.
- 19.2 Who can prosecute**
Who can prosecute is dealt with in the Act.

Dated: **[INSERT DATE]**

The Common Seal of the SHIRE OF NORTHAM
was affixed by the authority of
a resolution of Council in the presence of:

CR CHRISTOPHER ANTONIO
President

JASON WHITEAKER
Chief Executive Officer

12.4.6 Write off Rates Debt for Hangar 8, Northam Airport

Address:	105 Withers Street Northam
Owner:	Shire of Northam/Richard Wiltshire
File Reference:	A15582 & A15583
Reporting Officer:	Cheryl Greenough Governance
Responsible Officer:	Colin Young Executive Manager Corporate Services
Voting Requirement	Simple Majority

BRIEF

This report is to request that Council write off a debt of \$4,296.34 owing by Mr Wiltshire.

ATTACHMENTS

Attachment 1: Nil.

BACKGROUND / DETAILS

In 2014, Mr Wiltshire leased two hangar blocks with the purpose of building one large hangar over the two sites and amalgamating them into one large hangar lot.

The lease agreement entered into was based on the lots being amalgamated and rated as one lot, however this arrangement was never implemented with Mr Wiltshire being charged two separate rates. However, Mr Wiltshire has only been paying one set of rates in accordance with the terms of the lease arrangement.

CONSIDERATIONS

Strategic Community / Corporate Business Plan
Theme Area 5: Infrastructure & Service Delivery.

Outcome 5.3: To have safe, well-maintained community infrastructure and services to a standard expected of a Regional Centre.

- Improve and encourage utilisation of existing airport facilities and associated air services.

Financial / Resource Implications

Council will be required to write off \$4,296.34 in accrued rates.

Legislative Compliance

Section 6.12, Local Government Act 1995, Power to defer, grant discounts, waive or write off debts

- (1) *Subject to subsection (2) and any other written law, a local government may —*
- (a) *when adopting the annual budget, grant* a discount or other incentive for the early payment of any amount of money; or*
 - (b) *waive or grant concessions in relation to any amount of money; or*
 - (c) *write off any amount of money, which is owed to the local government.*

** Absolute majority required.*

- (2) *Subsection (1)(a) and (b) do not apply to an amount of money owing in respect of rates and service charges.*
- (3) *The grant of a concession under subsection (1)(b) may be subject to any conditions determined by the local government. (4) Regulations may prescribe circumstances in which a local government is not to exercise a power under subsection (1) or regulate the exercise of that power.*

Policy Implications

Policy A8.5(3) Management of Council Property Leases

3.0 Airport Hangar Site Agreement:

- 3.1. The Shire has an expectation that it will receive a rent calculated on the land use or probable use rate at a set rate per square metre determined by the Valuer General; or
- 3.2. No less than market value of vacant land determined by the Valuer General for any lease area or licence.
- 3.3. Lessee or Licensee will be responsible to contribute to the full cost of any previous improvements to the Airport by way of a levy proportioned to the cost of the work by a once-off lease “establishment fee” or “transfer fee”.
- 3.4. All agreements will have a common expiry date and an option to renew shall be limited to no more than five years.
- 3.5. The Lessee or Licensee will be responsible for meeting the full cost of the document preparation, registration and other costs associated with the execution of the agreement.
- 3.6. All improvements, repairs and maintenance to the “Demised Premises” are the sole responsibility of the Lessee or Licensee.
- 3.7. The Lessee or Licensee will be responsible for building and contents and also hold current public liability insurance and worker compensation (if applicable) to the value stipulated in the agreement.

Stakeholder Engagement / Consultation

Nil.

Risk Implications

Legal action may be required to recover the outstanding rates resulting in poor public perception.

OFFICER'S COMMENT

Mr Wiltshire currently leases lot 7 & 8 which are both 15mtr x 12mtrs giving a combined 30mtrs x 12mtrs. The combined lease fee that he is paying is \$1,364.34 per annum. This lease fee is consistent with similar sized lots at the Airport which are 30mtrs x 15mtrs.

The annual Shire rates for a hangar site sized 30mtrs x 15 mtrs are \$980. Mr Wilshire is being charged \$1,960 per annum for Shire rates for his two lots with a combined size of 30mtrs x 12mtrs.

The Officer's recommendation is that Council approve writing off the overdue rates and amalgamating the lots as per the lease agreement.

RECOMMENDATION

That Council approve writing off a rates debt of \$4,296.34 on Hangar 8, 105 Withers Street, Northam in accordance with s6.12(1)(c) of the *Local Government Act 1995*, and combining lot 7 & lot 8 as one lot for the purpose of rates charges.

12.4.7 Change of Ownership for Hangar 31, Northam Airport

Address:	Lot 105 Withers Street, Northam
Owner:	James Rodgers
File Reference:	A15607
Reporting Officer:	Cheryl Greenough Coordinator Governance & Administration
Responsible Officer:	Colin Young Executive Manager Corporate Services
Voting Requirement	Simple Majority

BRIEF

Mr Rodgers who owned Hangar 31 has sold the Hangar to Mr David Beech and requests that Council approve a transfer of the lease agreement.

ATTACHMENTS

Attachment 1: Nil.

BACKGROUND / DETAILS

In June 2017, Mr Rodgers purchased Hangar 31 from Mrs Margaret Symes. The Hangar consisted only of a framework with a derelict plane housed within. Mr Rodgers applied for a building application which was granted and he completed the Hangar.

Mr Rodgers finds that he is unable to continue utilising the Hangar and has sold his interest to Mr David Beech.

CONSIDERATIONS

Strategic Community / Corporate Business Plan
Theme Area 5: Infrastructure & Service Delivery.

Outcome 5.3: To have safe, well-maintained community infrastructure and services to a standard expected of a Regional Centre.

- Improve and encourage utilisation of existing airport facilities and associated air services.

Financial / Resource Implications
Nil.

Legislative Compliance
Section 3.58, Local Government Act 1995, Disposing of Property

- (1) *In this section —
dispose includes to sell, lease, or otherwise dispose of, whether absolutely or not;
property includes the whole or any part of the interest of a local government in property, but does not include money.*
- (2) *Except as stated in this section, a local government can only dispose of property to —
(a) the highest bidder at public auction; or
(b) the person who at public tender called by the local government makes what is, in the opinion of the local government, the most acceptable tender, whether or not it is the highest tender.*
- (3) *A local government can dispose of property other than under subsection (2) if, before agreeing to dispose of the property —
(a) it gives local public notice of the proposed disposition —
(i) describing the property concerned; and
(ii) giving details of the proposed disposition; and
(iii) inviting submissions to be made to the local government before a date to be specified in the notice, being a date not less than 2 weeks after the notice is first given; and
(b) it considers any submissions made to it before the date specified in the notice and, if its decision is made by the council or a committee, the decision and the reasons for it are recorded in the minutes of the meeting at which the decision was made.*

Policy Implications

Policy A8.5(3) Management of Council Property Leases

3.0 Airport Hangar Site Agreement:

- 3.1. The Shire has an expectation that it will receive a rent calculated on the land use or probable use rate at a set rate per square metre determined by the Valuer General; or
- 3.2. No less than market value of vacant land determined by the Valuer General for any lease area or licence.
- 3.3. Lessee or Licensee will be responsible to contribute to the full cost of any previous improvements to the Airport by way of a levy proportioned to the cost of the work by a once-off lease “establishment fee” or “transfer fee”.
- 3.4. All agreements will have a common expiry date and an option to renew shall be limited to no more than five years.
- 3.5. The Lessee or Licensee will be responsible for meeting the full cost of the document preparation, registration and other costs associated with the execution of the agreement.
- 3.6. All improvements, repairs and maintenance to the “Demised Premises” are the sole responsibility of the Lessee or Licensee.

- 3.7. The Lessee or Licensee will be responsible for building and contents and also hold current public liability insurance and worker compensation (if applicable) to the value stipulated in the agreement.

Stakeholder Engagement / Consultation

Advertising of the disposal of property will be undertaken in the West Australian newspaper and the Avon Valley Advocate newspaper for a period of two weeks.

Risk Implications

Nil.

OFFICER'S COMMENT

At the Ordinary Council meeting 21 June 2017, Council approved the transfer of Mrs Symes' lease to Mr James Rodgers and Mr Peter Newnes. In mid-July after the required 2 weeks consultation period ended, staff requested a new lease be drawn up for the above clients.

A new lease will need to be drawn up for Mr Beech. The lease term will expire in June 2030 under the same general conditions as previous leases. As such Mr Beech would be responsible for all costs as detailed in the Shire of Northam Policy plus Shire rates, any connection to utilities such as water, telephone, gas and electricity.

RECOMMENDATION

That Council:

1. Instruct the CEO to advertise the disposal of the property for a two week consultation period in accordance with *section 3.58 of the Local Government Act 1995*.
2. Authorise the transfer of lease for Hangar 31, Lot 105 Withers Street Northam to Mr David Beech subject to the following conditions and in accordance with Shire of Northam Policy A8.5:
 - Expiry date of 2030;
 - A lease rental of \$1,236.80 with CPI increases annually;

12.4.8 Aboriginal Environmental and Interpretative Centre Solar System

Address:	Lot 2 Minson Avenue, Northam
Owner:	Shire of Northam
File Reference:	2.4.2.3
Reporting Officer:	Leasa Osborne Purchasing Officer
Responsible Officer:	Colin Young Executive Manager Corporate Services
Voting Requirement	Absolute Majority

BRIEF

For the Council to consider buying outright a solar system for the Aboriginal Environmental and Interpretative Centre.

ATTACHMENTS

Attachment 1: **Ironbark's report** (provided as a separate confidential attachment to this agenda/minutes).

BACKGROUND / DETAILS

The Shire of Northam called for quotes relating to solar energy for some of the Shire's buildings. Three solar companies answered the request and provided information regarding solar systems on Shire owned buildings.

One of those buildings included the Aboriginal Environmental and Interpretive Centre (AEIC). The plans for the AEIC building layout diagrams completed by Iredale Pedersen Hook architects, were submitted to three companies with the original request to submit a proposal/quote for a Power Purchase Agreement (PPA) for a 10kw system. We received three proposals which included two PPA options and two Outright Purchase Options.

External Consultant Company Ironbark were contacted to assess the three proposals and submit a report with their expert recommendation as to which option would be most viable for Council. Ironbark's recommendation was that it would be most viable to purchase a solar system outright.

After receiving Ironbark's recommendation we contacted the three companies who previously submitted a proposal/quote and advised them that after assessment of all proposal/quotes it was most viable for Council to purchase a 10kw system outright, and gave them the option to resubmit a current proposal/quote for an outright purchase. Two of the previous companies accepted the offer to resubmit & one declined to submit for an

outright purchase. We then contacted a Local Solar Company (CDA) enquiring if they would be interested in submitting a proposal/quote and forwarded through all plans and details previously provided to the other three companies.

External Consultant Company Ironbark was then contacted again to assess the three new proposals for an outright purchase and submit a report with their expert recommendation as to which option would be most viable for Council.

After receiving Ironbark's report we went back to the CDA and Solgen to see if there was any possibility of reducing the price to be competitive with the other company that had quoted. The Local Supplier came back to us with a reduction of \$2,900.00 off their original proposal/quote, and Solgen came back to us with a reduction of \$585.00, so the prices for these two companies detailed in Ironbark's report will differ from the presented amount within this report.

After applying the Shire of Northam Local Price Preference Policy the Local Company's proposal/quote was reduced by 10% making it the preferred option.

The full report from Ironbark is supplied as a separate confidential document.

CONSIDERATIONS

Strategic Community / Corporate Business Plan

Theme Area 1: Economic Growth

Outcome 1.1: The Shire of Northam is an attractive investment destination for a variety of economic sectors.

- Ensure the Shire of Northam is a welcoming and easy place for quality investment to occur; and
- Pursue a range of developments in sectors including retirement living, renewable energy, agribusiness, innovation, logistics and aviation.

Financial / Resource Implications

As this was not included in the 2017/18 budget it is recommended that it be funded by a transfer from the Council building & amenities reserve, of which the projected balance as of the 30th June 2018 is presented below;

Council Buildings & Amenities Reserve		
Current Budget as of 30/06/2018	Proposed transfer	Projected Balance as of 30/06/2018
\$350,114.00	\$12,015.00	\$335,182.32

Legislative Compliance

Local Government Act 1995 – s3.57 Tenders

Local Government (Functions & General) Regulations 2000 - Part 4A
Local Government (Administration) Amendment Regulations 2000 – s29

Policy Implications

Policy F 4.2 – Purchasing and Tendering Policy

Policy F 4.4 – Local Price Preference

Stakeholder Engagement / Consultation

Not applicable

Risk Implications

There is a risk that new Solar System technology will make the purchased system obsolete.

OFFICER'S COMMENT

A total of three quotes were submitted, all submissions were based on the most viable option of purchasing the system outright. The following evaluation was carried out by Ironbark, noting that the CDA prices were reduced after the evaluation;

	Weighting	CDA Air & Solar	CDA Air & Solar	Solar E	Solgen
Quality	30%	85%	80%	85%	90%
Company Experience	15%	85%	85%	90%	90%
Methodology	10%	80%	80%	95%	90%
Cost	45%	80%	80%	90%	80%
Weighted Average		82%	81%	89%	86%

The following is the actual quoted prices from the suppliers

Company	Amount
CDA Air and Solar	\$12,015
Solgen	\$12,972
Solar E	\$11,448

After having the submissions evaluated by Ironbark and applying our Local Price Preference Policy the CDA option is recommended.

The estimated payback period is three (3) years.

RECOMMENDATION

That Council

1. Authorises the CEO to engage CDA Air & Solar for \$12,015.00 to supply a Solar System for the AEIC
2. Adopts the transfer of \$12,015.00 from the Councils Building & Amenities reserve if required at June 30 2018.

ABOSLUTE MAJORITY OF 6 REQUIRED

12.5 COMMUNITY SERVICES

12.5.1 Application for Fee Waiver - Pipeline Challenge

Address:	Northam Recreation Centre
Owner:	Shire of Northam
File Reference:	1.3.16.4
Reporting Officer:	Ross Rayson Executive Manager Community Services
Responsible Officer:	Ross Rayson Executive Manager Community Services
Voting Requirement	Simple Majority

BRIEF

For Council to consider a waiver of fees for the use of Northam Recreation Centre and Jubilee oval for the Pipeline Challenge, an annual charity mountain bike event conducted by Youth Futures.

ATTACHMENTS

Attachment 1: Letter requesting Fee Waiver.

BACKGROUND / DETAILS

The Pipeline Challenge is an annual charity mountain biking event conducted by Youth Futures, which fund raises for homeless and disadvantaged young people.

The ride follows the golden pipeline from Kalgoorlie to Perth.

The organisers, Youth Futures, are requesting Council waive fees as below:

Description	Start Time	End Time	No of Units	Comments	Start Date	Finish Date	Fee Charged
Event Application Fee				Pipeline Challenge	08/05/2018	09/05/2017	\$154.00
HENRY ST OVAL (including lights)	11:00	10:00		Pipeline Challenge	08/05/2018	09/05/2017	\$610.00

RECREATION CENTRE Hospitality Room + Kitchen	11:00	10.00		Pipeline Challenge	08/05/2018	09/05/2017	\$ 710.00
						total	\$1474.00

The riders are predicted to arrive in Northam on 8th May for an overnight stop before continuing to the finish of the ride on the 9th May.

Youth Futures are aiming to raise in excess of \$150,000 from this year's event.

Council resolved to support this event in 2017 at its Ordinary Council meeting held on 17th May 2017 by providing a fee waiver for the hire and event application fees associated.

CONSIDERATIONS

Strategic Community / Corporate Business Plan

Theme Area 1: Economic Growth.

Outcome 1.4: A robust tourism industry which contributes to the economic development of the Shire of Northam and optimises Northam's role as a hub for tourists to the region.

Financial / Resource Implications

The fees that Council resolve to waive will represent foregone income. This will be to a maximum of \$1474.00

Legislative Compliance

Local Government Act 1995, Section 6.12 - Power to defer, grant discounts, waive or write off debts.

Policy Implications

Nil.

Stakeholder Engagement / Consultation

Nil.

Risk Implications

The risk of not waiving the fees is that any costs passed onto the event reduces the amount of potential funds raised.

OFFICER'S COMMENT

This event is becoming a regular event, with the numbers of participants increasing each time. Whilst there is not likely to be a great return on investment

for the Shire in waiving of fees, there will still be some exposure from a tourism point of view, and some economic benefit from hosting this event for one day.

The attached letter from the applicant has requested a fee waiver of \$1,340.00. It should be noted that this amount was based on the initial booking of facilities. Youth Future have now confirmed their booking requirements, resulting in the amended total of \$1,474.00 including GST.

RECOMMENDATION

That Council waive the following fees as a donation to Youth Futures to assist with the conduct of the 2018 Pipeline Challenge:

- a. Hire fees for Henry St Oval including lights (\$610.00 incl GST)
- b. Hire fees for Hospitality Room, including kitchen (\$710.00 incl GST)
- c. Event application fee (\$154.00 incl GST)

Attachment 1



Phone: (08) 9300 2877
Fax: (08) 9300 1565
E: youthfutureswa@youthfutureswa.com.au
W: www.youthfutureswa.com.au

ABN 11 124 211 565

Mr Jason Whitaker
Chief Executive Officer
Shire of Northam
395 Fitzgerald Street
Northam WA 6401

Dear Mr Whitaker,

Following on from our conversation with Brendon Rutter-Community Events Officer, we are writing to seek the waiving of \$1,340 in event fees and charges for Youth Futures to utilise the Northam Recreation Centre and Oval for the Pipeline Challenge, a charity mountain biking event that hopes to raise over \$150,000 for young people experiencing homelessness and disadvantage.

Established in 1988, Youth Futures provides professional support, accommodation and alternative education services to thousands of at-risk young people each year. The funds raised from the Pipeline Challenge will provide our organisation with financial security and the opportunity to expand our services.

Starting from Kalgoorlie on Saturday 5th May 2018, the Pipeline Challenge will trace the iconic Goldfields Pipeline through Coolgardie, Southern Cross, Merredin and Northam, finishing in Mundaring on Wednesday 9th May 2018.

Not only will the Pipeline Challenge be raising vital funds for disadvantaged and at-risk young people, but it will provide a great opportunity to increase the profile of Northam and its surrounds to people who may not otherwise see what the region has to offer. We are also happy to acknowledge the Shire's support on our websites and social media.

We are very excited at the prospect of working with the Shire of Northam again and we thank you for taking the time to consider our request. Please note we are also happy to provide any additional information that will aid the Shire in making an informed decision.

Kind regards,



Mark Waite
Chief Executive Officer

Joondalup Lotteries House
Suite 1
70 Davidson Terrace
Joondalup WA 6027

12.5.2 Application for Fee Reduction – Northam PCYC

Address:	Northam and Wundowie Swimming Pools
Owner:	Shire of Northam
File Reference:	1.3.16.4
Reporting Officer:	Milton Brooks Manager Recreation Services
Responsible Officer:	Ross Rayson Executive Manager Community Services
Voting Requirement	Simple Majority

BRIEF

For Council to consider a request from Northam PCYC for a 70% fee discount for use of Meeting Room 3 at the Northam Recreation Centre for the conduct of their Stepping Stones alternative education program during the refurbishment of the their premises during term 4 of 2017

ATTACHMENTS

Attachment 1: Letter from Northam PCYC requesting fee reduction.

BACKGROUND / DETAILS

The Northam Police & Community Youth Centre (Northam PCYC) is a not for profit organisation that has been operating in Northam and surrounding areas for over 60 years. Their building at 133 Wellington St is currently being refurbished to enable them to continue to deliver services to youth and other community groups within the Shire of Northam.

To enable PCYC to continue their Stepping Stones program during refurbishment, several venues in Northam were sourced as potential options. There was found to be a lack of suitable options for the group to work from, and as such the Northam PCYC booked Meeting Room 3 at the Northam Recreation Centre from 9th October to 14th December 2017. With the daily community rate for a meeting room at the Northam Recreation Centre set at \$210, the total owing for the 58 days hire is \$12,180. At the time of booking, the Northam PCYC representatives made note their intention to seek a discounted fee, due to the community service provision for which the room would be used. It should be noted that there has been no request from PCYC for free use of this facility.

At the Ordinary Council meeting of 18th October 2017, Council considered the following:

MOTION / COUNCIL DECISION

Minute No: C.3165

Moved: Cr Tinetti
Seconded: Cr Antonio

That Council waive the fee for hire of the Lesser Hall for PCYC to use during upgrades to their premises. The lease period will be from 9th October to 15th December 2017.

CARRIED 10/0

The monetary value for the fee waiver for the Lesser Hall as resolved above, totals \$1,150.

MOTION

Moved: Cr Hughes
Seconded: Cr Tinetti

That Council charge the PCYC a \$3,000 fee for the hire of meeting room three at the Northam Recreation Centre in lieu of the standard booking fees.

LOST 5/5

BY PRESIDENT'S CASTING VOTE

Subsequently, Northam PCYC has submitted a request for a 70% discount on their fee. Their letter references a 70% discount that is applied to not for profit groups working with youth. Whilst not specifically referenced, it is believed that this is in direct reference to Council resolution that provided the Northam Swimming Club a discount for their use of the Northam pool for their training, time trials and carnivals as per the below recommendation.

RECOMMENDATION

Minute No: C.3159

Moved: Cr Hughes
Seconded: Cr Rumjantsev

That Council:

1. **Apply a seasonal fee of \$1,200.00 for the Northam Swim Club's use of the Northam Pool for the 2017/18 season; and**
2. **Apply the same fee reduction to the Wundowie Swim Club for their use of the Wundowie Pool.**

CONSIDERATIONS

Strategic Community / Corporate Business Plan

Theme Area 2: Community Wellbeing.

Outcome 2.1: People in the Shire of Northam feel that their community is caring and inclusive.

Objective: Improved facilities and activities for youth are available within the Shire.

Financial / Resource Implications

The value of the facility hire the Northam PCYC are liable for is \$12,180. They are requesting a discount of \$8,526 leaving \$3,654 owing.

Legislative Compliance

Local Government Act 1995, Part 6, Division 4, Section 6.12

6.12. Power to defer, grant discounts, waive or write off debts

(1) Subject to subsection (2) and any other written law, a local government may —

(a) when adopting the annual budget, grant a discount or other incentive for the early payment of any amount of money; or*

(b) waive or grant concessions in relation to any amount of money; or

(c) write off any amount of money, which is owed to the local government.

**Absolute majority required.*

(2) Subsection (1) (a) and (b) do not apply to an amount of money owing in respect of rates and service charges.

(3) The grant of a concession under subsection (1) (b) may be subject to any conditions determined by the local government.

Policy Implications

Nil.

Stakeholder Engagement / Consultation

Due to the close working relationship between the Northam PCYC and Shire Officers, the Northam PCYC have been consulted as to the process and the progress of enquiries throughout.

Risk Implications

The risk associated with not reducing the hire fee would be increased financial hardships on the Northam PCYC in delivering their community service programs. A grant funded organisation, their capacity to deliver their programs is directly inversely proportionally related to their expenditure.

The risk associated with waiving the fee is the reduced income of the Northam Recreation Centre.

OFFICER'S COMMENT

As a not-for-profit group supporting the community, the Northam PCYC support many Shire of Northam initiatives such as the Inclusion program during the school holidays and more recently the Night Hoops program for at risk youth. Consequently they provide a service to the Shire of Northam which assists the Shire to achieve its theme of a cohesive community with access to quality services; specifically the outcome that the people in the Shire of Northam feel that their community is caring and inclusive and the objective of improved facilities and activities for youth be available.

In the October meeting it was questioned as to the impact the Northam PCYC booking had on existing and potential users of the facility. While Shire staff were required to reorganise some regular bookings in order to accommodate the PCYC's Stepping Stones program, no user group has been turned away or adversely effected by PCYC's use of the room.

The 70% discount letter refers to the manner in which the seasonal fee applied to junior sporting groups' use of Shire of Northam facilities, as it compares to the casual hire fee that would be incurred should the junior sporting group hire each facility individually. The reduced rate is representative of a bulk booking and the Shire support of junior sporting organisations in their provision of sporting pursuits to juniors in Northam. As such, it is felt that it is not applicable to Northam PCYC.

The casual fee for the use of Shire facilities is however set with one-off usage in mind. For extended periods, a lease arrangement is entered into, such as the Hockey and Cricket's utilisation of Bert Hawke pavilion, and the Swimming Club's peppercorn lease on their clubrooms.

With regards to the request from PCYC, Council have a number of options:

1. Determine no discount is applicable and have the full \$12,180 charged;
2. Agree to the 70% discount on total usage resulting in a total fee of \$3,654;
or
3. Apply an alternate discount to the amount requested.

It is recommended that council agree to discounted usage due to:

1. Northam PCYC's support of the Shire's theme of a cohesive community;
2. The intention for the fee for use of the room being for casual one-off bookings;
3. With the PCYC not expecting or requesting free use; and

4. The last minute nature of the booking meaning the PCYC were not able to enter into a formal lease agreement which would have reduced their fee.

RECOMMENDATION

That Council apply a 70% discount to the fees incurred for the Northam **PCYC's hire of the Meeting Room at the Northam Recreation Centre**, resulting in a hire fee of \$3,654.



21 November 2017

CEO
Shire of Northam
P O Box 613
NORTHAM WA 6401

Att: Mr Jason Whiteaker

Dear Mr Whiteaker

Re: Hire of Meeting Room 3 at the Recreation Centre

Northam Police & Community Youth Centre (PCYC) is a not for profit organisation that has been operating in Northam and surrounding areas for over 60 years. Our building at 133 Wellington St is currently being refurbished to enable us to continue to deliver services to youth and other community groups. Our refurbishment is long overdue as part of the building will be 60 years old in 2018.

To enable us to continue our Stepping Stones alternative education program for disengaged youth we required alternative premises for Term 4 2017. We explored all available options in the CBD of Northam, but unfortunately we were unable to find suitable space. Our funding for this program does not include funds for rental of space. The Recreation Centre offered us the use of Meeting Room 3, which we accepted on the understanding we would receive a concessional rate. We have booked Meeting Room 3 from 9th October to 14th December 2017. The full charge for this period of time is \$12,180 inc. GST. We would like to request a reduction of 70%, in line with previous council decisions for other not for profit community groups working with youth. This would be a total of \$3,654.00 inc. GST.

I would appreciate the opportunity to speak at the Council Forum in December to provide a better understanding of all that PCYC offers Northam.

Yours sincerely

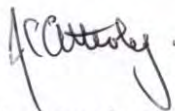

Jane Atterby
Centre Manager - Northam

12.5.3 Naming of Aboriginal & Environmental Interpretive Centre

Address:	Grey Street/Minson Avenue, Northam
Owner:	Shire of Northam
File Reference:	1.3.13.5
Reporting Officer:	Michelle Blackhurst Community Development Officer
Responsible Officer:	Ross Rayson Executive Manager Community Services
Voting Requirement	Simple Majority

BRIEF

The purpose of this report is to seek Council's endorsement of the recommended official name of the Aboriginal and Environmental Interpretive Centre (AEIC), as recommended by the Aboriginal Advisory Committee.

ATTACHMENTS

Nil.

BACKGROUND / DETAILS

The AEIC is now under construction along the Avon River, adjacent to the existing Northam Visitors Centre. The design features a large interpretive space, freeform space suitable for exhibitions, workshop space, a retail space and offices.

A strategy of the Northam Aboriginal and Environmental Interpretive Centre Marketing Plan is to determine an appropriate Nyoongar name for the Centre, which reflects both the Aboriginal cultural and environmental elements.

The official name of the Centre has been discussed by the Aboriginal Advisory Committee at length. At its meeting held on Tuesday, 14 November 2017, the Committee finalised their decision and recommend to Council that the Centre be named '**Maali Bilya Koort Boodja**', which translated to English means Swan River Heart Lands. Further to this, the Committee has recommended that an English line of text should accompany the Nyoongar name – '**Centre for Nyoongar Culture and Environmental Knowledge**'.

CONSIDERATIONS

Strategic Community / Corporate Business Plan
Theme Area 4: Environment & Culture.

Outcome 4.2: The Shire of Northam honours, and is recognised for, its unique heritage and cultural identity.

Financial / Resource Implications
N/A.

Legislative Compliance
N/A.

Policy Implications
N/A.

Stakeholder Engagement / Consultation

The official name of the Centre has been discussed by the Aboriginal Advisory Committee at length. At its meeting held on Tuesday, 14 November 2017, the Committee finalised their decision for recommendation.

Risk Implications
N/A.

OFFICER'S COMMENT

The recommended name Maali Bilya Koort Boodja, translated to English means Swan River Heart Lands. This name was selected for the following reasons:

1. Maali (Swan) – This has reference specifically to the black swan which is of spiritual significance in the traditional histories of many of the Aboriginal peoples.
2. Bilya (River) – The Aboriginal peoples have a long and strong connection to the river. The river is also a local environmental focus.
3. Koort Boodja (Heart Lands) - The group wanted to express through the name that their country is something that they have a strong connection with. The land is in their hearts. This also explains the relationship between the Aboriginal culture and environmental knowledge.

The group felt it was important to include the English line of text 'Centre for Nyoongar Culture and Environmental Knowledge' to clearly illustrate to tourists what the theme of the Centre is. This also clearly indicates that the AEIC has two interpretive themes of 'Nyoongar Culture' and 'Environment'.

RECOMMENDATION

That Council endorse the name 'Maali Bilya Koort Boodja – Centre for Nyoongar Cultural and Environmental Knowledge' as the official name of the Aboriginal and Environmental Interpretive Centre.

12.5.4 Tender 5 of 2017 – Architectural/Building Design Services for the Northam Aquatic Centre

Address:	Peel Terrace, Northam
Owner:	Shire of Northam
File Reference:	1.3.8.8
Reporting Officer:	Ross Rayson Executive Manager Community Services
Responsible Officer:	Ross Rayson Executive Manager Community Services
Voting Requirement	Absolute Majority

BRIEF

For the Council to consider tenders received in response to the Request for Tender 5 of 2017 – Architectural /Building Design Services for the Northam Aquatic Centre. This report provides details of the tenders received to allow Council to appoint a successful tenderer to design the Northam Aquatic Centre.

ATTACHMENTS

Attachment 1: Tender Evaluation Report – CONFIDENTIAL (To be provided later)

Attachment 2:

BACKGROUND / DETAILS

At the Ordinary Council Meeting of 16 August 2017, Council resolved the following:

RECOMMENDATION / COUNCIL DECISION

Minute No: C.3116

Moved: Cr Hughes
Seconded: Cr Williams

That Council;

1. Notes the outcome of the funding application via the Building Better Regions Fund of \$3,200,000.
2. Authorises the Chief Executive Officer to commence the development of an outdoor heated 50m swimming pool and associated leisure

facilities at the Northam Recreation Centre Precinct, based on concept drawings and costings previously endorsed.

3. Confirms the total budget for construction of the project is \$8.0m
4. Amends the 2017/18 budget for the 50m Swimming Pool Construction from 3.8m to 8.0M.
5. Amends the funding as such;
 - Increase the proposed loan from \$1.0m to \$2.3m
 - Increase the budgeted transfer from the Recreation and Community Facilities Reserve from \$500,000 to \$1.0m
 - Remove the WDC Grant for \$300,000
 - Remove the Other Grant for \$500,000
 - Include the Building Better Regions Fund Grant of \$3.2m

CARRIED 8/0

Following the resolution, detailed plans were developed to allow the Architectural design services for the Aquatic facility to be tendered.

Tender 5 of 2017 for Architectural Design Services for the Aquatic Centre was advertised on Saturday 7th October 2017. The tender process was conducted by WALGA through the online tender portal. As part of the tender process, an onsite meeting for prospective tenderers was held on 17th October 2017, and tender submissions closed on 31st October 2017.

The evaluation panel consisted of the CEO, Executive Manager Community Services, Manager Recreation Services, and Brandon Pike-WALGA.

A total of 15 tender submissions were received and each was evaluated in accordance with the tender documents and the following qualitative criteria was used in arriving at the final report-

Related Experience – 30%
Project Consideration – 35%
Project Methodology – 35%

Following the qualitative evaluation, pricing was ranked from least expensive and a Relative Value for Money assessment undertaken.

A full report on the procurement process and tender evaluation is provided in Confidential-Attachment 1

CONSIDERATIONS

Strategic Community / Corporate Business Plan

Theme 2: Community Wellbeing.

Outcome 2.2: There are a variety of recreation and leisure activities available for all ages, across the Shire of Northam.

Financial / Resource Implications

It is estimated that the Northam Aquatic Centre will cost \$8.0m. As previously outlined, external funding of \$4.7m has been confirmed for this project, consisting of:

- Community Sport and Recreation Facilities Fund: \$1.5m
- Building Better Regions Fund: \$3.2m

Additionally the tender requested a submission for the provision of project superintendent services for the construction phase of the project. This was an optional component. At this point no firm decision has been made on the requirement for such services, however the recommendation is to provide authority for the Chief Executive Officer to engage these services if deemed necessary. It is considered more likely than not that these services would be utilised by the Shire of Northam.

Legislative Compliance

Section 3.57 of the Local Government Act 1995 requires a local government is required to invite tenders before it enters into a contract of a prescribed kind under which another person is to supply goods and services".

The Local Government (Functions & General) Regulations 1996 prescribe the manner in which Tenders are to be called and assessed.

Policy Implications

Policy F 4.2 – Purchasing and Tendering Policy.

Stakeholder Engagement / Consultation

Council undertook community consultation in regard to the development of the Northam Aquatic Centre to determine location and community expectations of the facility.

Council engaged WALGA procurement services to manage the tender process on its behalf.

Risk Implications

The following is based on the original risk assessment undertaken for the project.

RISK ITEM DESCRIPTION	IMPACT	PROBABILITY OCCURANCE WITHOUT MITIGATION					EXISTING CONTROLS	ADDITIONAL CONTROLS
		A. Almost Certain	B. Likely	C. Possible	D. Unlikely	E. Rare		
1. Financial Inability to secure external funding due to poor funding applications	↓	A. Almost Certain	B. Likely	C. Possible	D. Unlikely	E. Rare	<ul style="list-style-type: none"> Internal reviews by Exec Management 	<ul style="list-style-type: none"> Use of external consultant
	5. EXTREME				✓			
	4. MAJOR							
	3. MEDIUM							
	2. MINOR							
	1. INSIGNIFICANT							
2. Financial Inability to secure external funding due no funding opportunities	↓	A. Almost Certain	B. Likely	C. Possible	D. Unlikely	E. Rare	<ul style="list-style-type: none"> Internal reviews by Exec Management 	<ul style="list-style-type: none"> Use of external consultant
	5. EXTREME			✓				
	4. MAJOR							
	3. MEDIUM							
	2. MINOR							
	1. INSIGNIFICANT							
3. Financial Inability to afford ongoing operations due to decision made on unsuitable option	↓	A. Almost Certain	B. Likely	C. Possible	D. Unlikely	E. Rare	<ul style="list-style-type: none"> Feasibility report provided to Council 	<ul style="list-style-type: none"> External review
	5. EXTREME							
	4. MAJOR			✓				
	3. MEDIUM							
	2. MINOR							
	1. INSIGNIFICANT							
4. Financial Inability to afford ongoing operations due to financial modelling inaccurate	↓	A. Almost Certain	B. Likely	C. Possible	D. Unlikely	E. Rare	<ul style="list-style-type: none"> Modelling undertaken internally and compared with other like facilities 	<ul style="list-style-type: none"> External review Undertake sensitivity analysis
	5. EXTREME							
	4. MAJOR			✓				
	3. MEDIUM							
	2. MINOR							
	1. INSIGNIFICANT							
5. Financial Increase in cost of borrowing due to Reserve Bank increases Interest rate	↓	A. Almost Certain	B. Likely	C. Possible	D. Unlikely	E. Rare		<ul style="list-style-type: none"> Fix interest rates for term of loan
	5. EXTREME							
	4. MAJOR							
	3. MEDIUM			✓				
	2. MINOR							
	1. INSIGNIFICANT							

OFFICER'S COMMENT



A full report on the procurement process and outcomes is provided as a separate document.

RECOMMENDATION

That Council appoints Donovan Payne Architects to;

- 1. Provide Architectural/Design Services to the Shire of Northam for the development of the Northam Aquatic Centre at a cost of \$275,000 (ex GST).**
- 2. Provide project Superintendent Services for the construction of the Northam Aquatic Centre at a cost of up to \$110,000 (ex GST), if deemed required by the Chief Executive Officer.**

13. MATTERS BEHIND CLOSED DOORS

13.2 CHIEF EXECUTIVE OFFICER REVIEW COMMITTEE MEETING HELD ON 30TH NOVEMBER 2017

Note: The minutes from the meeting have been provided to Council as a separate confidential attachment to this agenda/minutes.

Receipt of Minutes:

RECOMMENDATION

That Council receive the minutes from the Chief Executive Officer Review Committee meeting held on 30th November 2017.

Adoption of Recommendations:

RECOMMENDATION

That Council:

1. **Endorse the Chief Executive Officer's performance indicators for the 2017/18 review period as listed in Attachment 1.**
2. Notes the Determination of the Salaries and Allowances Tribunal dated 11 April 2017 and approves a 2.5% increase to the Chief **Executive Officer's annual base salary of \$233,139 per annum (total reward package of \$269,438 per annum)**, effective from 2 September 2017; and
3. Request the next review of remuneration be completed by 2 September 2018, in accordance with the contract of employment between Council and Mr Whiteaker.

14. MOTIONS OF WHICH PREVIOUS NOTICE HAS BEEN GIVEN

Nil.

15. URGENT BUSINESS APPROVED BY PERSON PRESIDING OR BY DECISION

16. DECLARATION OF CLOSURE